



TABLE OF CONTENTS

ET10K INSTRUCTION MANUAL

SECTION 100 DESCRIPTION & SPECIFICATIONS

17450	INSTALLATION DIMENSIONS - ET10K(X)
I17390	17390 BASE MOUNTING DIMENSIONS
19529	CAPACITY CHART - ET10K(X)
16938	TYPICAL REINFORCEMENT FOR MOUNTING CRANE ON TOP OF SERVICE BODY
S17340	INSTALLATION DRAWING - 17340 MOUNTING PEDESTAL
I17340	INSTALLATION DRAWING - 17340 MOUNTING PEDESTAL
▲ 22687	INSTALLATION DRAWING - 18500-P MANUAL OUTRIGGER
▲ 22686	INSTALLATION DRAWING - 18500-CD MANUAL OUTRIGGER
13509	INSTALLATION DIMENSIONS - 13500 MANUAL OUTRIGGER SIDE BRACKET
I23961	INSTALLATION DIMENSIONS - 23961 MANUAL OUTRIGGER SIDE BRACKET
13510	INSTALLATION DIMENSIONS - 11822 MANUAL OUTRIGGER FOLD AWAY TYPE
I23960	INSTALLATION DIMENSIONS - 23960 MANUAL OUTRIGGER FOLD AWAY TYPE

SECTION 150 SAFETY

15394	VEHICLE & CRANE ELECTRICAL HAZARD INFORMATION
850711	SAFETY & HAZARDS - GENERAL

SECTION 200 INSTALLATION

711105	CABLE & BATTERY REQUIREMENTS - ET AND HT CRANES
15660	BATTERY CABLE INSTALLATION DRAWING
900530a	ET10K(X) OPERATION & MAINTENANCE INSTRUCTIONS - PAGE 1 OF 4
900530b	ET10K(X) OPERATION & MAINTENANCE INSTRUCTIONS - PAGE 2 OF 4
900530c	ET10K(X) OPERATION & MAINTENANCE INSTRUCTIONS - PAGE 3 OF 4
900530d	ET10K(X) OPERATION & MAINTENANCE INSTRUCTIONS - PAGE 4 OF 4
711006	WIRE ROPE SPECIFICATIONS
20415A	RADIO INSTALLATION / OPERATION INSTRUCTIONS - RADIO REMOTE (PAGE 1 OF 2)
20415B	RADIO INSTALLATION / OPERATION INSTRUCTIONS - RADIO REMOTE (PAGE 1 OF 2)
20416	RADIO OPERATION INSTRUCTIONS
20076	ADJUSTABLE BOOM REST

SECTION 300 MAINTENANCE & SERVICE

800306	MINIMUM VOLTAGE TEST
--------	----------------------

SECTION 400 REPLACEMENT PARTS

19363	ET10K REPLACEMENT PARTS DRAWING
19289	ET10K REPLACEMENT PARTS LIST
19301	ET10K REPLACEMENT FASTENER LIST
20197-3	REPLACEMENT PARTS - ANTI-TWO-BLOCK
20592	ELECTRICAL SYSTEM SCHEMATIC - ET10K
20593	ELECTRICAL SYSTEM SCHEMATIC - ET10K WITH ANTI-TWO-BLOCK
17935	HYDRAULIC SYSTEM SCHEMATIC - ET10K
19791	REPLACEMENT PARTS - 3 FUNCTION CRANES
20947	RADIO REMOTE REPLACEMENT PARTS DRAWING
16770	16770 SWIVEL TERMINAL ASSEMBLY REPLACEMENT PARTS
20493	17211 WINCH POWER UNIT REPLACEMENT PARTS DRAWING
20494	17211 WINCH POWER UNIT REPLACEMENT PARTS LIST

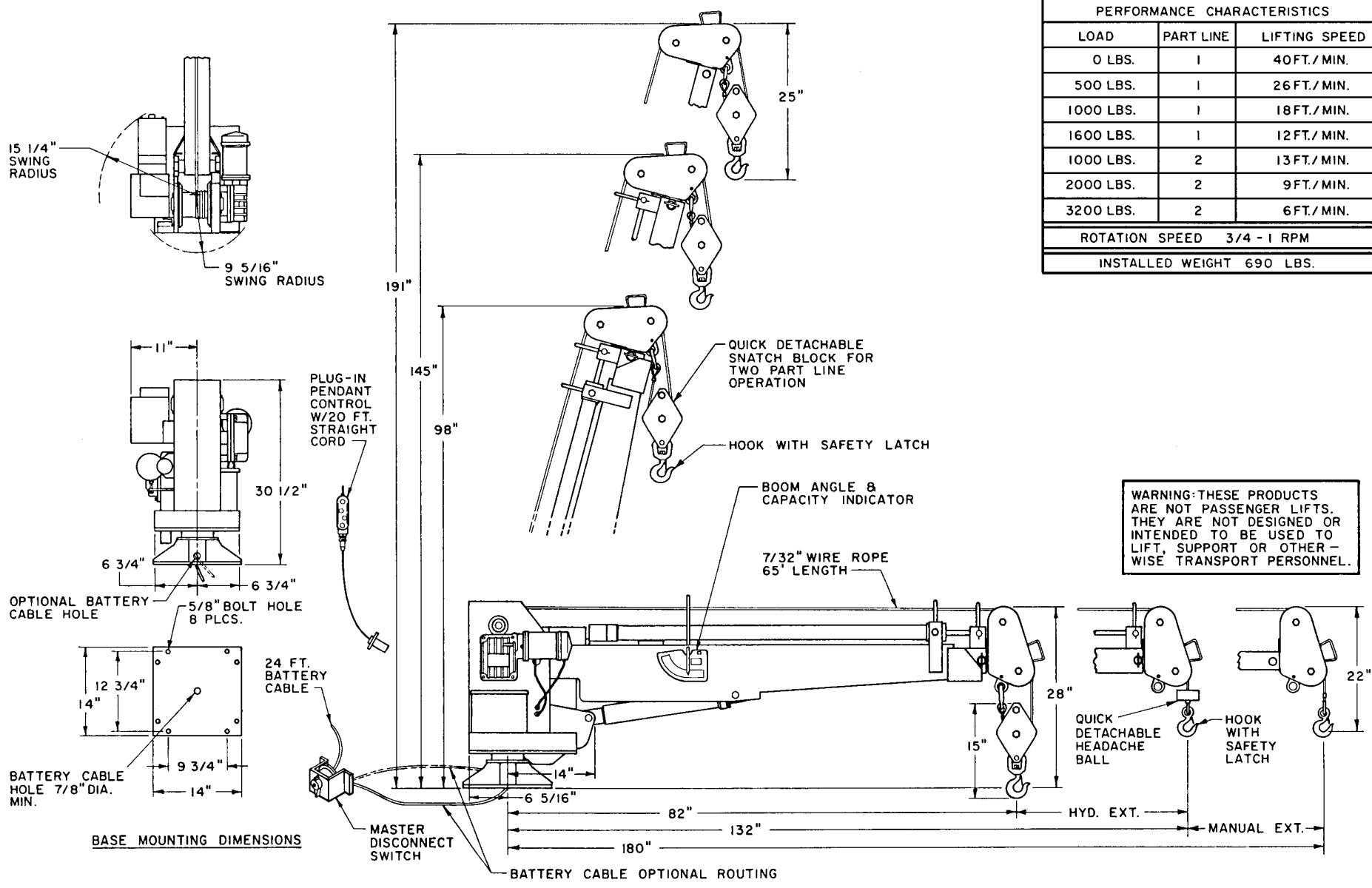

TABLE OF CONTENTS

ET10K INSTRUCTION MANUAL

SECTION 400 REPLACEMENT PARTS

I16100	16100 SERIES POWER UNIT REPLACEMENT PARTS DRAWING
811016	16100 SERIES POWER UNIT REPLACEMENT PARTS LIST
I17930	17930-1 HYDRAULIC POWER UNIT REPLACEMENT PARTS
17451	17260-1 HYDRAULIC POWER UNIT REPLACEMENT PARTS DRAWING
900220	17260-1 HYDRAULIC POWER UNIT REPLACEMENT PARTS LIST
17257-3	17255/17256 ELEVATION CYLINDER REPLACEMENT PARTS DRAWING
931130	17255/17256 ELEVATION CYLINDER REPLACEMENT PARTS LIST
▲ 17824	FIELD SERVICE LABEL KIT
22688	REPLACEMENT PARTS - 18500-P MANUAL OUTRIGGER
22689	REPLACEMENT PARTS - 18500-CD MANUAL OUTRIGGER



PERFORMANCE CHARACTERISTICS		
LOAD	PART LINE	LIFTING SPEED
0 LBS.	1	40 FT./MIN.
500 LBS.	1	26 FT./MIN.
1000 LBS.	1	18 FT./MIN.
1600 LBS.	1	12 FT./MIN.
1000 LBS.	2	13 FT./MIN.
2000 LBS.	2	9 FT./MIN.
3200 LBS.	2	6 FT./MIN.
ROTATION SPEED		3/4 - 1 RPM
INSTALLED WEIGHT 690 LBS.		

WARNING: THESE PRODUCTS ARE NOT PASSENGER LIFTS. THEY ARE NOT DESIGNED OR INTENDED TO BE USED TO LIFT, SUPPORT OR OTHERWISE TRANSPORT PERSONNEL.

VENTURO MANUFACTURING, INC.
CINCINNATI, OHIO

TITLE
INSTALLATION DRAWING

DATE
6-19-98A

SECTION
C100

ET10K(X), W/ 7 - 15 FT BOOM

SUPERCEDES
1-12-90

17450



MOUNTING HOLE TEMPLATE

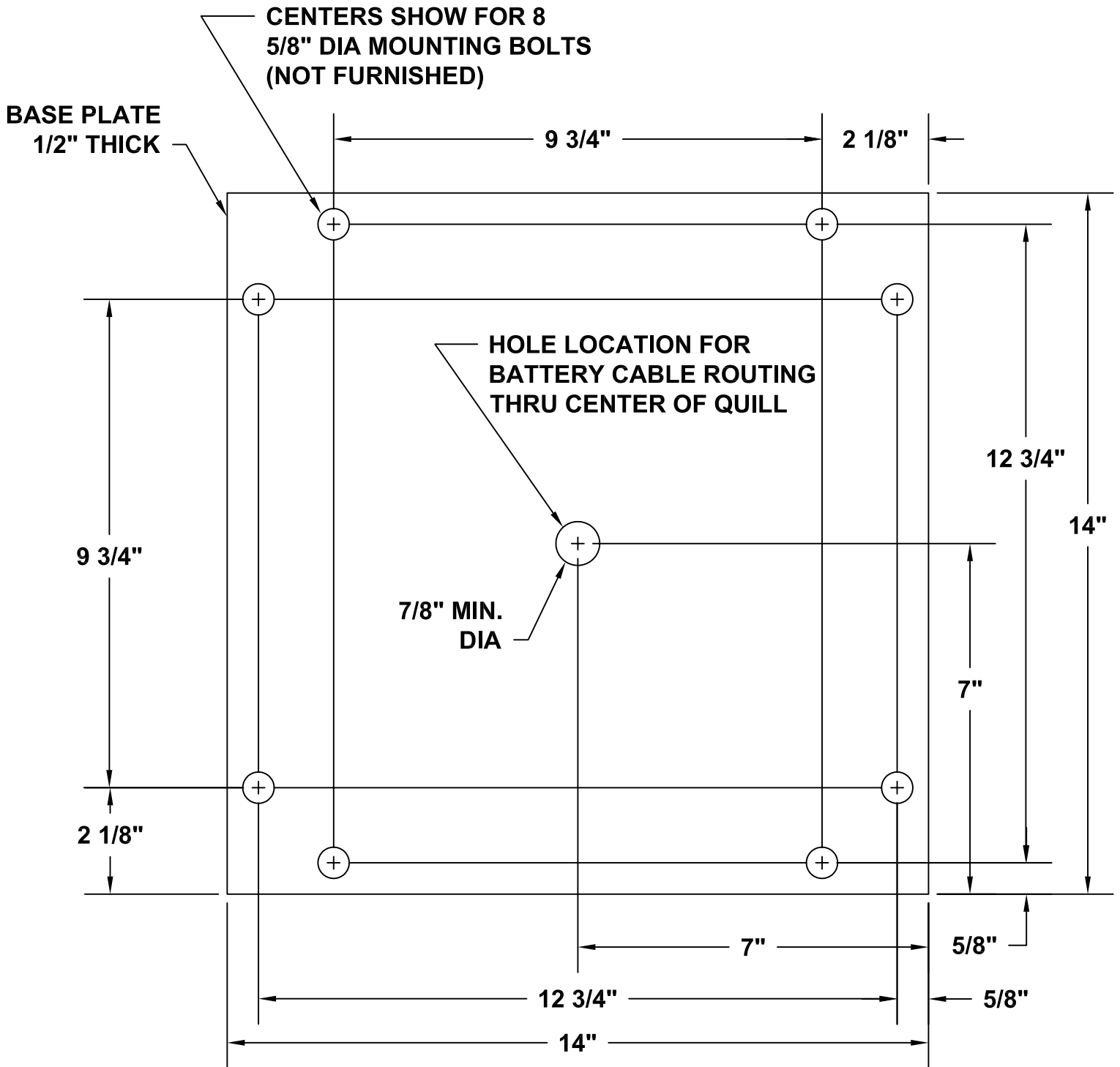

TITLE
17299 BASE MTG DIM

DATE
1-12-05C

SECTION
C100

ET6KR, ET10K(X)

SUPERSEDES
7-22-99B

I17390



ET10K(X) MAXIMUM CAPACITY CHART

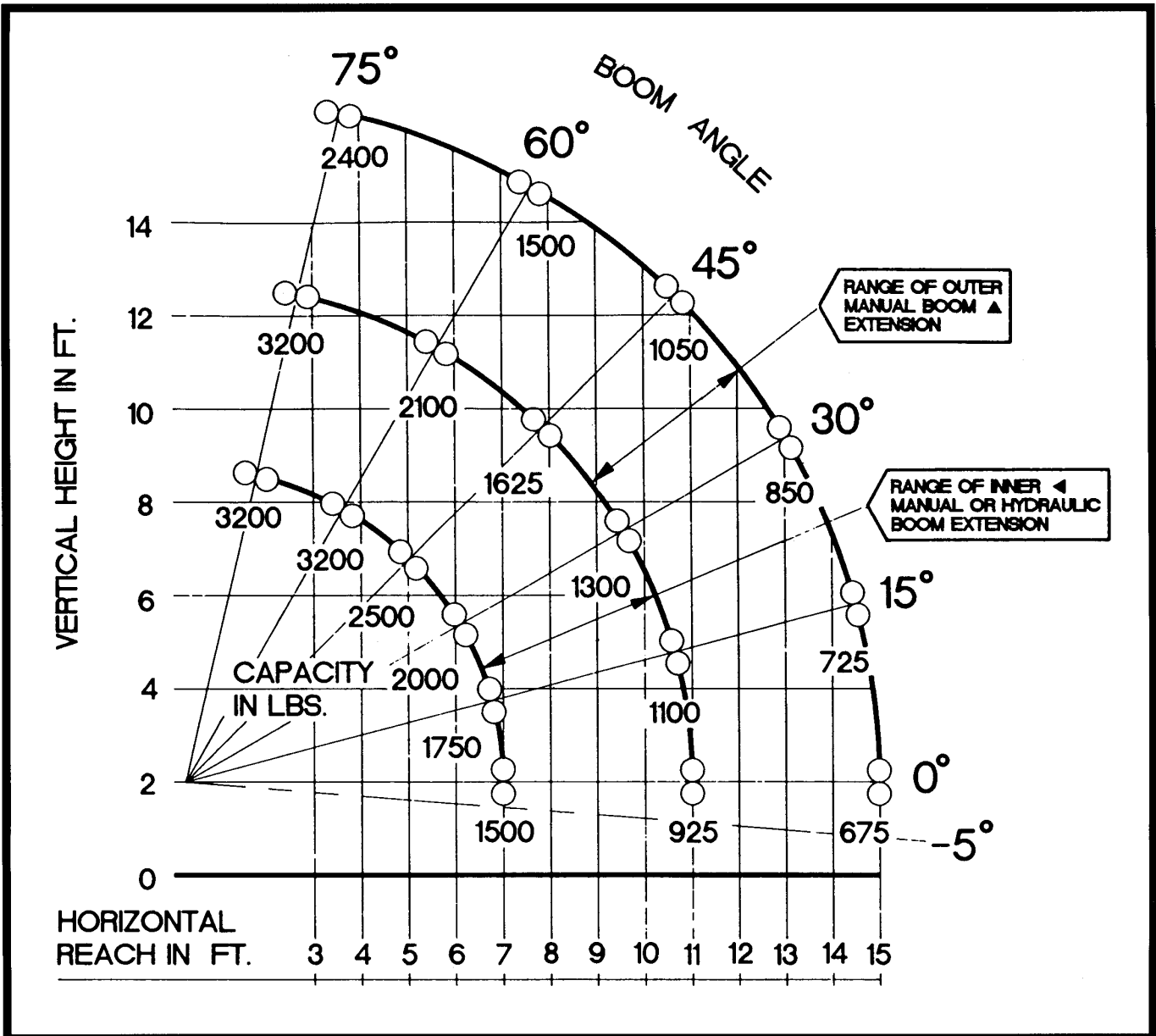

TITLE	MAX CAPACITY CHART
	ET10K(X)

DATE	7-1-98
SUPERCEDES	-

SECTION	C100
	19529

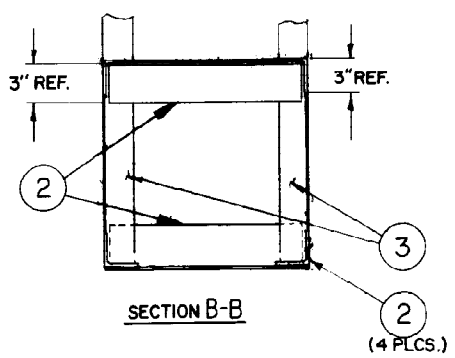

PART	DESCRIPTION	MINIMUM RECOMMENDED MATERIAL SIZE
1	TOP PLATE	$\frac{3}{8}$ " STEEL
2	CORNER POST	3" x 3" x $\frac{1}{4}$ " STEEL ANGLE
3	CROSS FRAME	2" x 4" x $\frac{1}{4}$ " W STRUCTURAL TUBING or 4" x 7.25 LB STANDARD STEEL CHANNEL
4	SHEAR WEB	12 Ga.
5	TOP PLATE REINFORCEMENT	$\frac{3}{8}$ " x 4" STEEL BAR
6	OUTRIGGER REINFORCEMENT PLATE	$\frac{3}{16}$ " THICK STEEL PLATE
7	GUSSET	$\frac{1}{4}$ " x 4" H.R. STEEL

IT IS THE SOLE RESPONSIBILITY OF THE INSTALLER TO INSURE THAT THE TOTAL STRUCTURE OF CRANE, TRUCK, AND OUTRIGGERS ARE STRUCTURALLY SOUND AND THAT THE COMPLETED VEHICLE HAS SUFFICIENT STABILITY AGAINST OVERTURNING.

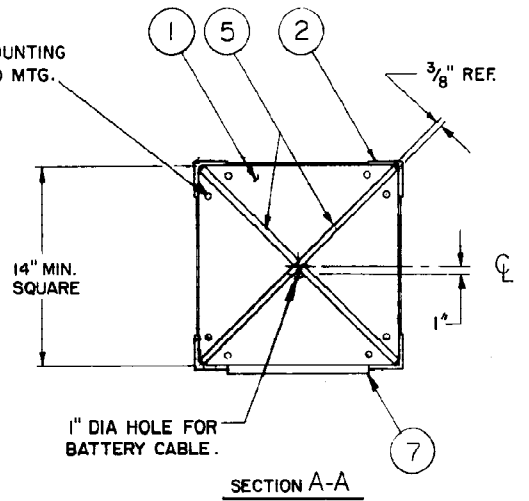
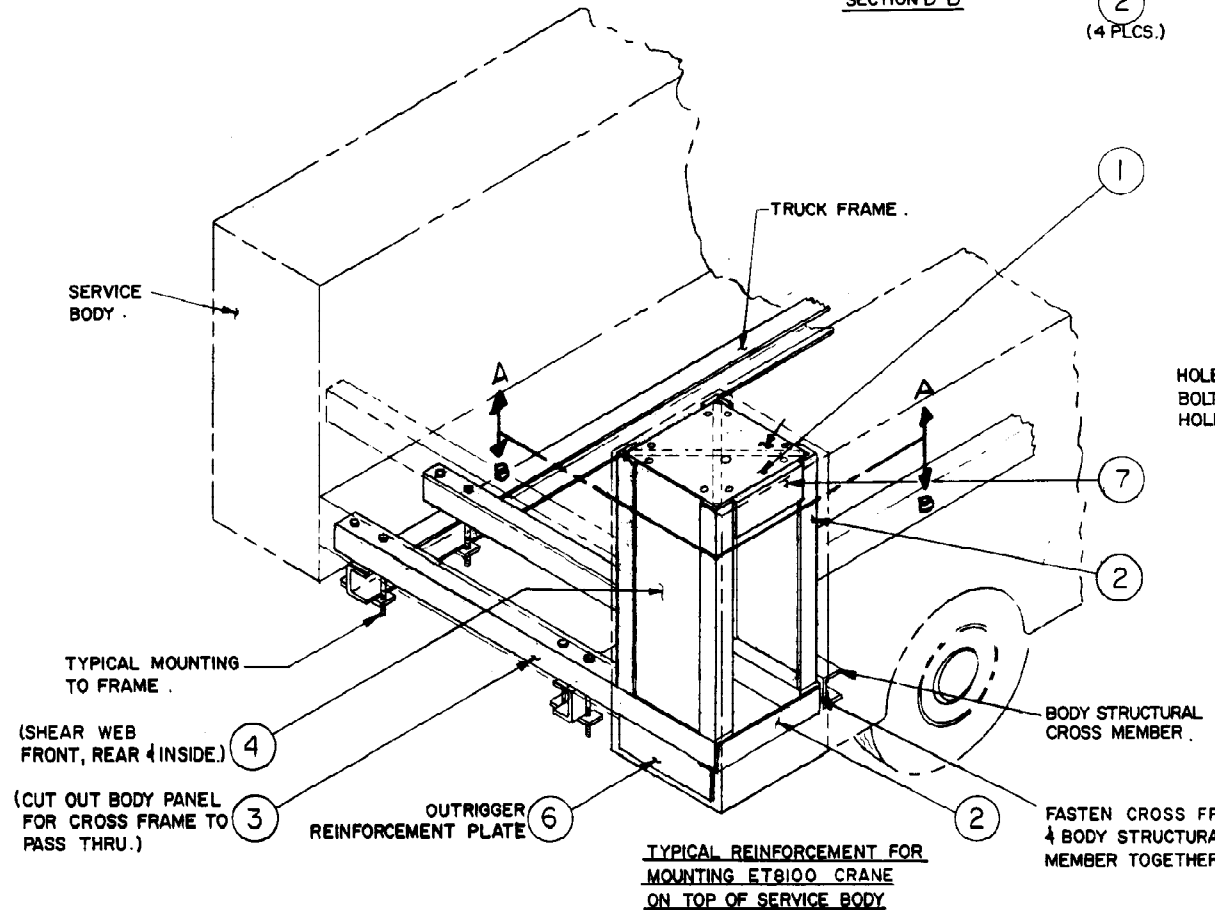

MANUFACTURING, INC.
CINCINNATI, OHIO

TITLE
INSTALLATION DRAWING

DATE
12-21-99B

SECTION
C100

▲ ET6KR, ET10K(X) CRANES

SUPERCEDES
6-19-98A

16938



17340-XX PEDESTAL

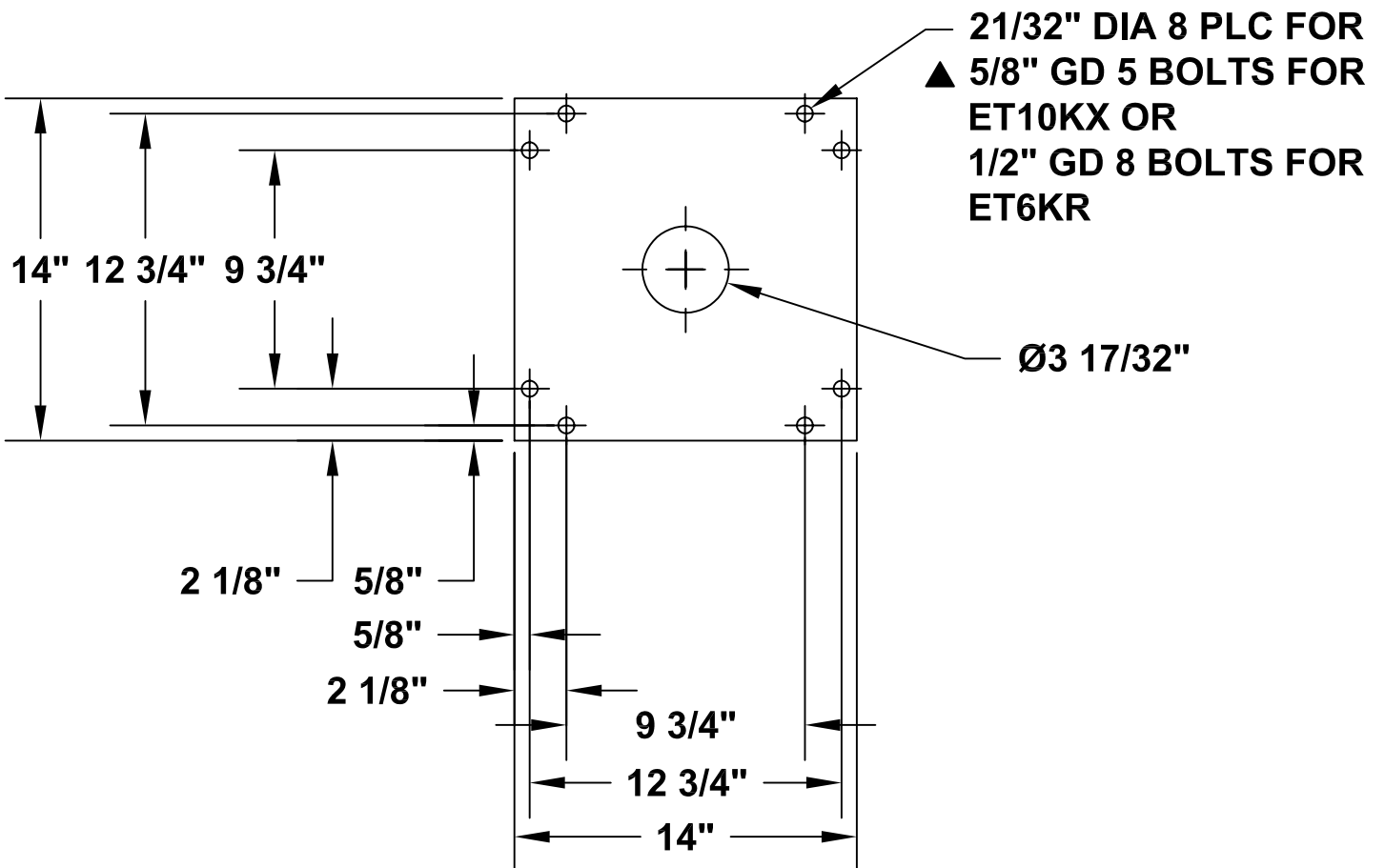
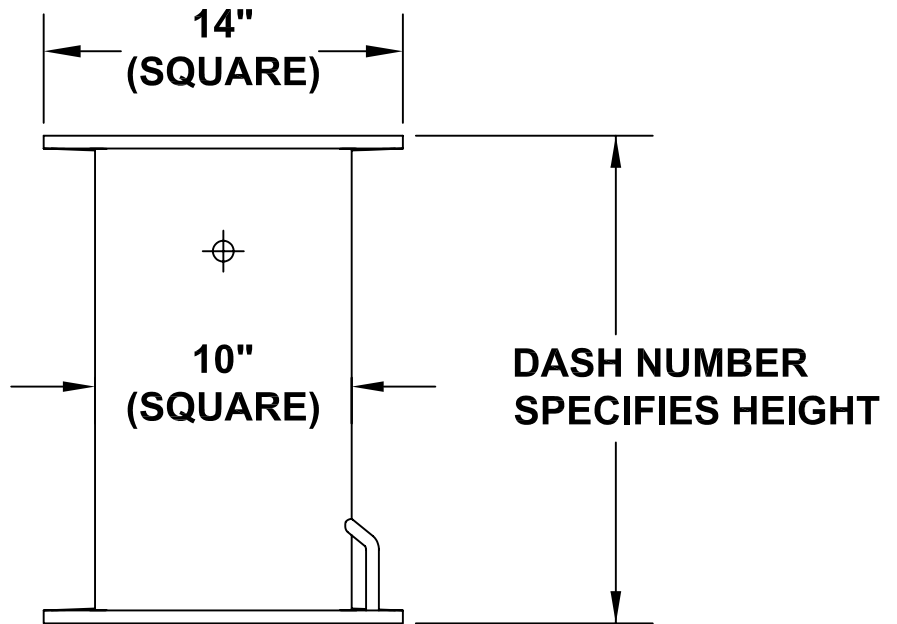

TITLE
17340 MOUNTING PEDESTAL
▲ ET6KR, ET10K(X) CRANES

DATE
11-1-04D
SUPERSEDES
1-2-03C

SECTION
C100
S17340

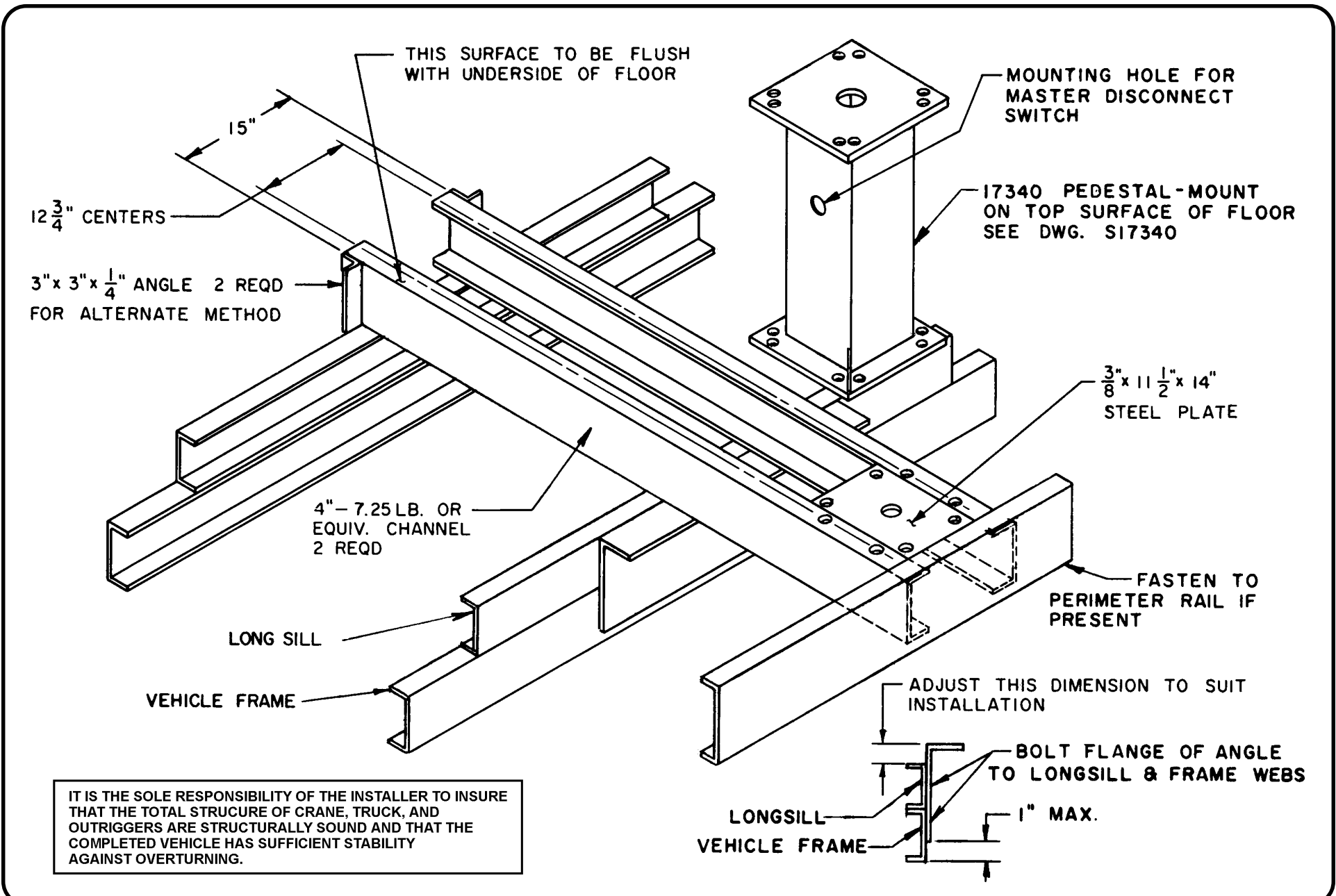

IT IS THE SOLE RESPONSIBILITY OF THE INSTALLER TO INSURE THAT THE TOTAL STRUCTURE OF CRANE, TRUCK, AND OUTRIGGERS ARE STRUCTURALLY SOUND AND THAT THE COMPLETED VEHICLE HAS SUFFICIENT STABILITY AGAINST OVERTURNING.



MANUFACTURING, INC.
CINCINNATI, OHIO

TITLE	INSTALLATION DRAWING	DATE	5-1-02C	SECTION	C100
	ET6KR, ET8100, ET10K(X) CRANES	SUPERCEDES	6-19-98B		117340

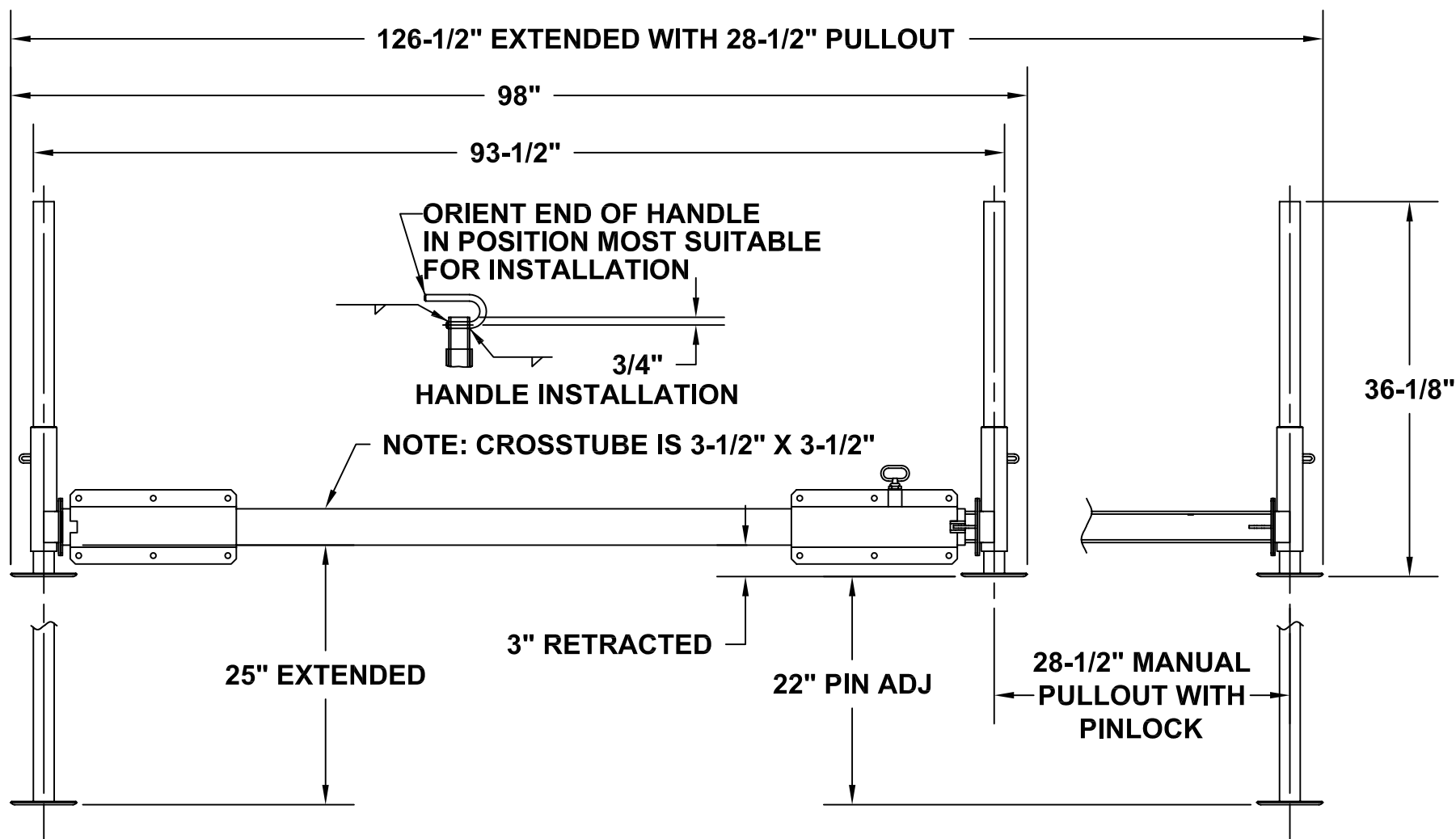

MANUFACTURING, INC.
CINCINNATI, OHIO

TITLE

INSTALLATION DRAWING

18500-P OUTRIGGER

DATE

1-12-05A

SUPERSEDES

11-12-03

SECTION

C100

22687

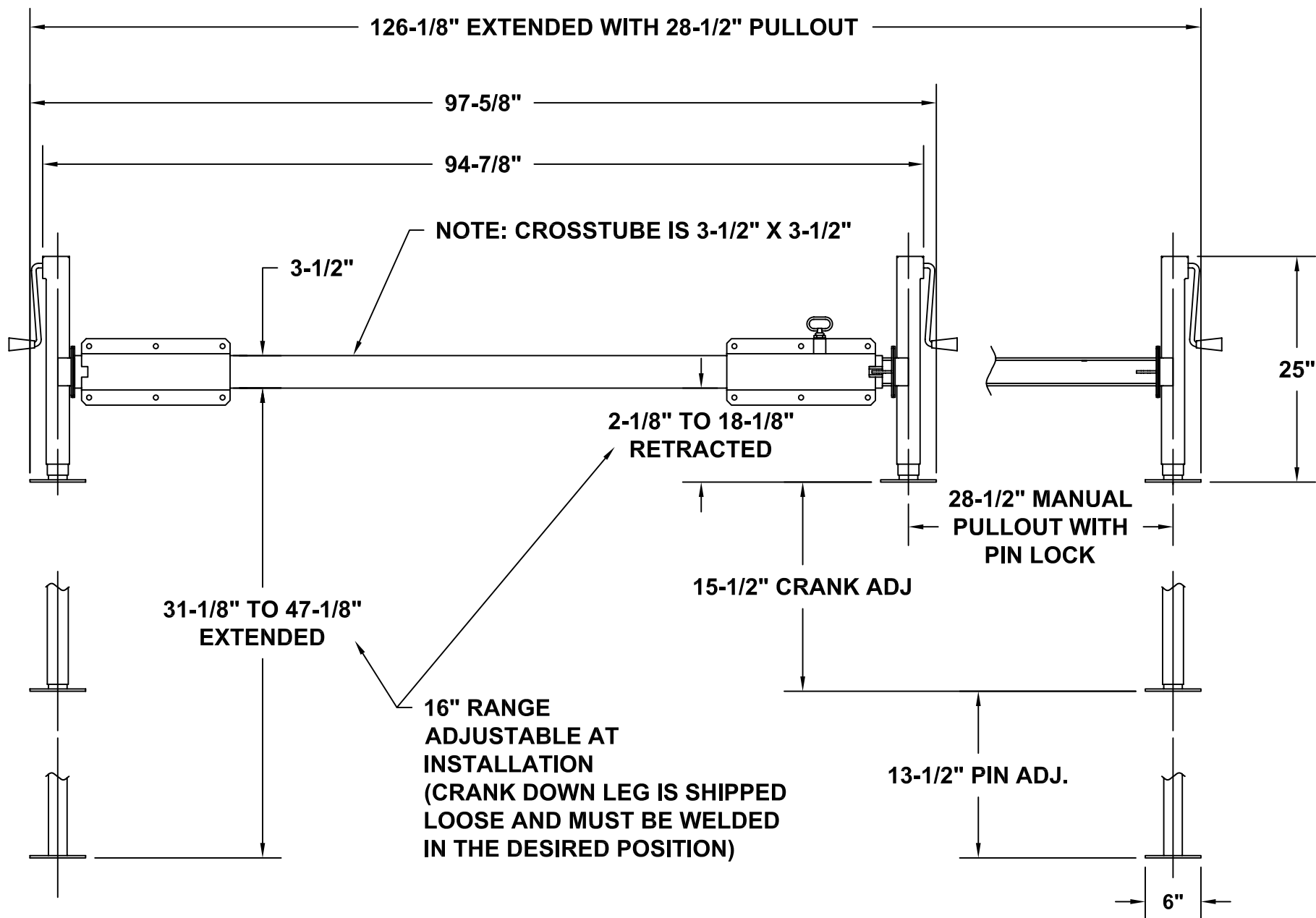

TITLE
INSTALLATION DRAWING
18500-CD OUTRIGGER

DATE
1-13-05A
 SUPERSEDES
11-11-03

SECTION
C100
22686



WARNING: THESE PRODUCTS ARE NOT FOR USE WITH PASSENGER LIFTS. THEY ARE NOT DESIGNED OR INTENDED TO BE USED WITH DEVICES THAT LIFT, SUPPORT OR OTHERWISE TRANSPORT PERSONNEL.

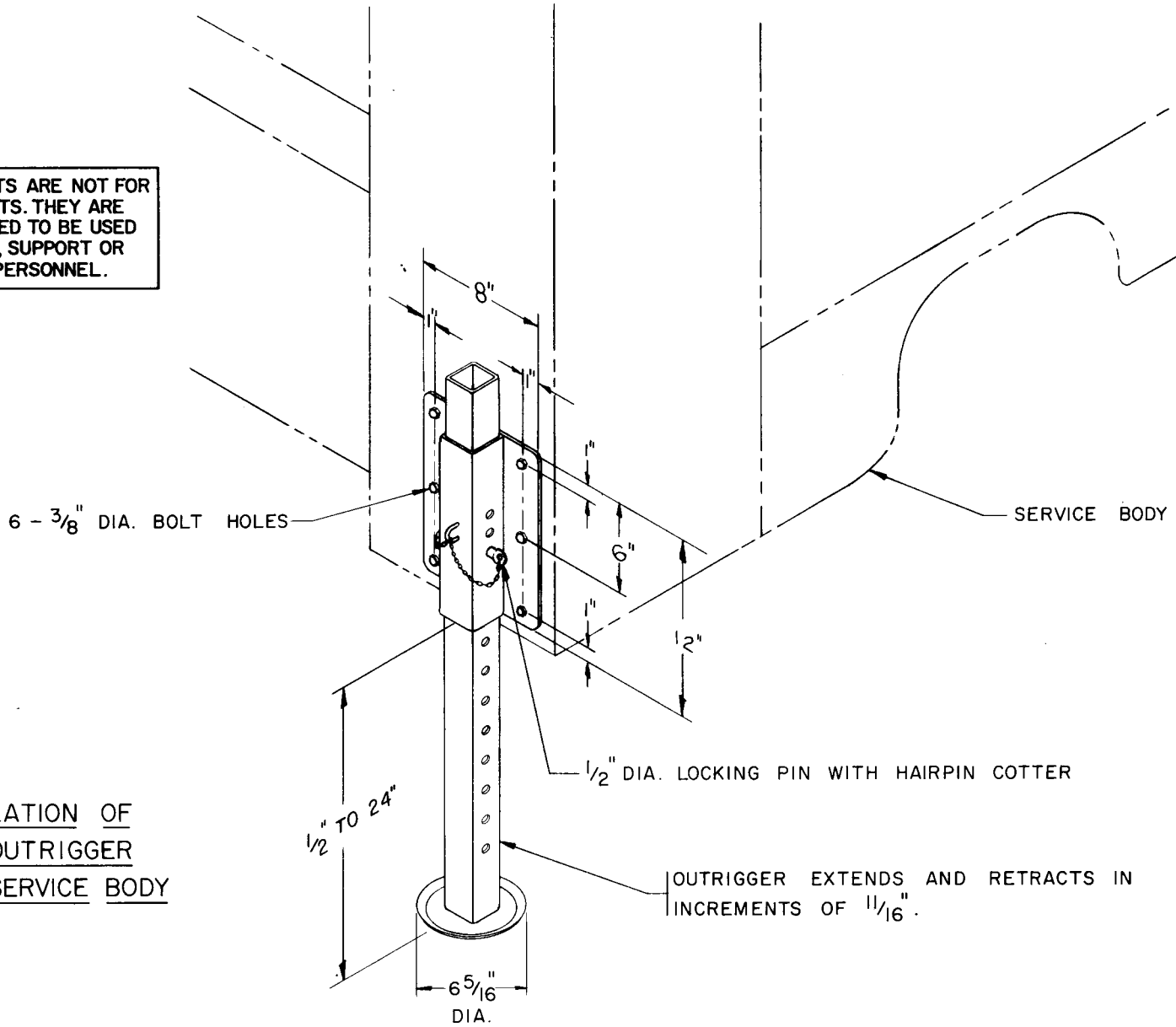

TYPICAL INSTALLATION OF 13500 MANUAL OUTRIGGER ON TRUCK WITH SERVICE BODY

VENTURO MANUFACTURING, INC.
CINCINNATI, OHIO

TITLE	DATE	SECTION
INSTALLATION DRAWING	6-17-98C	C100
ET5500MPB, ET6KM/R	SUPERCEDES 8-1-83B	13509



WARNING: THESE PRODUCTS ARE NOT FOR USE WITH PASSENGER LIFTS. THEY ARE NOT DESIGNED OR INTENDED TO BE USED WITH DEVICES THAT LIFT, SUPPORT OR OTHERWISE TRANSPORT PERSONNEL

**TYPICAL INSTALLATION OF 23961
MANUAL OUTRIGGER ON TRUCK
WITH SERVICE BODY EQUIPPED
WITH ET/HT25 SERIES CRANES**

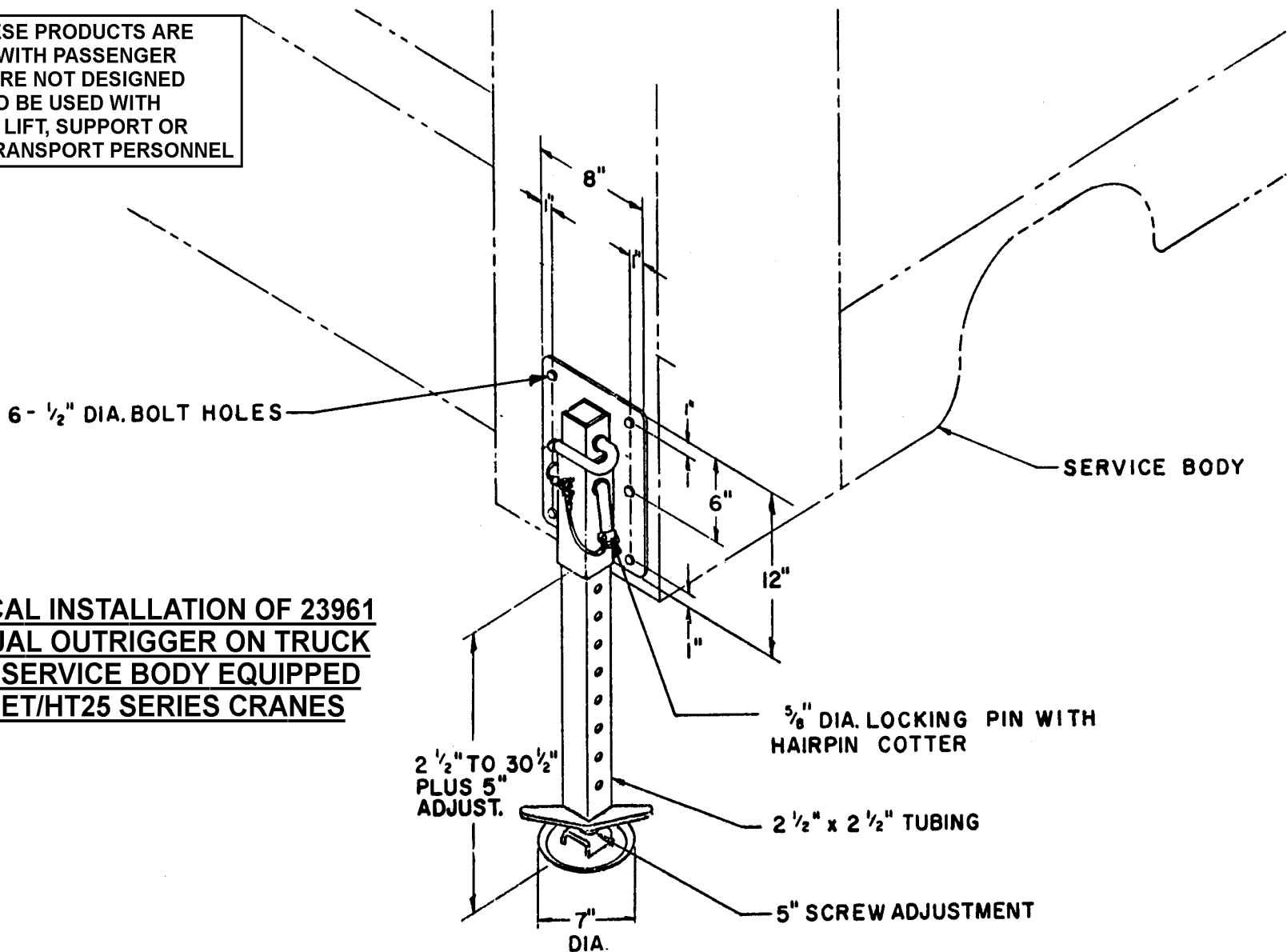

MANUFACTURING, INC.
CINCINNATI, OHIO

TITLE
INSTALLATION DRAWING

DATE
4-29-98D

SECTION
C100

ET10K(X), ET25K(X), HT25KX

SUPERCEDES
7-27-83C

I23961



PART No.	DESCRIPTION	'A'	'B'	'C'	'D'
11822-1	SHORT OUTRIGGER	19"	29"	19 ³ / ₄ "	6 ¹ / ₂ "
11822-2	LONG OUTRIGGER	27"	45"	27 ³ / ₄ "	9 ³ / ₄ "

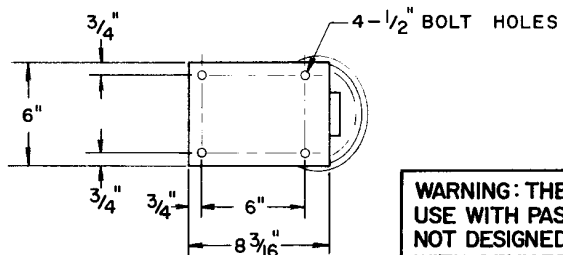

WARNING: THESE PRODUCTS ARE NOT FOR USE WITH PASSENGER LIFTS. THEY ARE NOT DESIGNED OR INTENDED TO BE USED WITH DEVICES THAT LIFT, SUPPORT OR OTHERWISE TRANSPORT PERSONNEL.

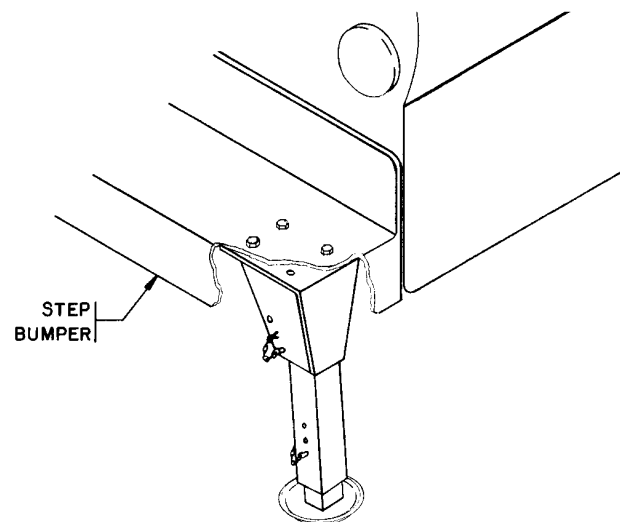
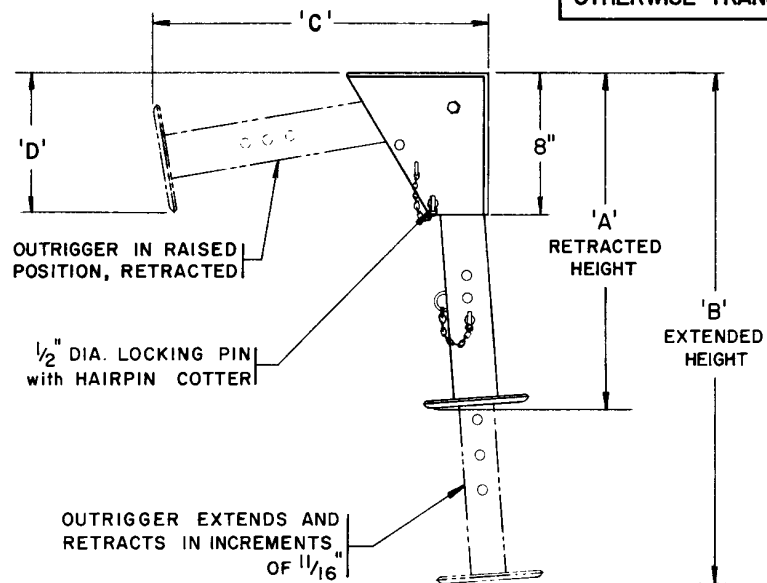

TYPICAL SHORT INSTALLATION
OUTRIGGER

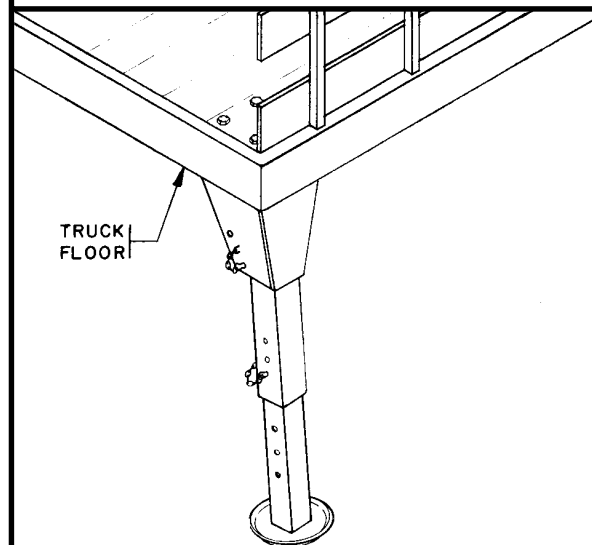

TYPICAL LONG INSTALLATION
OUTRIGGER



MANUFACTURING, INC.
CINCINNATI, OHIO

TITLE
INSTALLATION DRAWING

ET5500MPB, ET6KM/R

DATE
6-17-98C

SUPERCEDES
10-12-83B

SECTION
C100

13510



PART NO.	DESCRIPTION	'A'	'B'	'C'	'D'
23960-1	SHORT OUTRIGGER	20 1/2"	28 1/2"	21"	7 1/4"
23960-2	LONG OUTRIGGER	28 1/2"	44 1/2"	29"	10 1/2"

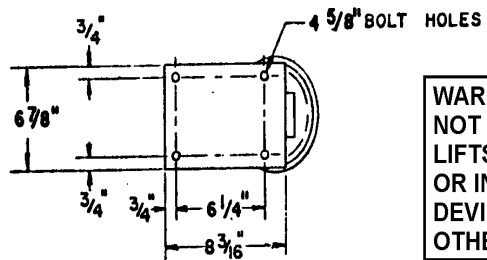

WARNING: THESE PRODUCTS ARE NOT FOR USE WITH PASSENGER LIFTS. THEY ARE NOT DESIGNED OR INTENDED TO BE USED WITH DEVICES THAT LIFT, SUPPORT OR OTHERWISE TRANSPORT PERSONNEL.

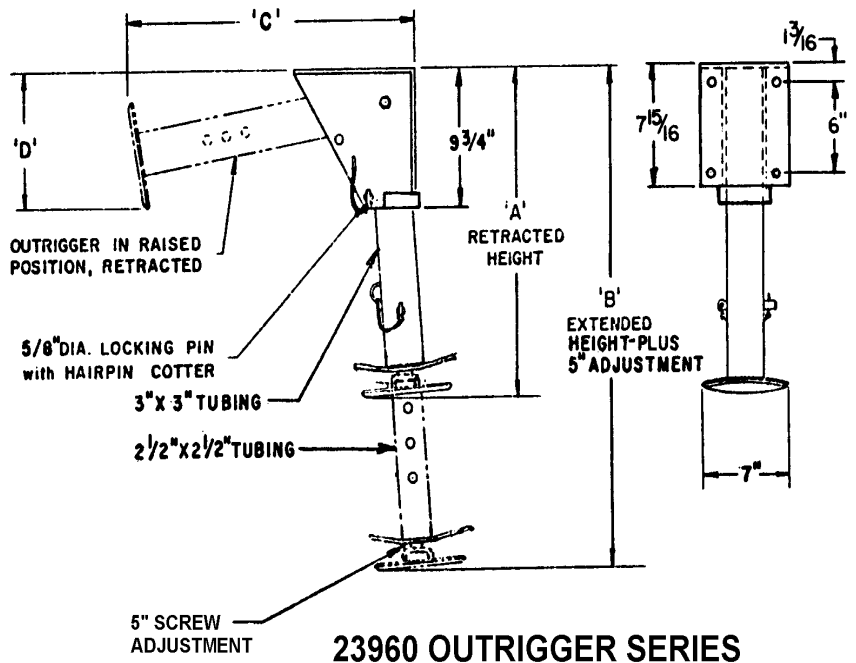

**23960 OUTRIGGER SERIES
ET/HT25 SERIES CRANES**

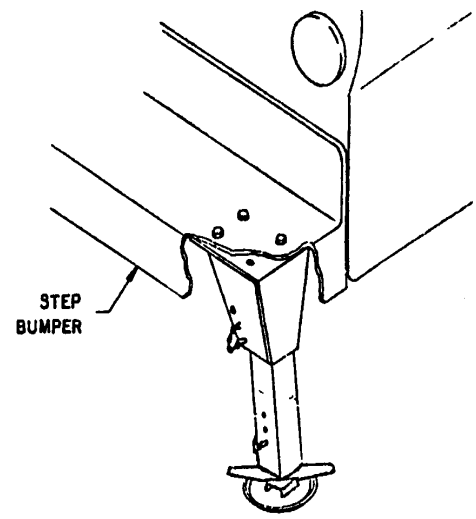

TYPICAL SHORT
OUTRIGGER INSTALLATION

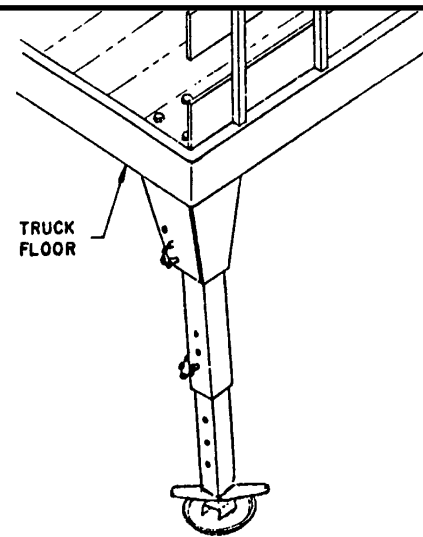

TYPICAL LONG
OUTRIGGER INSTALLATION



MANUFACTURING, INC.
CINCINNATI, OHIO

TITLE
INSTALLATION DRAWING

DATE
4-29-98C

SECTION
C100

ET10K(X), ET25K(X), HT25KX

SUPERCEDES
7-27-83B

123960



VEHICLE & CRANE MOUNTED ELECTRICAL HAZARD SIGN APPLICATION & INFORMATION

ET & HT CRANE SERIES



- ▲ SIGN NO. 15393A DISPLAYS THE INTERNATIONAL SYMBOL FOR ELECTRICITY AND WARNS OF DANGER FROM AN ELECTRICALLY CHARGED VEHICLE, CRANE, OR LOAD. FOUR ARE RECOMMENDED (ONE FOR EACH SIDE AND ONE FOR EACH END OF VEHICLE) TO BE APPLIED IN LOCATIONS WHICH ARE READILY VISIBLE TO GROUND PERSONNEL.



- ▲ SIGN NO. 15401 PROVIDES ADDITIONAL WARNING OF LEGAL REQUIREMENTS WHEN OPERATING NEAR HIGH VOLTAGE LINES. THIS SIGN IS PLACED ON THE CONTROL PENDANT SIDE OF BOOM.

REQUIRED MINIMUM CLEARANCES REFERRED TO ON SIGN NO. 15401

REQUIRED CLEARANCES FROM OVERHEAD HIGH-VOLTAGE LINES

NOMINAL VOLTAGE (kV) (PHASE TO PHASE)	MINIMUM REQUIRED CLEARANCE (FEET) *
0 - 50	10
over 50 - 200	15
over 200 - 350	20
over 350 - 500	25
over 500 - 750	35
over 750 - 1000	45

REQUIRED CLEARANCES FROM ENERGIZED HIGH-VOLTAGE CONDUCTORS (WHILE IN TRANSIT)

NOMINAL VOLTAGE (kV) (PHASE TO PHASE)	MINIMUM REQUIRED CLEARANCE (FEET) *
0 - 0.75	4
over 0.75 - 50	6
over 50 - 345	10
over 345 - 750	16
over 750 - 1000	20

* NOTE: ENVIRONMENTAL CONDITIONS SUCH AS FOG, SMOKE, OR PRECIPITATION MAY REQUIRE INCREASED CLEARANCES



MFG., INC.
CINCINNATI, OHIO

TITLE	DATE	SECTION
INSTALLATION DWG	5-15-02H	C150
ET & HT CRANE SERIES	SUPERCEDES 5-13-97G	15394

**CRANE SAFETY AND HAZARDS**

ET5500MPB/R, ET6KMPB/R, ET8100R, ET10K(X), ET18K(X), ET25K(X)

CAUTIONS

1. INSPECT VEHICLE AND CRANE, INCLUDING OPERATION, PRIOR TO USE DAILY.
2. DO NOT USE THIS EQUIPMENT EXCEPT ON SOLID, LEVEL SURFACE WITH CRANE MOUNTED ON FACTORY-RECOMMENDED TRUCK.
3. BEFORE OPERATING THE CRANE, REFER TO MAXIMUM LOAD (CAPACITY) CHART ON CRANE FOR OPERATING (LOAD) LIMITATIONS.
4. DO NOT OPERATE, WALK, OR STAND BENEATH BOOM OR A SUSPENDED LOAD.
5. ATTACH PENDANT CORD SUPPORT SNAP TO ATTACHMENT POINT BEFORE PLUGGING IN PENDANT.
6. UNPLUG PENDANT AND SHUT OFF MASTER DISCONNECT SWITCH WHEN CRANE NOT IN USE.
7. FOR TRAVEL, BOOM MUST BE IN STOWED POSITION.

DANGER

- THIS CRANE IS NOT A PASSENGER LIFT
- IT IS NOT DESIGNED OR INTENDED TO BE USED TO LIFT, SUPPORT, OR OTHERWISE TRANSPORT PERSONNEL.

YOU MUST NOT OPERATE THIS CRANE UNLESS

1. YOU HAVE BEEN TRAINED IN THE SAFE OPERATION OF THIS CRANE
AND
2. YOU KNOW AND FOLLOW THE SAFETY AND OPERATING RECOMMENDATIONS CONTAINED IN THE MANUFACTURER'S MANUALS, YOUR EMPLOYER'S WORK RULES, AND APPLICABLE GOVERNMENT REGULATIONS. AN UNTRAINED OPERATOR SUBJECTS HIMSELF AND OTHERS TO DEATH OR SERIOUS INJURY.

ELECTROCUTION HAZARD

- THIS MACHINE IS NOT INSULATED.
- MAINTAIN SAFE CLEARANCES FROM ELECTRICAL LINES AND APPARATUS.
- YOU MUST ALLOW FOR BOOM SWAY, ROCK OR SAG, AND ELECTRICAL LINE AND LOADLINE SWAYING.
- THIS LIFTING DEVICE DOES NOT PROVIDE PROTECTION FROM CONTACT WITH OR PROXIMITY TO AN ELECTRICALLY CHARGED CONDUCTOR.
- YOU MUST MAINTAIN A CLEARANCE OF AT LEAST 10 FEET BETWEEN ANY PART OF THE CRANE, LOADLINE, OR LOAD, AND ANY ELECTRICAL LINE OR APPARATUS CARRYING UP TO 50,000 VOLTS. ADDITIONAL CLEARANCE IS REQUIRED FOR VOLTAGES IN EXCESS OF 50,000 VOLTS. REFER TO DRAWING 15394 FOR ADDITIONAL INFORMATION.
- **DEATH OR SERIOUS INJURY** WILL RESULT FROM CONTACT OR INADEQUATE CLEARANCE.

MFG., INC.
CINCINNATI, OHIO

TITLE

INSTALLATION DWG

DATE

7-29-03G

SECTION

C150**ET5500MPB-ET25KX**

SUPERCEDES

10-14-97F**850711**



IMPORTANT

ADEQUATE WIRING IMPERATIVE FOR PROPER OPERATION

1. PROPER GROUND PATH - SEE DWG 15660
2. CURRENT DRAW IS SEVERAL HUNDRED AMPERES - ADEQUATE WIRE SIZE AND BATTERY CAPACITY IS ABSOLUTELY ESSENTIAL (SEE CHART BELOW.)

MINIMUM WIRE GAUGE AND BATTERY SIZE

MODEL	TOTAL LENGTH OF CABLE (FT)*								12 VOLT BATTERY REQUIREMENTS	
	0-20	21-25	26-30	31-40	41-50	51-60	61-70	71-80	CCA (A)**	RC (MIN)***
CE6K CT2000 CT2003/4/5 DT7K	#4	#4	#2	#2	#1	#0	#0	#00	350	100
ET5500MPB ET5500R ET6KMPB ET6KR ET10K	#2	#2	#1	#0	#00	NOTRECOMMENDED			450	100
ET10KX	#2	#2	#1	#0	#00	NOTRECOMMENDED			550	150
ET25K ET25KX	SEE DRAWING I24600 FOR CABLE AND BATTERY REQUIREMENTS									

* INCLUDES GROUND CABLE

** CCA=COLD CRANKING AMPS AT 0' F.
THE CCA RATING IS A MEASURE OF THE ABILITY OF THE BATTERY TO DELIVER A HIGH CURRENT FOR A SHORT PERIOD OF TIME.

*** RC=RESERVE CAPACITY IN MINUTES AT 25 AMPS AND 80' F.
THE RC RATING IS A MEASURE OF THE PERIOD OF TIME THE BATTERY CAN SUPPLY A GIVEN CURRENT WITHOUT RECHARGING.



MFG., INC.
CINCINNATI, OHIO

TITLE
CABLE & BATTERY

CE, CT, DT, & ET

DATE
8-10-00R

SUPERCEDES
3-3-99Q

SECTION
C200

711105



Important: The crane must make connection with the negative of the battery. To insure this, install a #2 gauge grounding strap from the engine to the truck frame (required if negative from battery is connected to the engine.) Also, install a #2 gauge grounding strap from the crane base to the truck frame, included with ET6R, ET10K(X), ET25K, & ET25KX cranes.

Failure to accomplish the above mentioned steps may result in intermittent operation of electric crane.

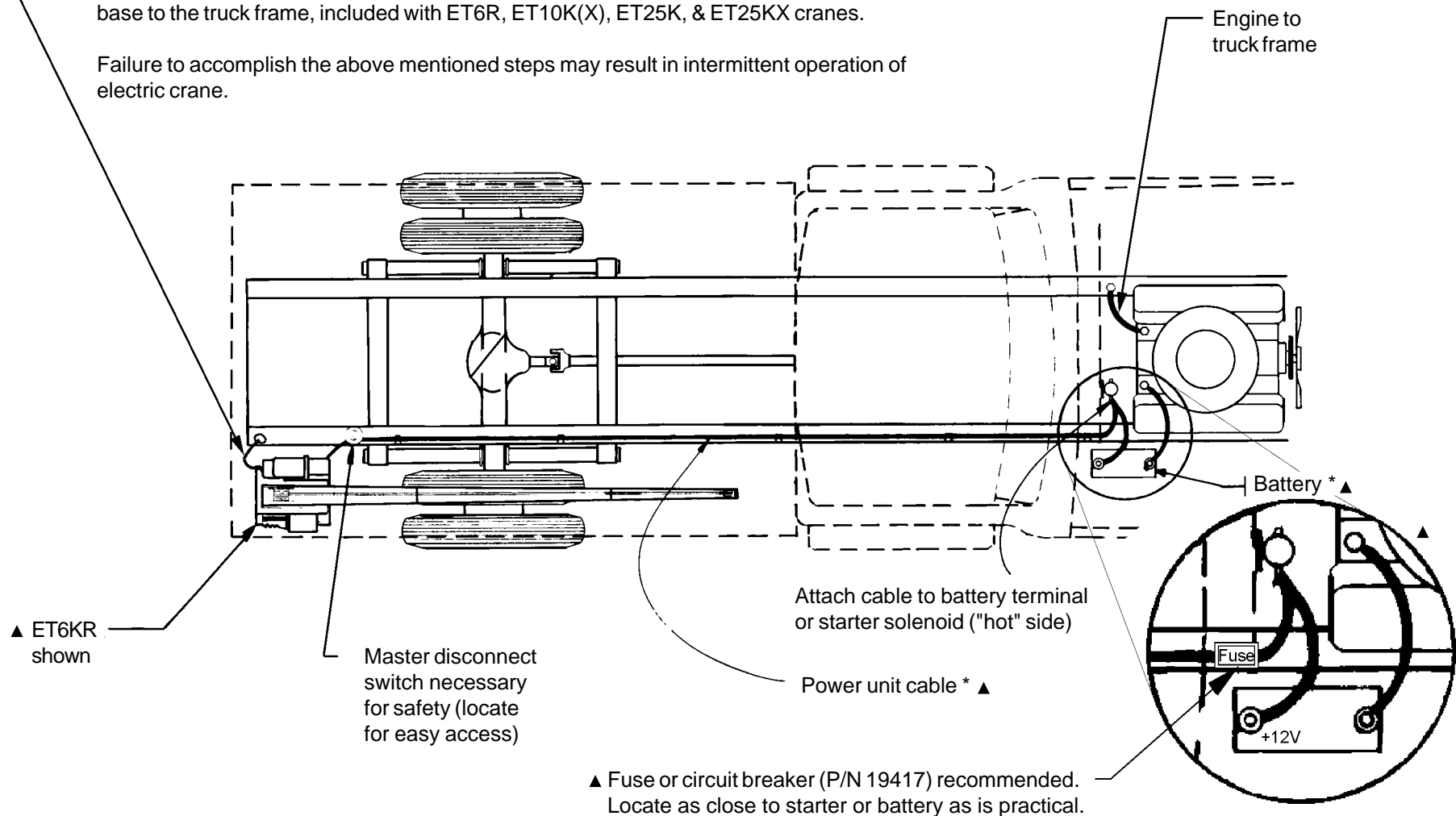

▲ * Note: See Dwg 711105 for recommended battery and cable specifications



MANUFACTURING, INC.
CINCINNATI, OHIO

TITLE
INSTALLATION - BATTERY CABLE

DATE
1-15-02E

SECTION
C200

WINCH & CRANE

SUPERCEDES
11-7-01D

15660



CRANE OPERATION AND MAINTENANCE INSTRUCTIONS

ET10KX

SAFETY

Before operating this crane, read and understand these instructions, the 850711 Crane Safety and Hazards Information Sheet, and review all safety & instruction labels on the crane.

CRANE INSPECTION

Before operating this crane, inspect for wear, damage, or oil leakage. After the wire rope has been run out, check for wear, kinks, and broken strands. Check the hook and safety latch for damage. Correct any problems before using the crane.

CAPACITY

Before operating this crane, review the capacity diagrams on the 891014 Capacity Information Sheet as well as the capacity charts on the sides of the boom to relate the load to be lifted to the boom length and angle. The boom angle is shown by a gravity arrow.

SNATCH BLOCK

If the load exceeds 1600 lbs. or if reduced winching speed for better control of smaller loads is required, use the snatch block to rig the crane for two part line operation. Refer to drawing 17450 or 17470 for this.

CONTROLS

This crane is operated by a remote control pendant. The pendant should be unplugged and stored in a compartment or the cab when the crane is not in use.

Before plugging the pendant in, inspect the plug, socket, cord, pendant head, and switches for damage. Actuate all four switches both ways to verify that they all have the same feel and sound and that they return to the center position.

Plug the pendant into the socket on the right side of the crane and snap the strain relief tether to the crane housing.

Turn on the Master Disconnect Switch. Use "Winch Down" to release tension on the wire rope to unhook it from storage tie down position.

Use "Boom Up" to elevate the boom from the boom rest position.

Check all control functions to see that they are working correctly.



TITLE	DATE	SECTION
INSTALLATION DWG	10-23-97A	C200
ET10KX	SUPERCEDES 5-30-90	900530a



CONTROL FUNCTIONS

WINCH "UP" and "DOWN" - Raises and lowers the load with the wire rope.

POWER ELEVATION - "Up" raises the boom elevation by operating the valves and the electric hydraulic power unit. "Down" operates a solenoid release valve mounted on the cylinder to lower the load and/or boom by gravity at a controlled rate. A check valve on the cylinder prevents the boom from coming down if a hose breaks. A flow control valve controls lowering rate.

POWER EXTENSION - "Out" and "In" extend and retract boom 4 ft. under power. A pilot operated check valve on the boom prevents the boom retracting without hydraulic power or if a hose should break. A flow control valve controls retract rate under load.

POWER ROTATION - "L" & "R" control direction of rotation. The ET10KX can be rotated continuously thru 360 degrees or more. There are no internal restrictions on the number of rotations in any direction.

CONTROL PRIORITY SYSTEM - As a built in safety feature, the operator can perform only one major and one minor function at any one time. Major functions are rotation, winching up of a load, and elevating, extending and retracting the boom. Minor functions are winching down, and lowering the boom.

- a. "Winch Up" has priority over "Boom Up", "Boom Out & In", and "Rotation"
- b. "Boom Up" has priority over "Boom Out & In", and "Rotation".
- c. "Boom Out & In" have priority over "Rotation".
- d. "Boom Down" and "Winch Down" can be operated with any function.

CRANE OPERATION

Avoid rapid reversal of the Winch and Rotation Control Switches. The high inrush current to the motors during reversal can reduce the life of the contactors and the motor brushes and commutators.

When operating "Winch Up", "Boom Down" or "Boom Out" always maintain clearance between the boom head and the snatch block or hook.

Do not lift or drag a load sideways using any of the crane functions. The boom has much lower bending strength sideways than in the vertical direction.



TITLE	DATE	SECTION
INSTALLATION DWG	10-23-97A	C200
ET10KX	SUPERCEDES 5-30-90	900530b



OVERLOAD ALARM SYSTEMS (OPTIONAL)

This crane may be equipped with an optional overload alarm system.

1. Overload alarm horn sounds if rated load is exceeded at any reach.
2. If alarm sounds, RAISE Boom or LOWER Winch to remove overload.
3. Always RAISE Boom slightly before lifting load - Warning system INOPERATIVE when cylinder is completely bottomed.
4. Alarm can be tested by raising Boom against UP limit stop.

MANUAL TELESCOPIC BOOM

The 7' to 15' boom has a 4' manual telescoping section in addition to the 4' power extension. A toggle pin locks the boom into either the extended or retracted position.

TRUCK SETUP & OUTRIGGERS

1. The truck should be parked on ground that is as level and as firm as possible when using the crane.
2. The center of the crane should be positioned close enough to the job so that it can be operated at a reach that puts the load within the rated capacity of the crane.
3. Set the vehicle parking brake and put the vehicle transmission in "park" or a low gear unless the engine is to be left running.
4. Deploy the outriggers to help stabilize the vehicle against rocking or overturning when lifting with the crane.

PREPARATION FOR TRAVEL

1. Return the outriggers to the stowed position. Install and secure all pins.
2. Stow the crane boom in the boom support.
3. Hook the winch line to a tie down point on the body or pedestal and apply tension.
4. TURN OFF THE MASTER DISCONNECT SWITCH.
5. Unplug the control pendant and store in a body compartment or the cab.



WARNING

- The pendant (or receiver) plug must be unplugged from the crane socket and the Master Disconnect (power) switch must be turned "off" when the crane is not in use! Leaving the pendant (or receiver) connected and the power on when not in use may result in dangerous, unintentional activation of the crane functions."



MFG., INC.
CINCINNATI, OHIO

TITLE
INSTALLATION DWG

ET10KX

DATE
5-18-04B

SUPERCEDES
10-23-97A

SECTION
C200

900530c



MAINTENANCE

Crane requires only periodic lubrication. As a standard procedure this can be done at the time the vehicle is serviced. Rotation bearings are self - lubricating. Fill Winch & Rotation Gear Boxes to level of the side plug with S.A.E. 85W/140 Hypoid Lubricant.

Chains should be oiled lightly (DO NOT GREASE). Excess oil or grease will collect road grit and cause excessive chain wear. Moly filled chassis grease should be applied by pressure grease gun to fittings on each end of rotation worm shaft and on rotation gear teeth thru port at rear of crane.

Fill electric hydraulic boom elevation, power unit reservoir to oil level line with boom down. Use Automatic Transmission Fluid Type "A" or Type "B" (Dexron). Below 20 degrees F. add 3/4 pt. Kerosene. Drain and refill with Dexron ATF when weather warms up. Check periodically or when boom action slows down.



TITLE	DATE	SECTION
INSTALLATION DWG	10-23-97A	C200
ET10KX	SUPERCEDES 5-30-90	900530d



SELECTION

The chart below shows the maximum working load and breaking strength of 7 X 19 Galvanized AIRCRAFT Grade Wire Rope in various diameters. The breaking strength is 3-1/2 times the maximum working load. Do not use wire rope with a Maximum Working Load rating less than the single line capacity of the crane. Use of wire rope diameter larger than the size furnished with the crane will reduce the fatigue life of the wire rope.

<u>WIRE ROPE DIAMETER</u>	<u>MAXIMUM WORKING LOAD</u>	<u>BREAKING STRENGTH</u>
1/8"	570 lbs	2000 lbs
5/32"	800 lbs	2800 lbs
3/16"	1200 lbs	4200 lbs
7/32"	1600 lbs	5600 lbs
1/4"	2000 lbs	7000 lbs
5/16"	2800 lbs	9800 lbs
3/8"	4114 lbs	14400 lbs

INSTALLATION

1. Unwind coil of rope by rolling it along floor. This will prevent kinking.
2. Most VENTURO Cranes are provided with a slot in the winch drum side plate for attaching the end of the wire rope with a stop collar. A hole in the housing allows access for the end of the wire rope when inserted thru the slot.

The ET20K(X) & ET25K(X) Cranes have a clamp built into the winch drum and do not use a stop collar.

3. THERE MUST ALWAYS BE AT LEAST (3) TURNS OF WIRE ROPE ON THE DRUM WHEN UNDER LOAD.



MFG., INC.
CINCINNATI, OHIO

TITLE	DATE	SECTION
WIRE ROPE SPECS	10-23-97G	WC 200
VENTURO WINCH & CRANE	SUPERCEDES 4-27-92F	711006



▲ REMTRON RADIO REMOTE CONTROL

▲ (20410, 20412 & 20414)

INSTALLATION

Mounting locations:

On-crane mounting:

For cranes without the "In-Compartment Controls" option, where the pendent/receiver connector plugs into a connector mounted on the crane housing, the receiver must be mounted directly on the crane as follows.

The **ET10KX** model without "In-Compartment Controls" requires the radio to be mounted on the rear of the crane housing with the cable and antenna facing downward as shown. Mounting the radio in this location will obscure several decals. Replacement decals (decals 15390A instructions, 15391B warning, 15392 warning) have been included in the retrofit kit and should be installed as close to the original locations as possible.

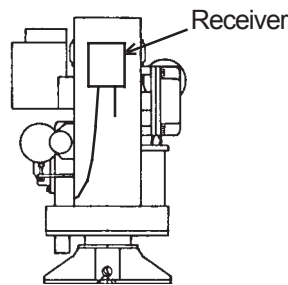

The **HT40/50KX** model without "In-Compartment Controls" requires the radio to be mounted on the right side of the crane's rear cover with the cable and antenna facing downward as shown.

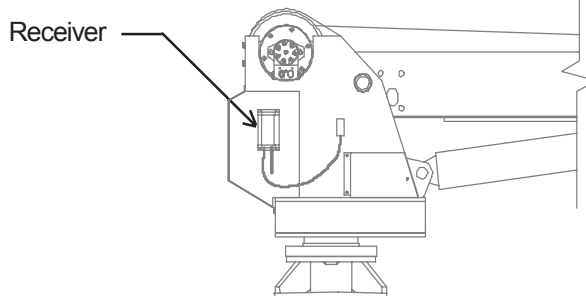

WARNING

- The master disconnect (power) switch must be turned off when the crane is not in use! Leaving the power on when not in use may result in dangerous, unintentional activation of the crane functions.

VENTURO

MFG., INC.
CINCINNATI, OHIO

TITLE	INSTALLATION DWG
RADIO REMOTE CONTROL	

DATE	7-25-03A
SUPERCEDES	2-10-03

SECTION	C200
	20415A



▲ REMTRON RADIO REMOTE CONTROL

Remote antenna location:

Some applications may not provide adequate radio reception and therefore may require mounting the antenna in a remote location from the receiver. A remote antenna mounting kit (part number 20965) includes an extension cable and antenna mounting bracket. Note that a replacement antenna, part number 20966, is available but is not included in the remote antenna mounting kit.

- ▲ It is suggested that in applications requiring remote mounting of the antenna, that a high location be chosen such as on top of the truck body but in a location which is not vulnerable to damage. The remote antenna mounting location must provide line of sight access between the transmitter and receiver.

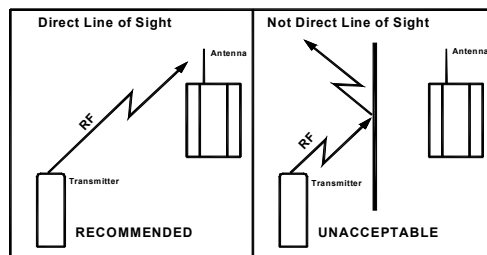

In-compartment mounting:

For cranes with the "In-Compartment Controls" option the radio will be mounted inside the body compartment where the pendant/receiver connector is located. In order to provide full radio range the receiver must be mounted such that a line of sight path to the transmitter is provided, Note that the compartment door must remain open during operation to minimize interference with radio transmissions.

Mounting instructions for all locations:

Locate the radio as described above and mark for mounting hardware making sure that both drilling and installation of the mounting hardware will not cause damage or interference with other components. Drill four .25 inch diameter clearance holes for the mounting hardware. Install the four #10x.75 long screws with flat washers through the mounting flanges on the receiver and through the mounting surface. Secure with the flat washers, lock washers and nuts provided. Note that one mounting flange has a metal ground tab. Star washers should be installed between the metal tab and hardware as well as between the mounting surface and hardware as shown. Install antenna and plug receiver connector into the socket to operate the crane.

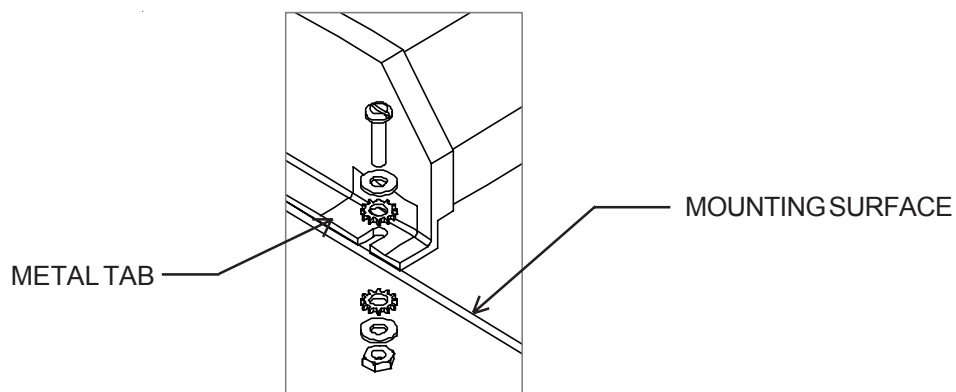

The transmitter is powered by a single 9V alkaline battery which may be replaced by removing the 4 screws from the transmitter housing and separating the 2 halves. Be sure to carefully align the two housing halves when reassembling the transmitter.



MFG., INC.
CINCINNATI, OHIO

TITLE	INSTALLATION DWG
RADIO REMOTE CONTROL	

DATE	7-25-03A
SUPERCEDES	2-10-03

SECTION	C200
	20415B



▲ REMTRON RADIO REMOTE CONTROL

▲ (20410, 20412 & 20414)

OPERATION

To operate the crane the receiver plug must be plugged into the socket and power must be switched on. The indicator on the receiver will light when it is powered and ready. The indicator will flash when the receiver is receiving a properly coded signal from the transmitter. The receiver requires "line of sight" access to the transmitter for full range operation. For cranes with in-compartment controls the compartment door must be left open during operation of the crane in order to avoid obstructing the radio signal.



WARNING

- The receiver connector must be unplugged from the socket and the master disconnect (power) switch must be turned off when the crane is not in use! Leaving the receiver connected and the power on when not in use may result in dangerous, unintentional activation of the crane functions.

For safety reasons the receiver will only function when it recognizes coded transmissions which match that of the intended transmitter. In the event that the receiver fails to recognize commands from the intended transmitter or when initially using a replacement transmitter the receiver must "learn" the transmission code of the transmitter. "Learning" a new transmission code is accomplished by depressing any button on the transmitter then depressing the "learn" button on the receiver, next to the antenna, until the light on the receiver begins to flash. Once the receiver light begins to flash release the learn button and then the transmitter button. The receiver will now recognize transmissions from the "learned" transmitter.

The transmitter is powered by a single 9V alkaline battery which may be replaced by removing the 4 screws from the transmitter housing and separating the 2 halves. Be sure to carefully align the two housing halves when reassembling the transmitter.



MFG., INC.
CINCINNATI, OHIO

TITLE

INSTALLATION DWG.

DATE

7-25-03A

SECTION

C200

RADIO REMOTE CONTROL

SUPERCEDES

2-11-03

20416

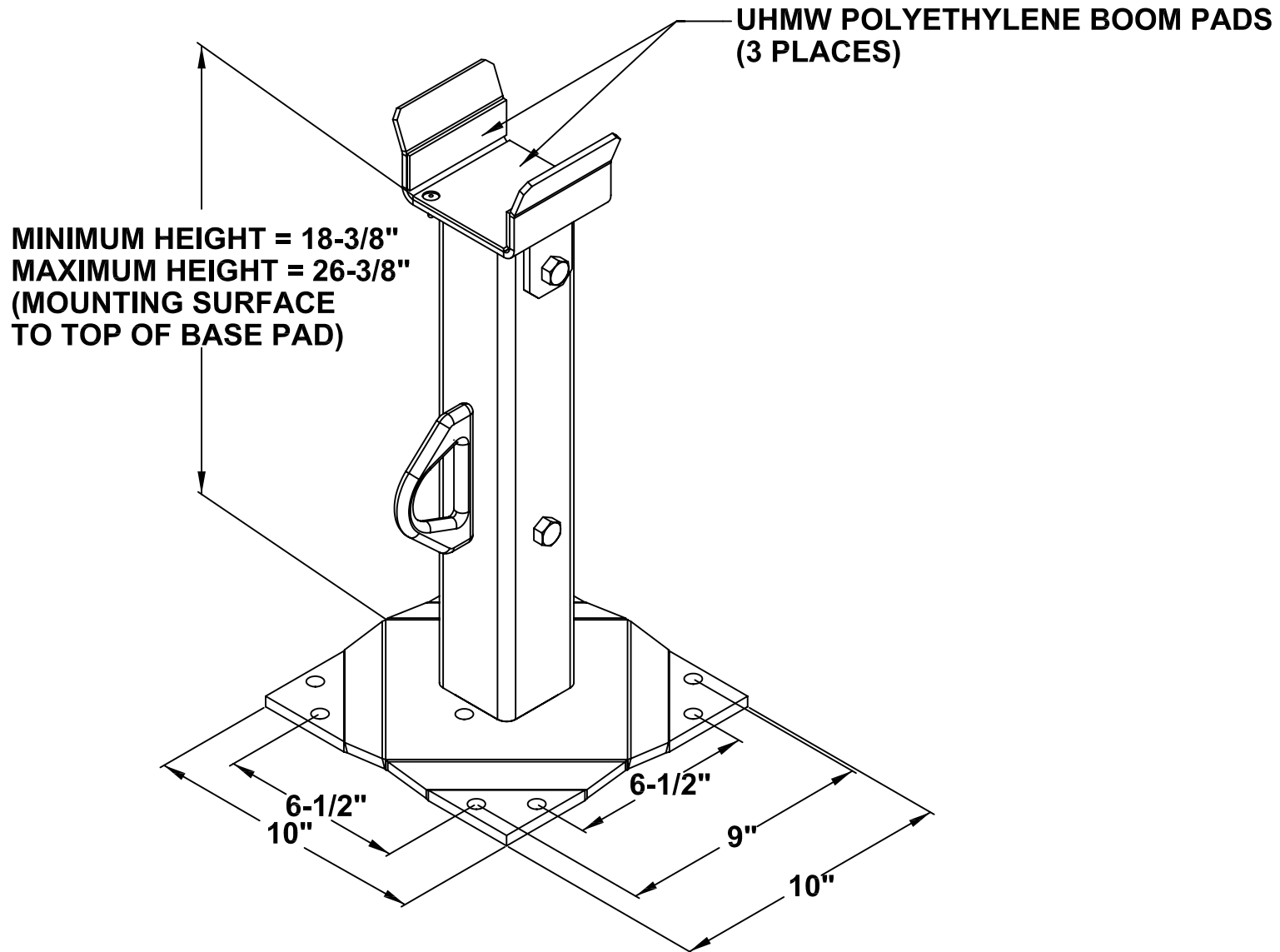

MANUFACTURING, INC.
CINCINNATI, OHIO

TITLE

INSTALLATION DRAWING

DATE

1-13-05A

SECTION

-

20075 ADJ BOOM REST - ET6KR, ET10K(X)

SUPERSEDES

5-7-01

20076



MINIMUM VOLTAGE TEST

ET5500, ET6K(M/R), ET8100, ET10K(X)

ONE OF THE MOST COMMON ELECTRICAL PROBLEMS ENCOUNTERED ON ELECTRICAL CRANES IS INSUFFICIENT VOLTAGE AT THE MOTOR WHEN DRAWING THE LARGE CURRENT THAT EXISTS AT FULL LOAD

TO ISOLATE THIS PROBLEM PERFORM THE MINIMUM VOLTAGE TEST BELOW:

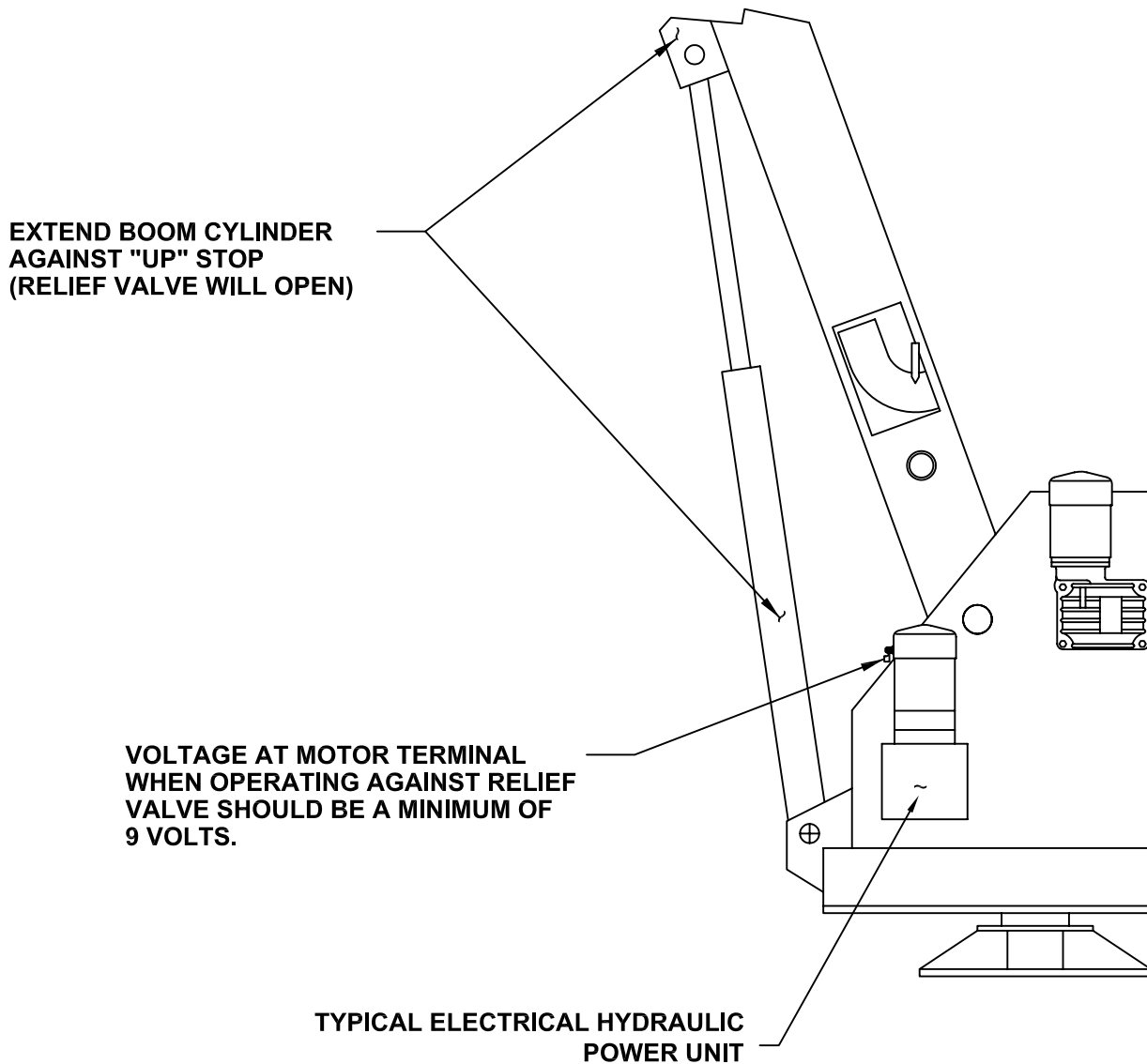



REPLACEMENT PARTS LIST REF 19289
REPLACEMENT FASTENERS LIST REF 19301

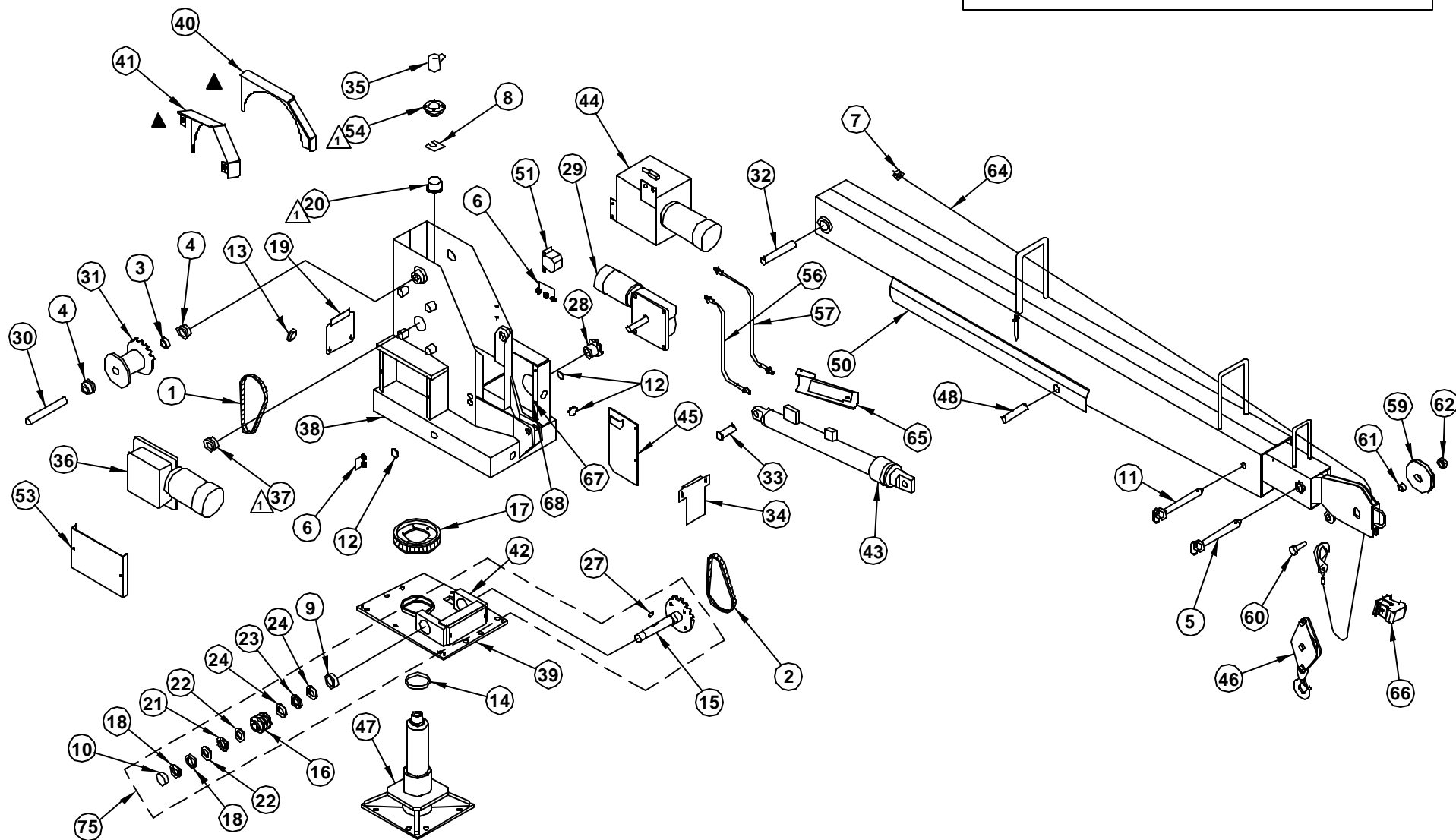

▲ INSTALL WITH LOCKTITE
GRADE 242 (BLUE) OR EQUIV.

FOR ELECTRICAL COMPONENTS
SEE DWG 17381



MANUFACTURING, INC.
CINCINNATI, OHIO

TITLE
REPLACEMENT PARTS

ET10K

DATE
8-30-04H

SUPERSEDES
9-3-03G

SECTION
C400

19363



ITEM #	PART #	DESCRIPTION	ITEM #	PART #	DESCRIPTION
1	00867-3	DRIVE CHAIN - WINCH (#40 x 56 LINKS)	41	20953	WINCHDRUM GUARD - RH
2	00867-4	DRIVE CHAIN - ROTATION (#40 x 52 LINKS)	42	18846	WORMHOUSING
3	01158	SHAFT COLLAR - 1"	43	17255-3	ELEVATION CYLINDER (ONLY)
4	01299	BALL BEARING - 2" OD x 1" ID	44	17260-1-RM	HYDRAULIC POWER UNIT (ONLY)
5	19258-3	BOOM PIN ASSEMBLY (SHORT)	45	17287	ROTATION CHAIN COVER
6*	14883	GROMMET - 3/8" ID x 5/8" OD W/ 3/16" GROOVE	46	20670	SWIVEL SNATCH BLOCK ASSEMBLY
7	13463-1	SHAFT COLLAR - 1/4"	47	17295	QUILL ASSEMBLY
8*	14159	SHIM - 1 1/2" SQ x .015", .042", .105"	48	17318	PIVOT PIN, CYL ROD
9	14341-3	BUSHING - 1 3/4" OD x 1 1/2" ID x 1" LONG	49	-	-
10	14341-5	BUSHING - 1 3/4" OD x 1 1/4" ID x 1" LONG	50	17800	BOOM ASSEMBLY (COMPLETE ASSY)
11	19258-2	BOOM PIN ASSEMBLY (LONG)	51	17356	OVERLOAD ALARM (OPTIONAL)
12	RL-644	HOLE PLUG - 1"	52	17150-20	PENDANT ASSEMBLY - 3 SWITCH x 20 FOOT CORD
13	RL-644	HOLE PLUG - 1"	53	17367	SIDE COVER
14	20189	LOWER BEARING - 5" OD x 1" LONG	54	17372	UPPER BEARING HOUSING
15	18860	SPROCKET & SHAFT ASSY	55	-	-
16	15650	WORM	56	19693	HOSE, ELEVATION CYL RETURN - 36" LONG
17	15651	WORM GEAR	57	17395	HOSE, ELEVATION CYL PRESSURE - 34" LONG
18*	15675	SHIM - 1 1/4" ID x .015", .031"	58	-	-
19	15676	REAR COVER	59	20537	POLY CABLE SHEAVE WITH BEARING
20	15681	UPPER BEARING	60	17059-4	SHEAVE AXLE
21	15696	NEEDLE THRUST BEARING	61	20536	SPACER - 20537 SHEAVE
22	15697	THRUST RACE	62	!JNUT-07510N	JAM LOCK NUT - 3/4"-10 NYLON
23	15698	NEEDLE THRUST BEARING	63	-	-
24	15699	THRUST RACE	64	15810-7/32-65	WIRE ROPE ASSY - 7/32" x 65 FT
25	-	-	65	19164	COVER - ELEVATION CYLINDER
26	-	-	66	16735	HEADACHE BALL ASSY (INCLUDES HARDWARE)
27*	15929	WOODRUFF KEY - 1/4" x 1 1/4"	67	20083	NUT BAR ROTATION P.U. - GROUNDING
28	15999	SPROCKET - #40 x 10 TOOTH	68	15664	NUT BAR - ROTATION P.U.
29	16107	ROTATION POWER UNIT	69	-	-
30	16614	WINCHDRUM SHAFT	70	-	-
31	16822	WINCHDRUM	71	17824	FIELD SERVICE LABEL KIT - ET10K W/ 7 - 15 FT BOOM
32	16825	PIVOT PIN, BOOM	72	-	-
33	16828	PIVOT PIN, CYL TAIL - 1" DIA x 2 3/4" LONG	73	-	-
34	16829	FRONT COVER	74	-	-
35*	17011	BOOT, SWIVEL TERMINAL	75	▲ 18845-FULL ASSY	WORM HOUSING ASSY (ALL ITEMS PRE-ASSEMBLED)
36	17211	WINCH POWER UNIT	76	-	-
37	17218	SPROCKET - #40 x 12 TOOTH	77	-	-
38	18870	WELDED HOUSING ASSY	78	-	-
39	18856	LWR B.P. ASSY	79	-	-
40	20957	WINCHDRUM GUARD - LH	80	-	-
		REPLACEMENT PARTS DWG REF 19363	*	15828	SMALL PARTS KIT (INCLUDES * ITEMS)



MANUFACTURING, INC.
CINCINNATI, OHIO

TITLE
REPLACEMENT PARTS

DATE
8-30-04N

SECTION
C400

ET10K-7/15

SUPERCEDES
9-3-03M

19289

**FASTENER LIST FOR INSTALLATION DRAWING ET10K-7/15**

PART NUMBER	DESCRIPTION	QTY	LOCATION/FUNCTION
!HHCS05013150	HHCS - 1/2"-13 x 1-1/2"	10	BASE PLATE
!LWSH-050	LOCK WASHER - 1/2"	10	BASE PLATE
18873	CAPSCREW - MODIFIED	6	WORM GEAR/QUILL HUB
!LWSH-038-HC	LOCK WASHER - 3/8" HI COLLAR	6	BULL GEAR 15651
!HHCS03816200TB	HHCS - 3/8"-16 x 2" TAP BOLT	1	ADJ FOR ROTAMOTOR
!HNUT-03816	HEX NUT - 3/8"-16, PLATED	1	ADJ FOR ROTAMOTOR
!HHCS03118250	HHCS - 5/16"-18 x 2-1/2"	1	BOOMPIN
-	-	-	-
!LNUT-03118	LOCKNUT - 5/16"-18	1	BOOMPIN
!HHCS03816150	HHCS - 3/8"-16 x 1-1/2"	3	WINCH POWER UNIT
!HHCS03816300	HHCS - 3/8"-16 x 3"	1	WINCH POWER UNIT
▲ !LWSH-038-STAR	LOCK WASHER - 3/8" - STAR	4	WINCH POWER UNIT
!HHCS03816125	HHCS - 3/8"-16 x 1-1/4"	1	ROTATION MOTOR
!HHCS03816150	HHCS - 3/8"-16 x 1-1/2"	2	ROTATION MOTOR
!HHCS03816300	HHCS - 3/8"-16 x 3"	1	ROTATION MOTOR
▲ !LWSH-038-STAR	LOCK WASHER - 3/8" - STAR	4	ROTATION MOTOR
!LWSH-031	LOCK WASHER - 5/16"	2	HYDRAULIC MOTOR
!HHCS03816225-5	HHCS - 3/8"-16 x 2-1/4"	2	HYDRAULIC MOTOR
!HHCS03118075	HHCS - 5/16"-18 x 3/4"	2	HYDRAULIC MOTOR
!LWSH-038	LOCK WASHER - 3/8"	2	HYDRAULIC MOTOR
!HHCS03816125	HHCS - 3/8"-16 x 1-1/4"	4	UPPER BEARING HOUSING
!LWSH-038	LOCK WASHER - 3/8"	4	UPPER BEARING HOUSING
!HHCS02520063-5	HHCS - 1/4"-20 x 5/8"	8	CHAIN GAURD - WINCH DRUM
!LWSH-025	LOCK WASHER - 1/4"	8	CHAIN GAURD - WINCH DRUM
!HNUT-02520	HEX NUT - 1/4"-20	6	CHAIN GAURD - WINCH DRUM
!LWSH-#10	LOCK WASHER - #10	2	WIRING
!HWHS02520063-F	HEX WASHER HEAD - 1/4"-20 x 5/8"	14	COVERS & WIRING
!PHCS02520075	PHCS - 1/4"-20 x 3/4", SLOTTED	8	WIRING
!LWSH-025	LOCK WASHER - 1/4"	8	WIRING
!HNUT-02520	HEX NUT - 1/4"-20	8	CONTACTORS
!PHCS-#1024050	PHCS - 10-24 x 1/2"	2	CIRCUIT BREAKER
!UNUT15195-1420	U-NUT - 1/4"-20	2	VOLTAGE STABILIZER
!UNUT-#1024	U-NUT - #10-24 x 3/8"	2	CIRCUIT BREAKER
!FWSH-038	FLAT WASHER - 3/8"	4	CRATING
!CHCS03118400	CARRIAGE BOLT - 5/16-18 x 4"	4	CRATING
!FWSH-031	FLAT WASHER - 5/16"	4	CRATING
!HNUT-03118	HEX NUT - 5/16"-18	4	CRATING
!LWSH-#10	LOCK WASHER - #10	2	CIRCUIT BREAKER
!RPIN-025100	ROLL PIN - 1/4" x 1"	1	CYLINDER PIN
!RPIN-025175	ROLL PIN - 1/4" x 1-3/4"	1	CYLINDER PIN
!RPIN-038100	ROLL PIN - 3/8" x 1"	4	BASE PLATE
!SHCS05013125	SHCS - 1/2"-13 x 1-1/4"	4	ADJ BEARING PLATE
!LWSH-050	LOCK WASHER - 1/2"	4	ADJ BEARING PLATE
!SHCS03824150	SHCS - 3/8"-24UNF x 1-1/2"	2	WORM BLOCK FORE/AFT
!SHCS03824100KC	SET SCREW - 3/8"-24 x 1"	2	WORM BLOCK FORE/AFT
25593	SET SCREW - FLAT FACE - 1/2"-20 x 1"	1	WORM BLOCK LEFT/RIGHT SECURE
!HWHS02520038-F	HEX WASHER HEAD - 1/4"-20 x 3/8"	4	LOWER COVERS
!HNUT-#1032	HEX NUT - #10-32	2	CIRCUIT BREAKER
!LWSH-#10	LOCK WASHER - #10	2	CIRCUIT BREAKER
!SHCS03816050KC	SET SCREW - 3/8"-16 x 1/2"	2	WORM - ROTATION
!ZERK02528	ZERKLUBE FITTING - 1/4"-28	2	-
-	-	-	-
-	-	-	-
-	-	-	-
-	-	-	-

REPLACEMENT PARTS DWG REF 19363



TITLE	DATE	SECTION
REPL. FASTENERS LIST	10-11-04E	C400
ET10K	SUPERCEDES 5-1-01D	19301



▲	24	2	20951-1	HANGER CABLE				
	23	1	!HHCS02520150	HEX HEAD CAP SCREW - 1/4-20 x 1 1/2"	11	1	19302	SET COLLAR
	22	1	19588	WIRE HARNESS	10	4	!LWSH-031	LOCK WASHER - 5/16"
	21	1	19587	WIRE HARNESS	9	4	!HHCS03118050-5	HEX HEAD CAP SCREW - 5/16-18 x 1/2"
	20	1	!LWSH-025	LOCK WASHER - 1/4"	8	1	19275	CABLE CLAMP - 3/4" x 13/32" HOLE
	19	1	22490	SPACER - BOOM ARROW	7	2	19270	SNAP BUSHING - 3/8" I.D.
	18	2	!HNUT-02520	HEX NUT - 1/4-20	6	1	19063	SNAP BUSHING - 1/2" I.D.
	17	1	!HHCS02520100-5	HEX HEAD CAP SCREW - 1/4-20 x 1" GR. 5	5	1	19058	COVER - CORD REEL
	16	3	!HHCS02520175	HEX HEAD CAP SCREW - 1/4-20 x 1 3/4"	4	1	19855	SWITCH BRACKET
	15	2	!LWSH-#06	LOCK WASHER - #6	3	1	19377-1	CABLE WEIGHT ASSY
	14	2	!FWSH-#06	FLAT WASHER - #6	2	1	22388-1	CORD REEL ASSY
	13	2	!HNUT-#0632	HEX NUT - #6-32	1	1	19376	LIMIT SWITCH
	12	2	!PHMS#632125	PAN HEAD MACHINE SCREW - #6-32 x 1 1/4"	ITEM	QTY	PART NO.	DESCRIPTION



MANUFACTURING, INC.
CINCINNATI, OHIO

TITLE

REPLACEMENT PARTS DWG

DATE

12-18-02C

SECTION

C400

19197-3 ANTI-TWO-BLOCK SYSTEM

SUPERSEDES

8-26-02B

20197-3

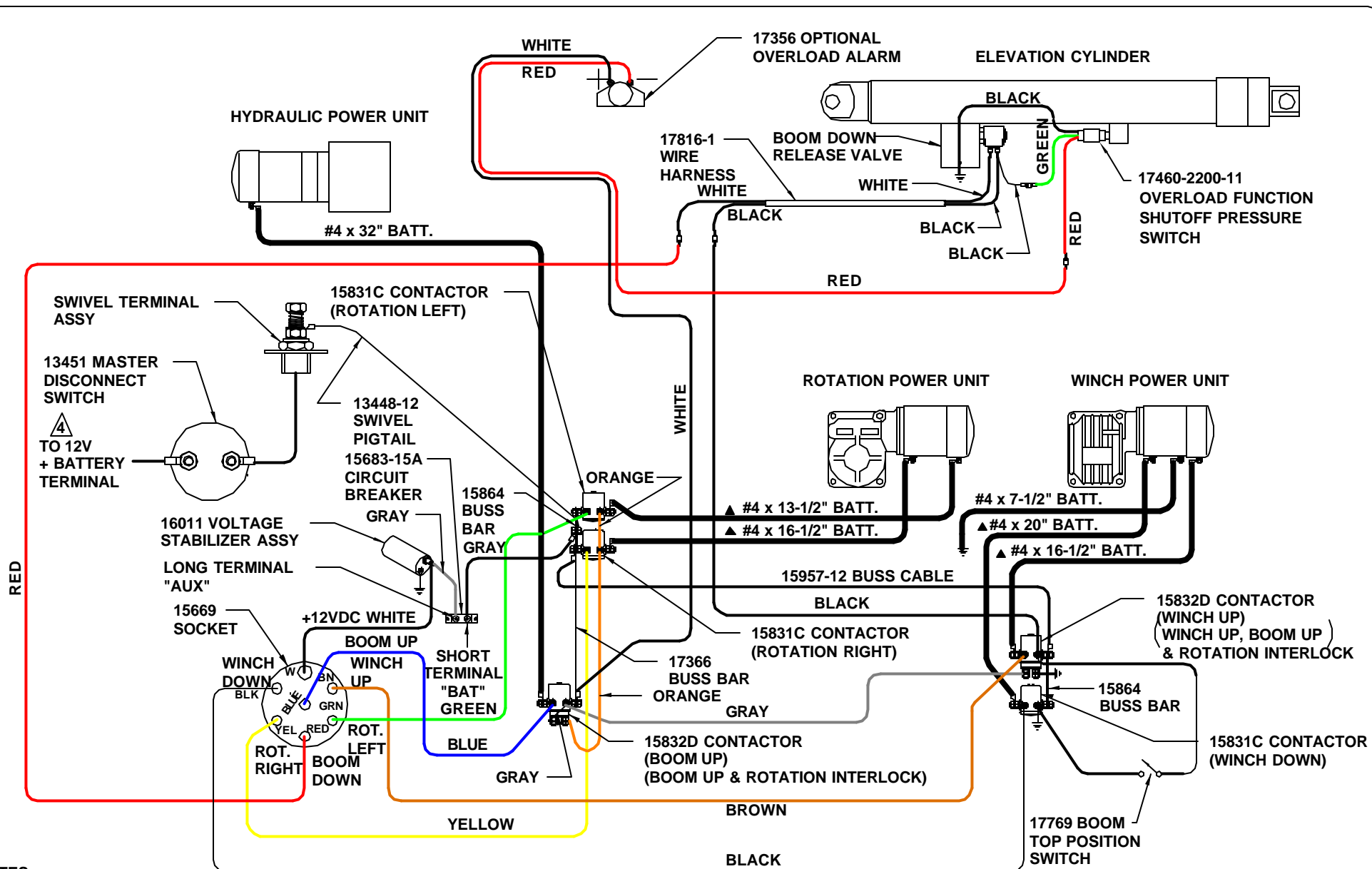

NOTES:
 1. SEE DWG 19791 FOR PENDANT CONTROL ASSY.
 2. SEE DWG 17817 FOR CONTROL WIRE SET.
 3. SEE DWG 17375 FOR BATTERY CABLE KIT.
 ▲ THIS CRANE OPERATES ON NEGATIVE GROUND SYSTEM ONLY.



TITLE
WIRING DIAGRAM

ET10K

DATE
9-8-04A

SUPERSEDES
7-1-02

SECTION
C400

20592

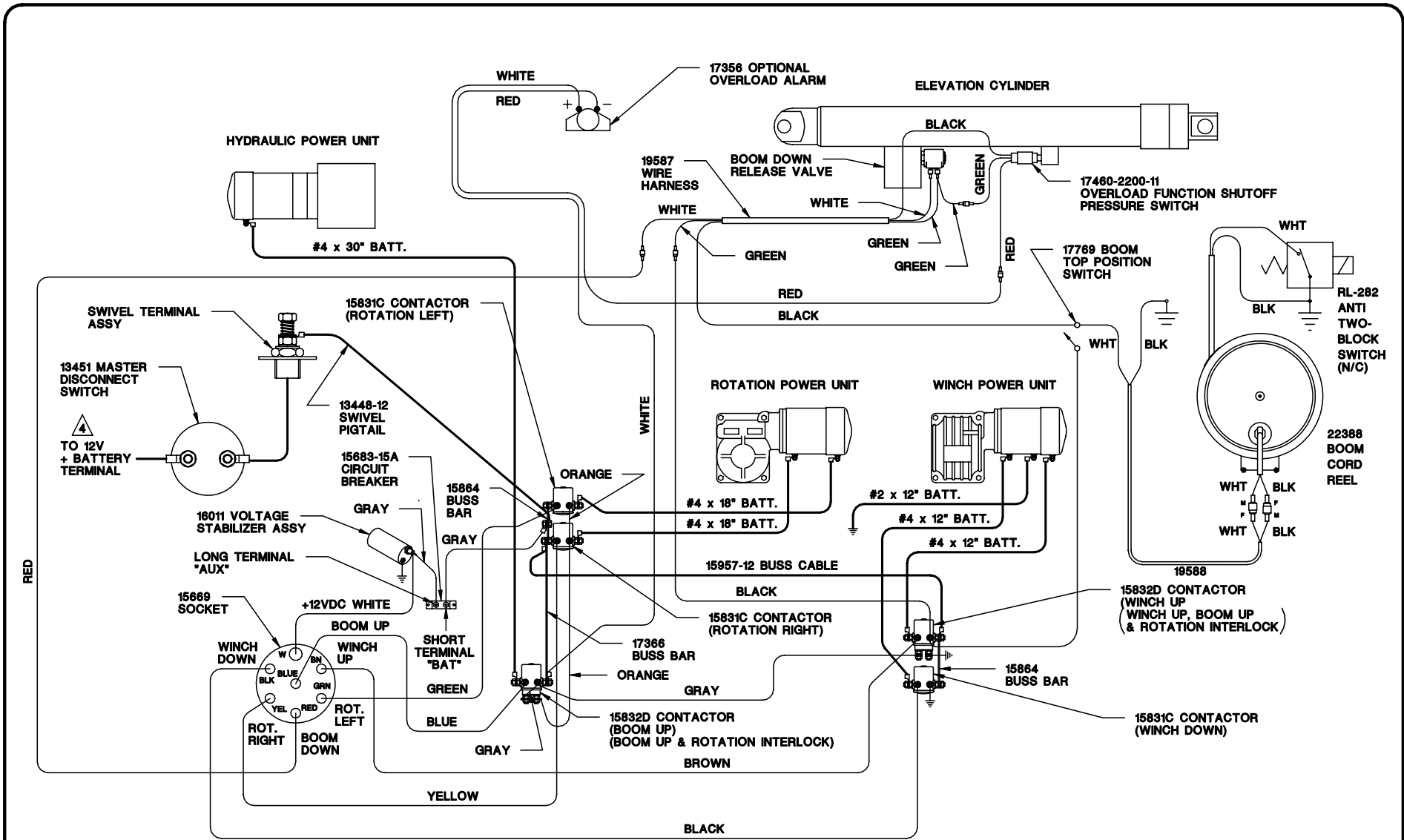

NOTES:

1. SEE DWG 19314 FOR PENDANT CONTROL ASSY.
 2. SEE DWG 17817 FOR CONTROL WIRE SET.
 3. SEE DWG 17375 FOR BATTERY CABLE KIT.
- ⚠ THIS CRANE OPERATES ON NEGATIVE GROUND SYSTEM ONLY.



TITLE
WIRING DIAGRAM

ET10K WITH ANTI-2-BLOCK

DATE
7-1-02

SUPERSEDES
-

SECTION
C400

20593

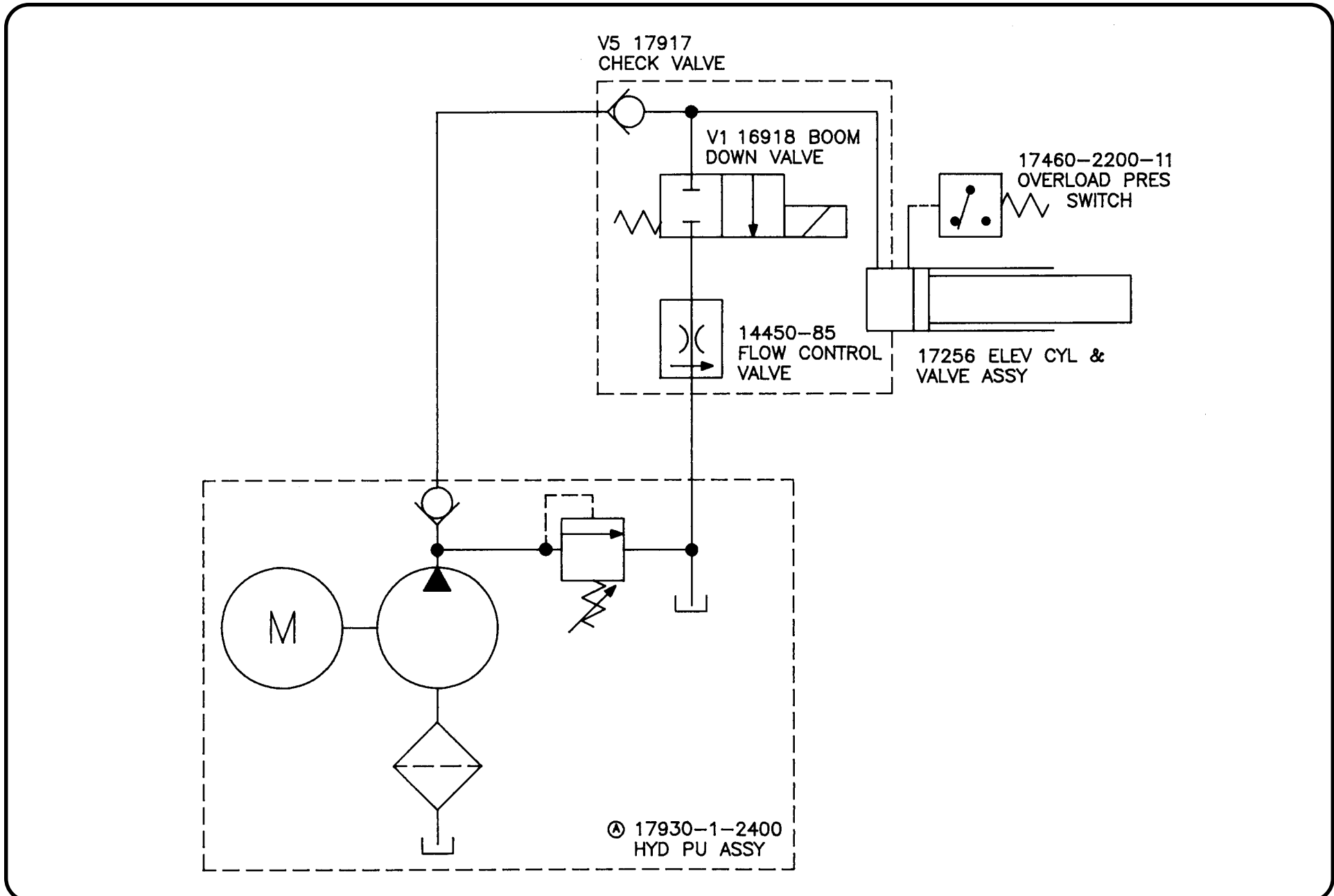

VENTURO MANUFACTURING, INC.
CINCINNATI, OHIO

TITLE
HYDRAULIC SYSTEM DIAGRAM
ET10K

DATE
6-19-98B

SUPERCEDES
11-20-91A

SECTION
C400

17935



19790 3-SWITCH PENDANT

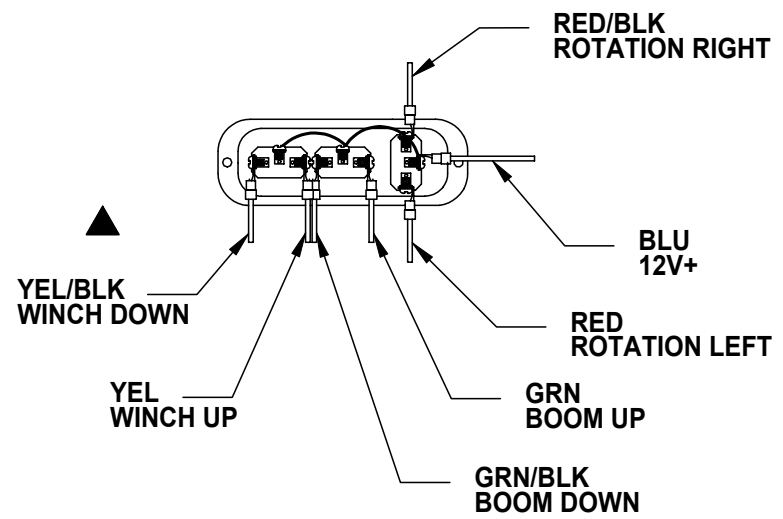
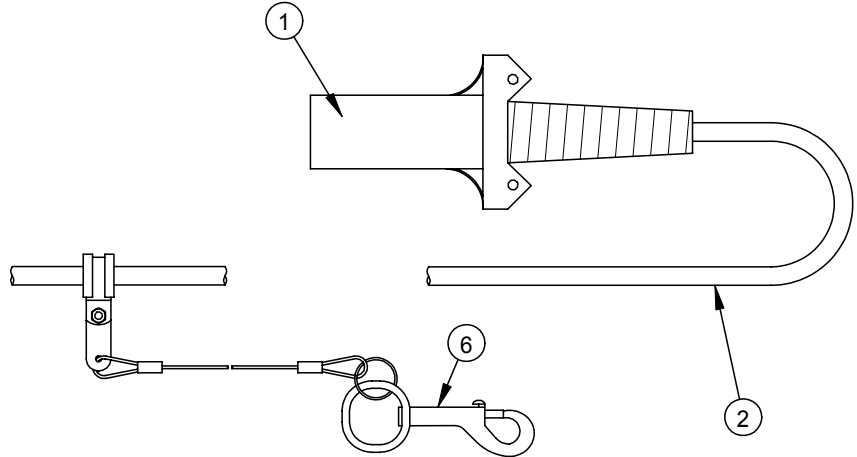
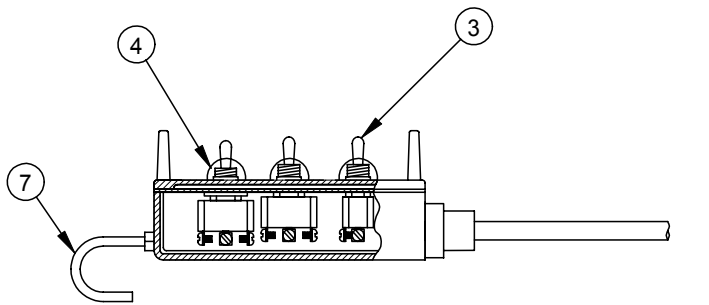
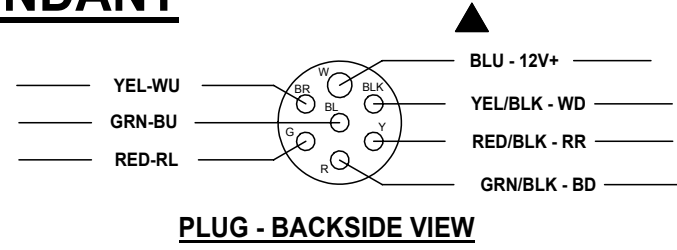
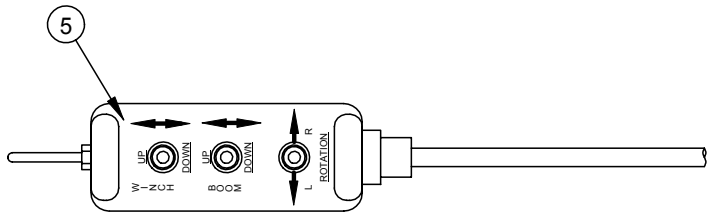

ITEM	QTY	PART NO.	DESCRIPTION
7	1	11557	PENDANT HOOK
6	1	15913-2	PHAN, CLAMP AND TETHER ASSY
5	1	25538	DECAL
4	3	19793	TOGGLE BOOT
3	3	13763	TOGGLE SWITCH
2	1	17151-xx	CORD ASSY (xx = LENGTH IN FT.)
1	1	24348	PLUG - 7 POLE



TITLE	DATE	SECTION
REPL. PARTS DWG.	10-18-01B	C400
3 FUNCTION CRANES	SUPERSEDES 4-10-00A	19791



20414 RADIO REMOTE

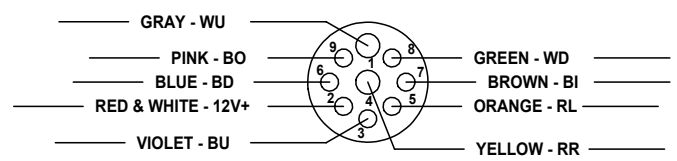
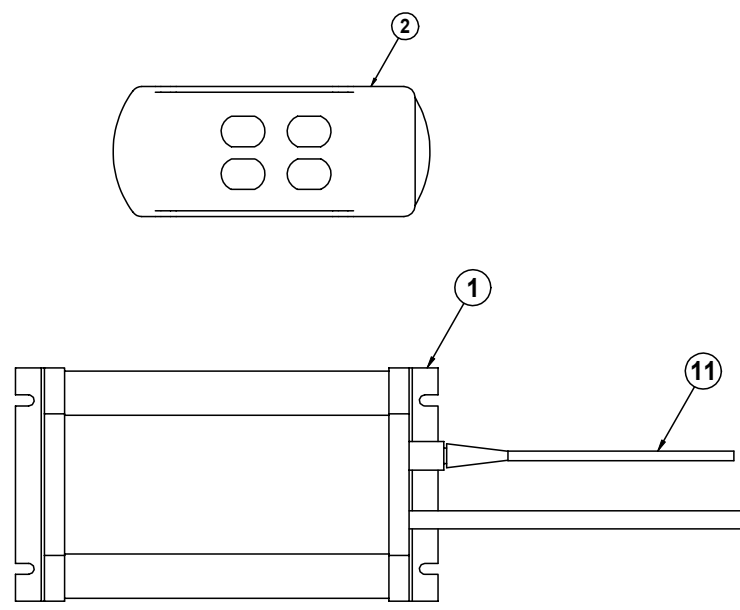

PLUG - BACKSIDE VIEW

BLACK & TAN WIRES - CUT & INSULATE W/ HEAT SHRINK TUBE INSIDE PLUG HOUSING

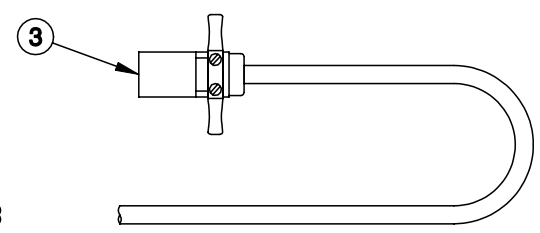

LENGTH = 20" MIN.



NOTE: ANTENNA IS SUPPLIED WITH RADIO, ALSO AVAILABLE AS A REPLACEMENT PART

ITEM	QTY	PART NO.	DESCRIPTION
▲ 11	1	20966	ANTENNA (SEE NOTE)
▲ 10	1	20965	REMOTE ANTENNA ASSEMBLY (OPTIONAL)
9	9	!TERM16G-PIN	16GA PIN TERMINAL (NOT SHOWN)
8	4	!HNUT-#1024	HEX NUT - #10-24 (NOT SHOWN)
7	2	!LWSH-#10-STAR	LOCK WASHERS - STAR (NOT SHOWN)
6	3	!LWSH-#10	#10 LOCK WASHERS (NOT SHOWN)
5	8	!FWSH-#10	#10 FLAT WASHERS (NOT SHOWN)
4	4	!PHCS-#10075	PAN HEAD CAP SCREWS - #10-24 - (NOT SHOWN)
3	1	26263	PLUG - 9 POLE
2	1	20413-TX	REMTRON RADIO TRANSMITTER
1	1	20413-RX	REMTRON RADIO RECEIVER



TITLE	DATE	SECTION
REPLACEMENT PARTS DRAWING	7-2-03A	-
ET10K(X)	SUPERSEDES	20947
	3-19-03	



16770 SWIVEL TERMINAL ASSY

15666 ¹/₂

13450-13.5 ³

17011 RUBBER BOOT - REF

13448-XX SWIVEL PIGTAIL
(NO INCLUDED WITH 16770)

ITEM	QTY	PART NO.	DESCRIPTION
1	1	15653-60	PIGTAIL & STUD ASSY
2	1	13447-13.5	PIGTAIL & STUD ASSY
*3	3	16771-1	FIBER WASHER 1/2" I.D. x 15/16" O.D. x 1/16" THK
*4	1	13410	INSULATING BUSHING
5	1	13467	3/4" INVERTED FLARE NUT - MODIFIED
6	1	!FWSH-100SAE	FLAT WASHER 1 1/8" I.D. x 2 1/8" O.D. x 1/8" THK
*7	1	16771-2	FIBER WASHER 1/2" I.D. x 1 1/4" O.D. x 1/16" THK
*8	1	16770*7	BRASS WASHER 1/2" I.D. x 1 1/4" O.D. x 5/64" THK
*9	1	19800 ▲	BRASS JAM NUT - 1/2"-13NC - MODIFIED ▲
*10	1	16770*11	TEFLON WASHER 1/2" I.D. x 3/4" O.D. x 1/32" THK
*11	1	16770*10	BRASS WASHER 1/2" I.D. x 11/16" O.D. x 1/32" THK
*12	1	LC-063HJ-1	SPRING .66" O.D. x .63" W x 5/8" F.L.
*13	1	!JNUT-05013N	NYLON INSERT-JAMNUT - 1/2"-13
*14	1	12534-4	MACHINERY BUSHING 1/2" I.D. x 7/8" O.D. x 14 GA THK
*15	1	LOCTITE-24205	LOCTITE CAPSULE GRADE 242 BLUE
*16	1	16770	REPL. PARTS DWG (THIS PAGE)

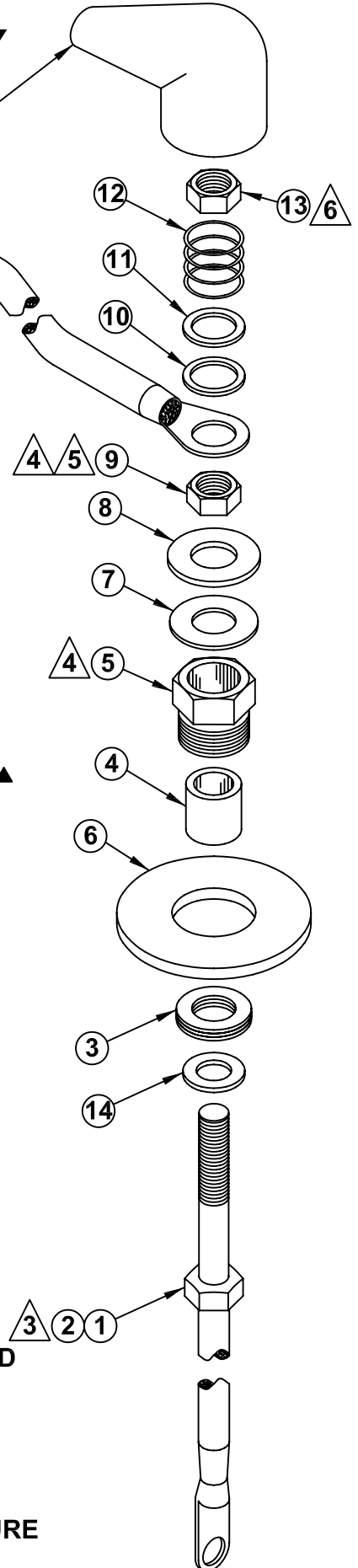

* ITEMS ARE ONLY AVAILABLE IN A 16772 SERVICE PARTS KIT

- ¹ 16772 SERVICE PARTS KIT CONVERTS 15666 TO 16770
- ² 16770 REPLACES & IS INTERCHANGEABLE WITH 15666
- ³ 13447-13.5 PIGTAIL STUD ASSY REQ'D WITH 13450-13.5 ASSY USED ON EARLY MODEL ET5500M/(PB) CRANES
- ⁴ SECURE WITH LOCTITE 242 BLUE
- ⁵ TORQUE TO 30 FT-LBS, THEN TIGHTEN SET SCREW. ▲
- ⁶ TIGHTEN UNTIL ONE THREAD IS VISIBLE ABOVE THE NUT & ENSURE THAT SPRING IS NOT FULLY COMPRESSED

MFG., INC.
CINCINNATI, OHIOTITLE
REPLACEMENT PARTSET5500, ET6KM/R,
ET8100, ET10K(X)DATE
1-14-05GSUPERSEDES
2-21-02FSECTION
C455**16770**



17211 WINCH POWER UNIT

SERVICE INSTRUCTIONS	
24499-8	ASSY & SERVICE INSTRUCTIONS
24499-1	INSTRUCTIONS

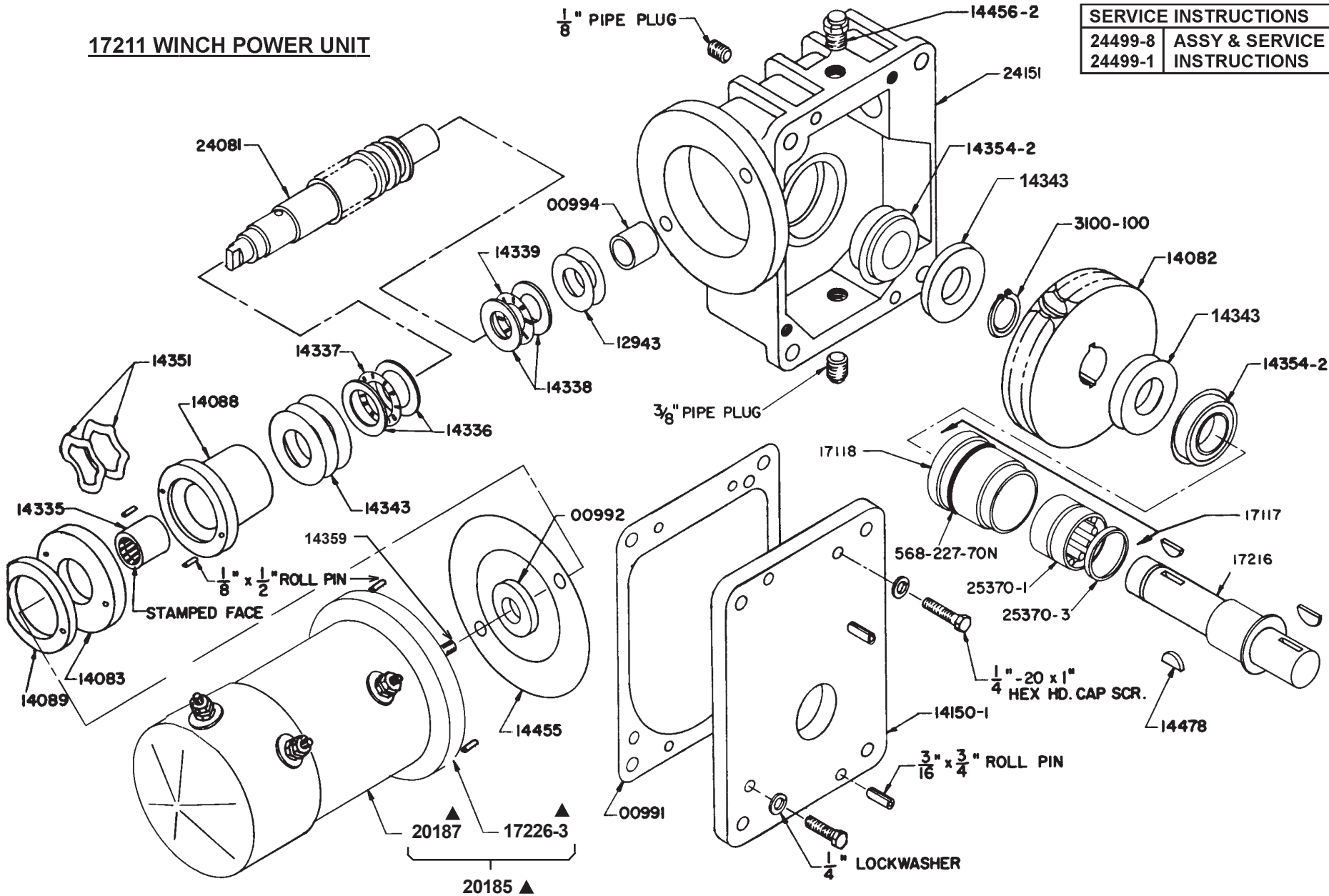

VENTURO MANUFACTURING, INC.
CINCINNATI, OHIO

TITLE	DATE	SECTION
REPLACEMENT PARTS	3-5-03B	C400
ET10K(X)	SUPERCEDES 2-4-03A	20493

**REPLACEMENT PARTS LIST - 17211 WINCH POWER UNIT**

MODEL: ET10K(X)

PART NO.	DESCRIPTION
* 00991 * 00992 00994 * 12943-1 * 12943-2	GASKET SEAL WORMSHAFT BUSHING SHIM WASHER - 3/4" x 1 1/2" x .005" (AS REQUIRED) SHIM WASHER - 3/4" x 1 1/2" x .015" (AS REQUIRED)
* 12943-3 14082 14083 14088 14089	SHIM WASHER - 3/4" x 1 1/2" x .030" (AS REQUIRED) WORM GEAR BRAKE MOTOR CLUTCH HOUSING (INCLUDES 1/8" x 1/2" ROLL PIN) BRAKE DISC
14150-1 14335 14336 14337 14338	COVER ROLLER CLUTCH THRUST RACE - 1" NEEDLE THRUST BEARING - 1" I.D. THRUST RACE - 3/4"
14339 * 14343-1 * 14343-2 * 14343-4 * 14345-1	NEEDLE THRUST BEARING - 3/4" I.D. SHIM WASHER - 1" x 1 1/2" x .005" (AS REQUIRED) SHIM WASHER - 1" x 1 1/2" x .015" (AS REQUIRED) SHIM WASHER - 1" x 1 1/2" x .031" (AS REQUIRED) SHIM WASHER - 1" x 2" x .005" (AS REQUIRED)
* 14345-2 * 14351 14354-2 * 14455 14456-2 * 14478	SHIM WASHER - 1" x 2" x .015" (AS REQUIRED) WAVE WASHER BALL BEARING GASKET - MOTOR BREATHER CAP ASSEMBLY #91 WOODRUFF KEY - 1/4" x 3/4"
24081 24151 20185 ▲ 25370-1 * 25370-3 17117	WORM & SHAFT GEAR CASE MOTOR (INCLUDES 00992 SEAL) ROLLER BEARING (INCLUDES 25370-3 SEAL) SEAL BEARING & HOUSING ASSEMBLY (INCLUDES 25370-1, 25370-3, 17118 & 568-277-70N)
17216 17218 * 3100-100 * OR-227-7 * IRPIN-013050 * IRPIN-019075	SHAFT & RACE ASSEMBLY BEARING HOUSING RETAINING RING O-RING - 2 1/8" x 2 3/8" x 1/8" ROLL PIN - 1/8" x 1/2" ROLL PIN - 3/16" x 3/4"
16485 17468-1 17468-2 17468-3	SHIM, KEY, PIN & SEAL KIT (INCLUDES ITEMS MARKED *) MOTOR REPAIR KIT (INCLUDES 00992 SEAL & 14455 GASKET) FOR 17221-1 MOTOR MOTOR REPAIR KIT (INCLUDES 00992 SEAL & 14455 GASKET) FOR 17221-2 MOTOR MOTOR REPAIR KIT (INCLUDES 00992 SEAL & 14455 GASKET) FOR 16115 MOTOR

▲

MFG., INC.
CINCINNATI, OHIO

TITLE

REPL. PARTS LIST

DATE

6-20-03A

SECTION

C400

17211 WINCH PU

SUPERCEDES

1-8-02

20494



SERVICE BULLETINS	
14924	SHIM ADJUSTMENT
821214	MOTOR INSTALLATION

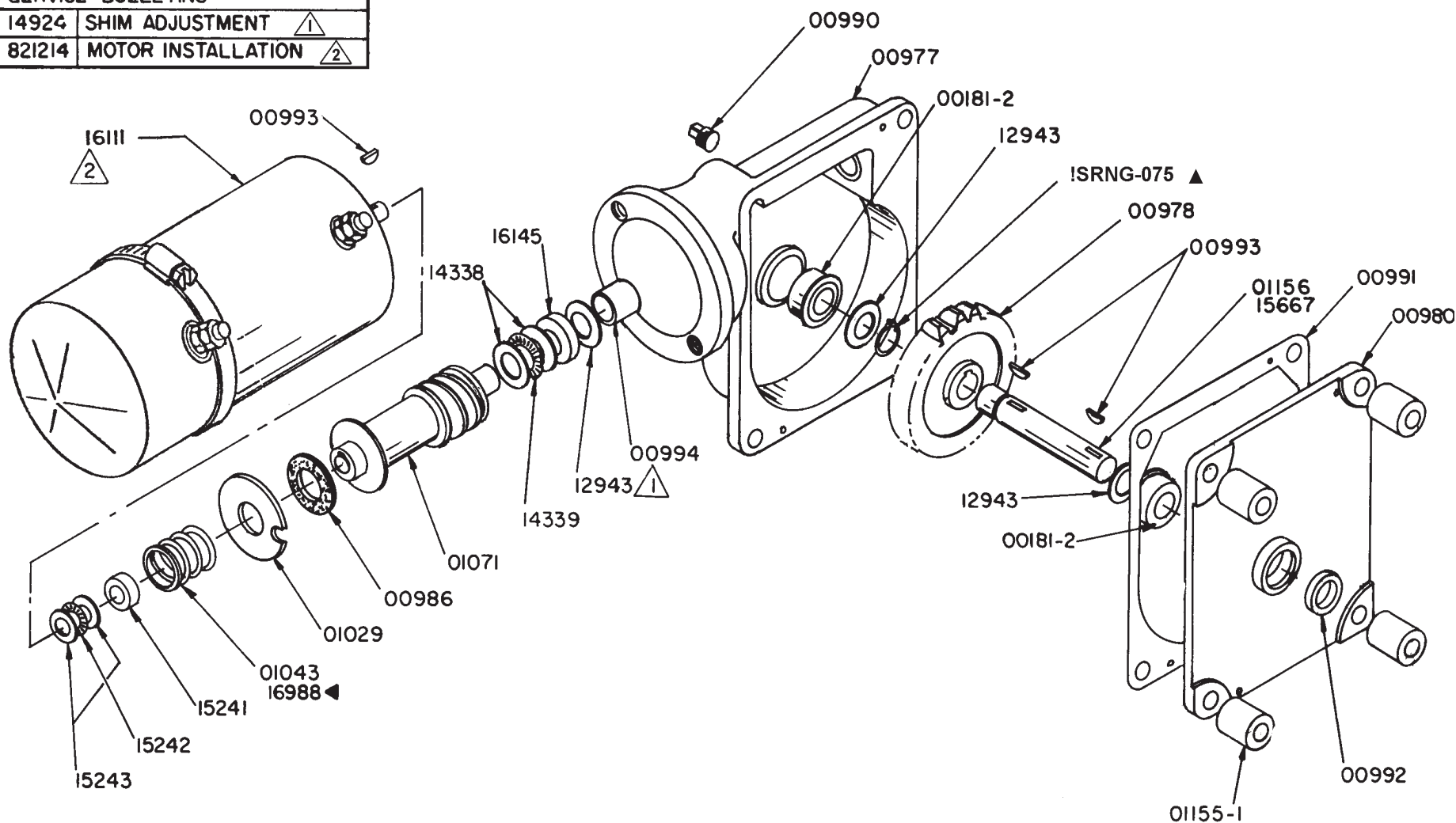

SEE DWG. 14924/14926 FOR SERVICE INSTRUCTION

16100 SERIES POWER UNITS



MANUFACTURING, INC.
CINCINNATI, OHIO

TITLE	DATE	SECTION
REPLACEMENT PARTS	4-14-04E	C450
WINCH & CRANE	SUPERCEDES 6-17-98D	116100

**REPLACEMENT PARTS LIST - 16100 ELECTRIC POWER UNIT**

MODEL(S): ET5500MPB, ET6KM, ET6KR

PART NO.	DESCRIPTION
16101 16102 16105 ▲ 16105-1 16106 16107	POWER UNIT - LONG SHAFT - ET5500R WINCH [△] POWER UNIT - SHORT SHAFT - ET5500R ROTATION POWER UNIT - LONG SHAFT - CA 2000, CT 2003, WA/SL 3000 (WITH SPACERS) POWER UNIT - LONG SHAFT - CA 2000, CT 2003/4/5(FB), WA/SL 3000 (WITHOUT SPACERS) POWER UNIT - LONG SHAFT [△] ▲ POWER UNIT - SHORT SHAFT - ET5500R ROTATION
00181-2 00977 00978 00980 * 00986	FLANGE BEARING - 3/4" BORE x 1 3/4" O.D. GEAR CASE (INCLUDES 00994 BUSHING) WORM GEAR BASE PLATE (00980-1) & INSERT (00980-2) ASSEMBLY ▲ BRAKE DISC
* ISRNG-075 00990 * 00991 * 00992 [△] * 00993	RETAINING RING - 3/4" OIL PLUG - 1/4" PIPE GASKET OIL SEAL KEY - #9 WOODRUFF
00994 01029 01043 [△] 01071 01155-1	BUSHING BRAKE PLATE BRAKE SPRING (16102 & 16107 ROTATION POWER UNIT ONLY) WORM SHAFT SPACER (16105 ONLY)
01156 * 12943-1 [△] * 12943-2 [△] * 12943-3 [△] 14338	WORM GEAR SHAFT - 3/4" x 5 3/16" LONG (16105 & 16106 ONLY) SHIM WASHER - .005" THICK (AS REQUIRED) SHIM WASHER - .015" THICK (AS REQUIRED) SHIM WASHER - .030" THICK (AS REQUIRED) NEEDLE THRUST RACE 3/4" I.D.
14339 15241 15242 15243 15667	NEEDLE THRUST BEARING 3/4" I.D. SPACER (INSTALL NEXT TO BRAKE PLATE) NEEDLE THRUST BEARING 5/8" I.D. NEEDLE THRUST RACE .092" x 5/8" I.D. WORM GEAR SHAFT - 3/4" x 4 3/16" LONG (16102 & 16107 ONLY)
16111 [△] 16145 16988 [△]	MOTOR - 12 VOLT 4 1/2" DIAMETER SPACER BRAKE SPRING (16101, 16105 & 16106 WINCH POWER UNITS ONLY)
14889 15290	MOTOR REPAIR KIT SMALL PARTS KIT (INCLUDES ITEMS MARKED *)

¹ AVAILABLE ONLY AS PART OF 15290 SMALL PARTS KIT² 16101 POWER UNIT REPLACED BY 16106 POWER UNIT
16102 POWER UNIT REPLACED BY 16107 POWER UNIT³ REPLACE 30E & 16100 POWER UNITS AS FOLLOWS:
16105 REPLACES 11497
16106 REPLACES 11497NS & 16101
16107 REPLACES 16102⁴ 16111 MOTOR REPLACES 01024 E & F & 16112 MOTORS
ON ALL 30E & 16100 SERIES POWER UNITS⁵ 16988 BRAKE SPRING REPLACES 01043 BRAKE SPRING ON
16101, 16105 & 16106 WINCH POWER UNITS ONLYMFG., INC.
CINCINNATI, OHIOTITLE
REPL. PARTS LIST**16100 ELECTRIC PU**DATE
12-6-04FSUPERCEDES
4-14-04ESECTION
C400**811016**

**REPLACEMENT PARTS LIST - 17930-1 HYDRAULIC POWER UNIT**

MODEL: ET10K

ITEM	PART NO.	DESCRIPTION
	17930-1	HYDRAULIC POWER UNIT ASSEMBLY
1	17260-1-2400	HYDRAULIC POWER UNIT
2	17293	RETURN TUBE ASSEMBLY
3	HRDB6MP-2FP	PIPE BUSHING 3/8" - 1/8" NPT
4	HELB2MP-2FX-90	SWIVEL ADAPTER
5	HTAD6MJ-4FP	STRAIGHT ADAPTER
6	HTEL6MJ-4MP-90	ELBOW TUBE ADAPTER

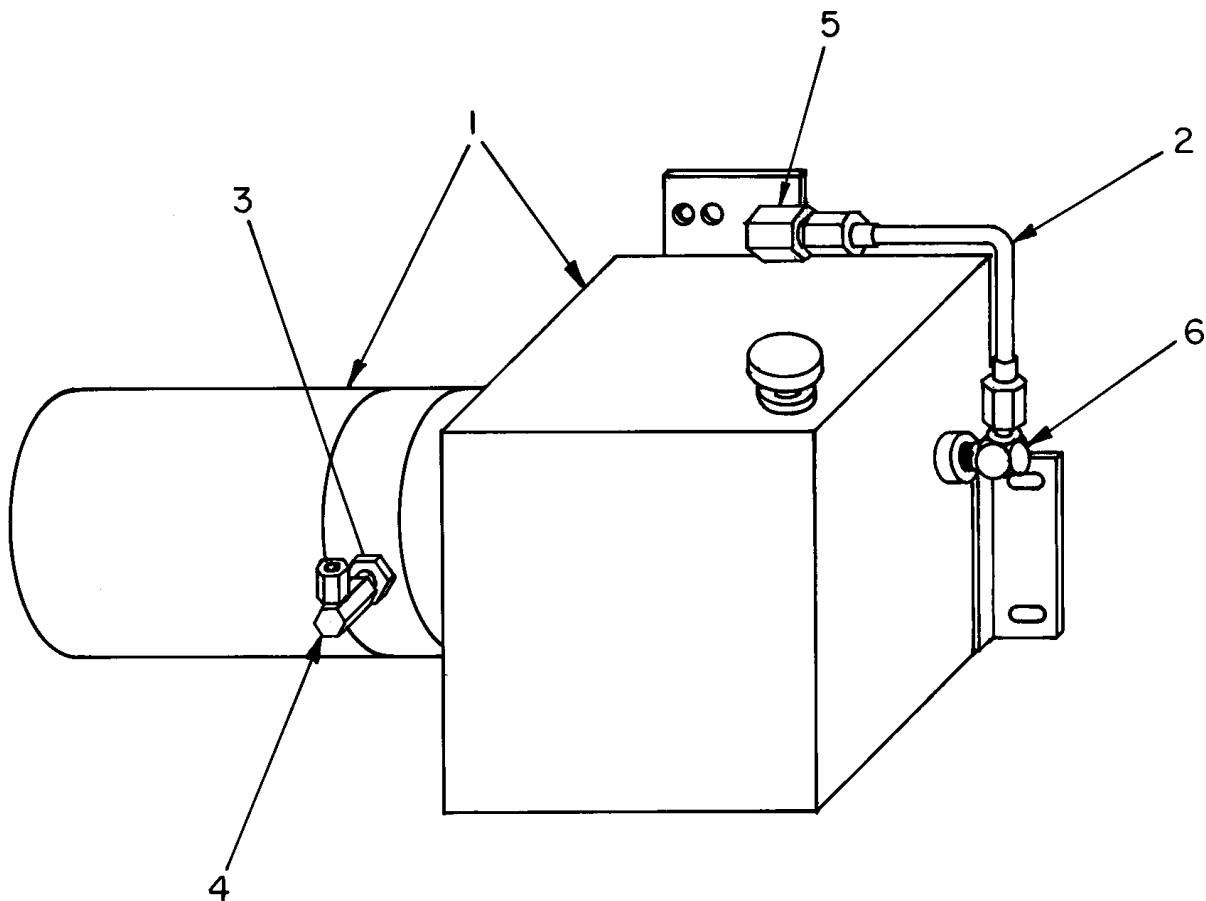

VENTURO MFG., INC.
CINCINNATI, OHIO

TITLE
REPLACEMENT PARTS
ET10K

DATE
6-19-98A
SUPERCEDES
6-7-91

SECTION
C400
I17930

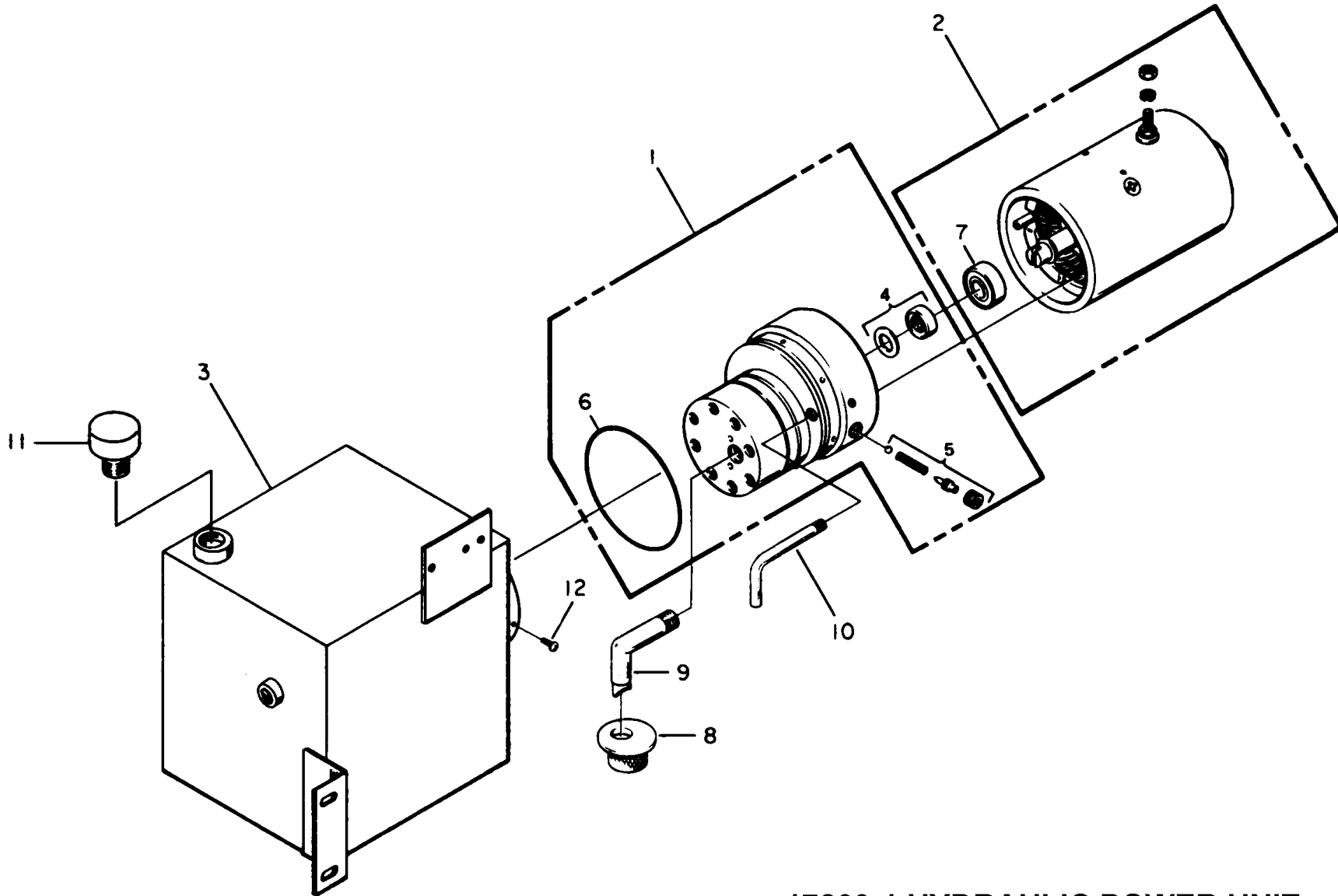

17260-1 HYDRAULIC POWER UNIT

VENTURO MANUFACTURING, INC.
CINCINNATI, OHIO

TITLE	DATE	SECTION
REPLACEMENT PARTS	6-19-98A	C400
ET10K(X)	SUPERCEDES 2-20-90	17451

**REPLACEMENT PARTS LIST - 17260-1 HYDRAULIC POWER UNIT**

MODEL: ET10K(X)

ITEM	PART NO.	DESCRIPTION
	17260-1-2400*	HYDRAULIC POWER UNIT
1	16943	PUMP ASSEMBLY
2	16940	MOTOR - 12V DC
3	17283	RESERVOIR ASSEMBLY
4	02330	SEAL & GASKET KIT
5	02220	RELIEF VALVE KIT
6	OR-239-7	O-RING (3 5/8" x 3 7/8" x 1/8")
7	02318	BALL BEARING
8	01134	SUCTION FILTER SCREEN
9	-	SUCTION TUBE
10	-	RETURN TUBE
11	19276	VENT PLUG (3/8" NPT)
12	07703	SCREW (10-24NC x 3/8")
-	17282	PACKING KIT

*STANDARD RELIEF VALVE SETTING - P.S.I.

MFG., INC.
CINCINNATI, OHIO

TITLE	DATE	SECTION
REPLACEMENT PARTS	6-22-98A	C400
ET10K(X)	SUPERCEDES 2-20-90	900220



17256-3 ELEVATION CYLINDER

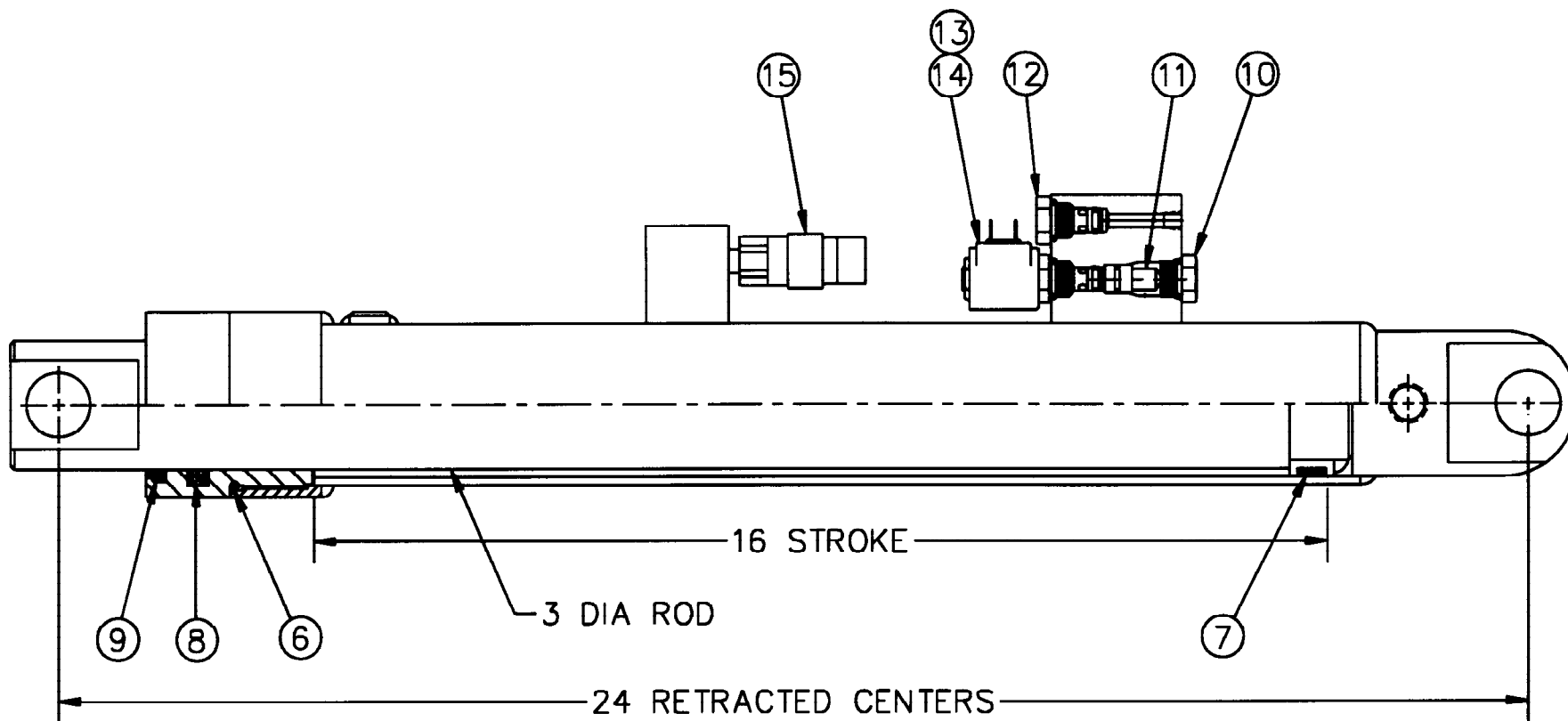

REPLACEMENT PARTS LIST REF 931130



MANUFACTURING, INC.
CINCINNATI, OHIO

TITLE	DATE	SECTION
ELEVATING CYL & VALVE ASSY PARTS	7-7-99D	C400
ET10K(X)	SUPERCEDES 4-29-99C	17257-3



REPLACEMENT PARTS LIST

17256-3 ELEVATION CYLINDER & VALVE ASSEMBLY

MODEL: ET10K(X)

ITEM	PART NUMBER	DESCRIPTION
1	17255-3	ELEVATING CYLINDER ASSEMBLY W/OUT VALVES & PRESSURE SWITCH
2	17256-3	ELEVATING CYLINDER ASSEMBLY WITH VALVES & PRESSURE SWITCH
3	-	-
4	-	-
5	-	-
6	*	O-RING
7	*	WEAR RING
8	*	POLYURETHANE PACKING (POLYPAK TYPE "B")
9	*	ROD WIPER
10	14416 	CAP
11	14450M-085	FLOW CONTROL VALVE
12	16917	CHECK VALVE
13	16918	SOLENOID VALVE (INCLUDES COIL)
14	16919	SOLENOID COIL ONLY
15	17460-2200-11	PRESSURE SWITCH
16	-	-
17	-	-
18	-	-
19	-	-
20	-	-
21	17376-3	PACKING KIT (INCLUDES ITEMS MARKED *)
22	-	-
23	-	-
24	-	-
25	-	-
26	-	-
27	-	-
28	-	-
29	-	-
30	-	-
31	-	-
32	-	-
33	-	-
34	-	-
35	-	-



ON CURRENT PRODUCTION CRANES, CAP HAS BEEN INCORPORATED INTO RETURN HOSE

MFG., INC.
CINCINNATI, OHIOTITLE
REPL. PARTS LIST

ET10K(X)

DATE
10-5-99DSUPERCEDES
5-3-99CSECTION
C400

931130



ET10K-7/15 17824 FIELD SERVICE LABEL KIT

ITEM	PARTNUMBER	QTY	DESCRIPTION
1	11917-1	1	12 VOLT DECAL
2	16973	2	UP ROTATION DECAL
3	13397	1	OIL LEVEL DECAL
4	14473-1	1	OIL DECAL
5	14473-2	3	GREASE DECAL
6	17389	2	VENTURO DECAL
7	15390	1	CAUTION, INSTRUCTIONS DECAL
8	15391	1	CRANE NOT PASSENGER LIFT DECAL
9	15392	1	DANGER ELECTROCUTION HAZZARD DECAL
10	15401	1	UNLAWFUL TO OPERATE DECAL
11	15398	1	UNPLUG PENDANT DECAL
12	15393	4	DANGER ELECTROCUTION HAZZARD DECAL
13	15394	1	ELECTRICAL HAZZARD SIGN
14	15513	1	ON / OFF PLATE DECAL
15	15581	1	ATTACHMENT DECAL
16	16789	1	WARNING - CHEMICALS DECAL
17	15538	1	WINCH BOOM ROTATION DECAL
18	17387	1	BOOM CAPACITY 7-11-15 DECAL
29	17388	1	BOOM CAPACITY 7-11-15 DECAL
20	17813	1	OVERLOAD SENSING DECAL
21	18719	1	DECAL APPLICATION DRAWING
22	17539	1	DECAL APPLICATION DRAWING
23	17381D	1	WIRING ET10K DECAL
24	19740	2	ET10K DECAL
25	25538	1	CONTROL PENDANT 3 SW DECAL
26	19731-2	2	SNATCH BLOCK DECAL (4000 LB)
27	▲ 20174	▲ 1	DECAL - GROUND CABLE ▲
28	-	-	-
39	-	-	-
30	-	-	-
31	-	-	-
32	-	-	-
33	-	-	-
34	-	-	-
35	-	-	-



MFG., INC.
CINCINNATI, OHIO

TITLE
FIELD SERV. LABEL KIT

ET10K-7/15

DATE
12-19-01A

SUPERCEDES
3-4-99

SECTION
-

17824

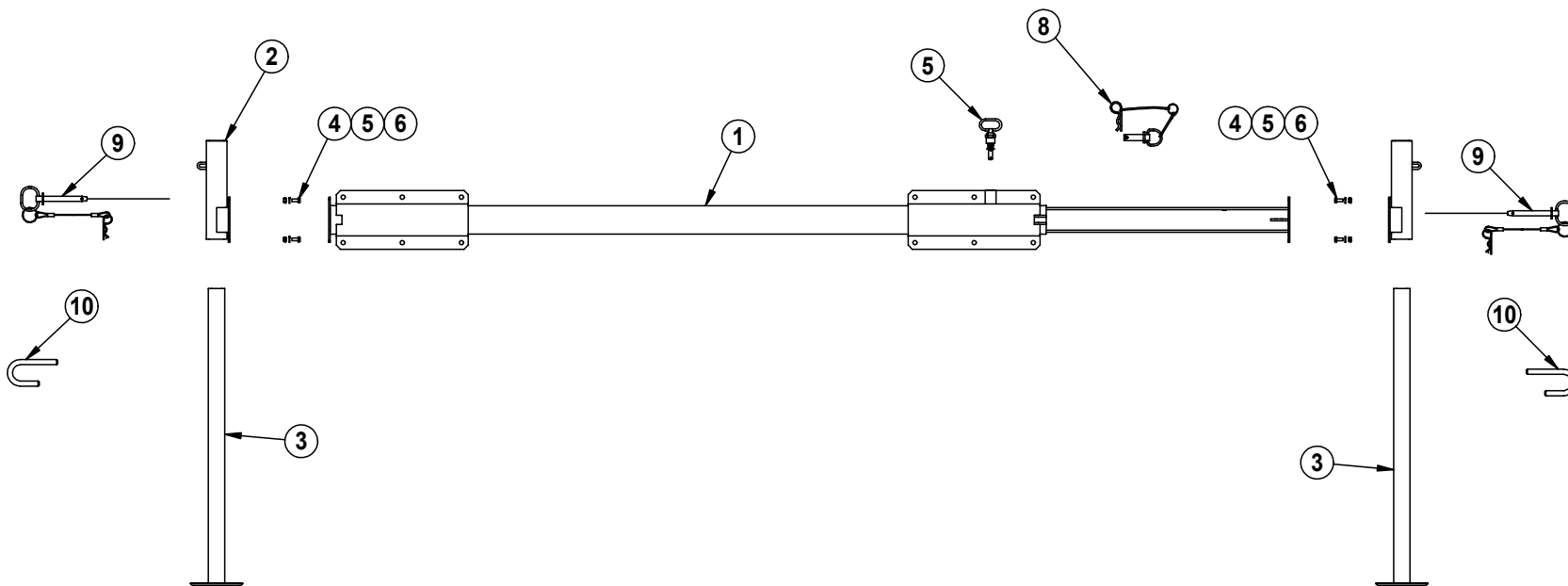

12	2	18506	3M BLACK / YELLOW SAFETY TAPE (NOT SHOWN)
11	2	14517	TAG, HANDLE INSTALLATION (NOT SHOWN)
10	2	23980	OUTRIGGER HANDLE
9	2	18607	HITCH PIN ASSEMBLY
8	1	24981	OUTRIGGER SECURITY PIN
7	1	18520	SPRING LOADED ASSEMBLY
6	8	!LWSH-031	LOCKWASHER - 5/16
5	8	!HNUT-03118	HEX NUT - 5/16-18
4	8	!HHCS03118075	HEX HEAD CAP SCREW - 5/16-18 X 3/4" LONG
3	2	13500-2	FIXED FOOT DROP LEG
2	2	18605	DROP LEG ADAPTER
1	1	18501	TUBE - OUTRIGGER ASSEMBLY
ITEM	QTY	PART NO	DESCRIPTION



TITLE
REPLACEMENT PARTS DWG & LIST

DATE
11-12-03

SECTION
C400

18500-P MANUAL OUTRIGGERS

SUPERSEDES
-

22688

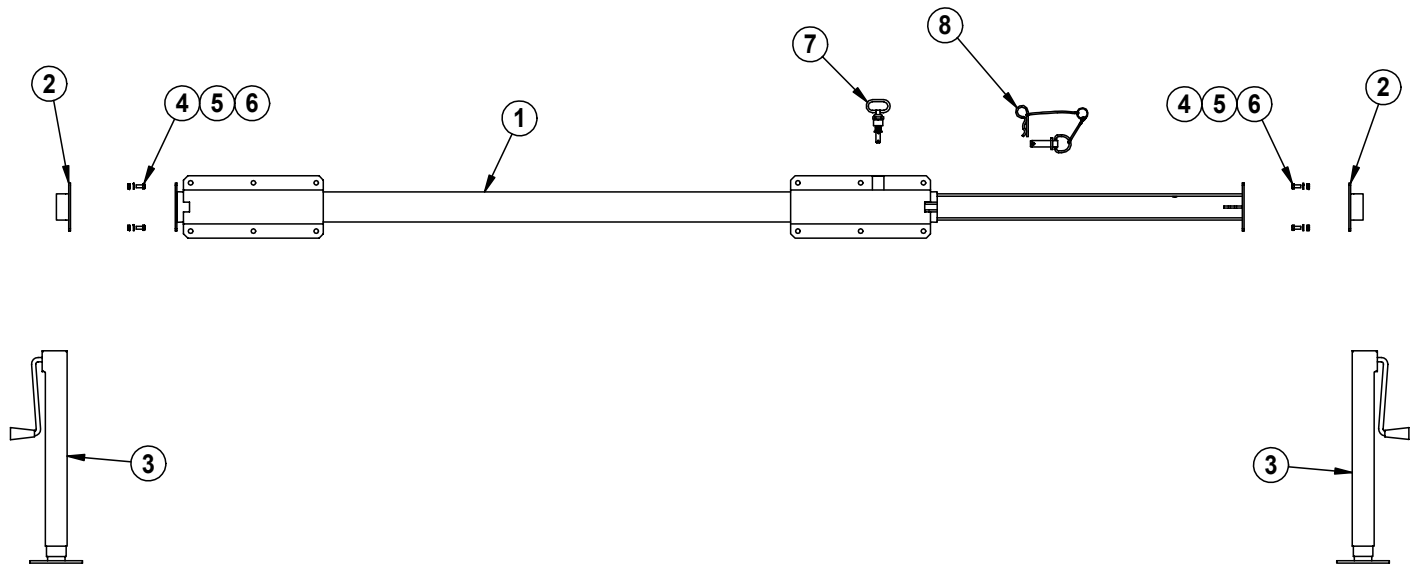

9	2	18506	3M BLACK / YELLOW SAFETY TAPE (NOT SHOWN)
8	1	24981	OUTRIGGER SECURITY PIN
7	1	18520	SPRING LOADED ASSEMBLY
6	8	!LWSH-031	LOCKWASHER - 5/16
5	8	!HNUT-03118	HEX NUT - 5/16-18
4	8	!HHCS03118075	HEX HEAD CAP SCREW - 5/16-18 X 3/4" LONG
3	2	18586	CRANKDOWN LEG
2	2	18587	CRANKDOWN LEG ADAPTER
1	1	18501	TUBE - OUTRIGGER ASSEMBLY
ITEM	QTY	PART NO	DESCRIPTION



TITLE
REPLACEMENT PARTS DWG & LIST

DATE
11-12-03

SECTION
C400

18500-CD MANUAL OUTRIGGERS

SUPERSEDES
-

22689