



SERVICE
TRUCKS
INTERNATIONAL

A Division of Sioux Automation Center Inc.

America's Premier Manufacturer of
Service Equipment

TIGER CRANES

QUALITY-PERFORMANCE-RELIABILITY

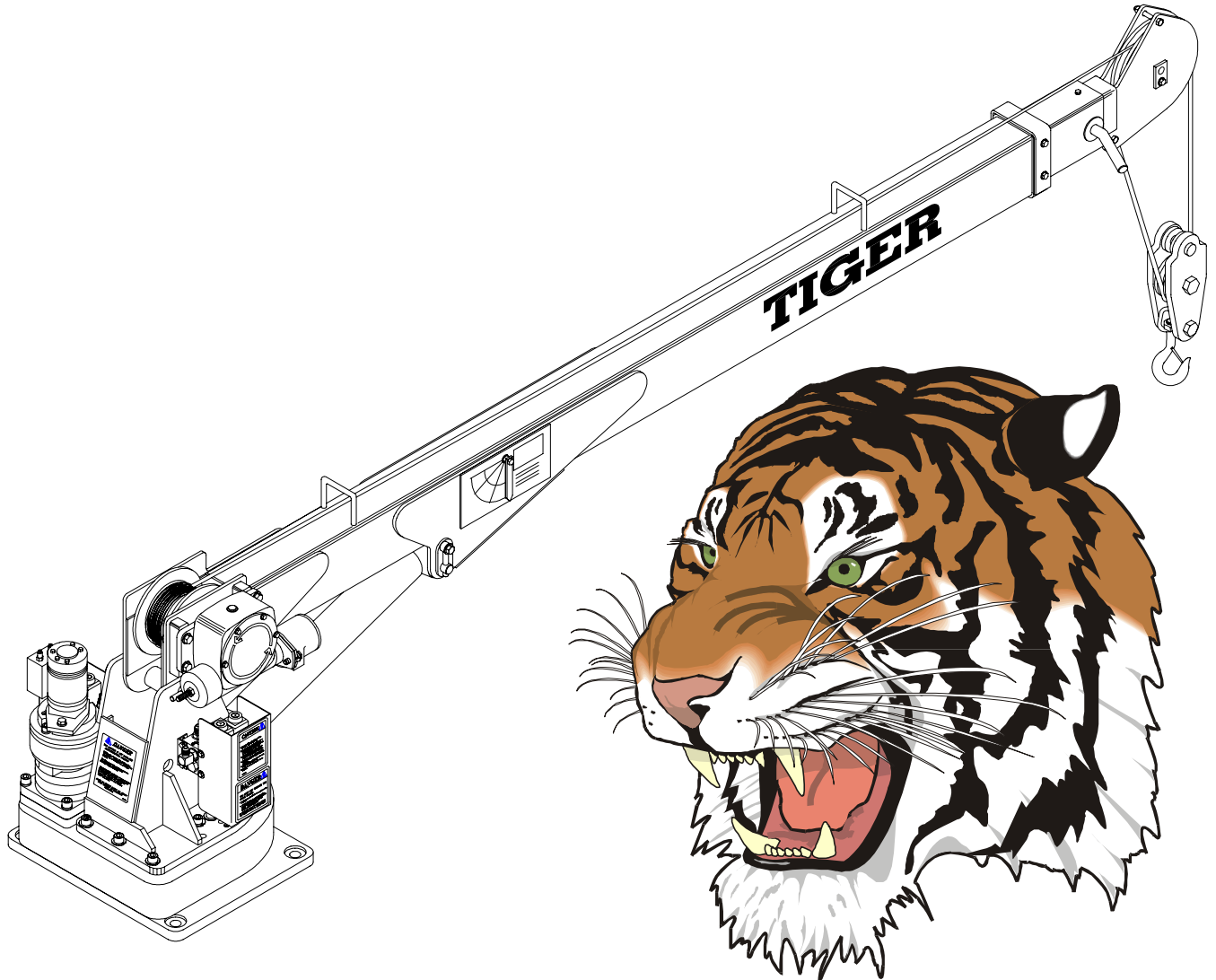

CRANE MODEL: 8000 OPERATION AND MAINTENANCE MANUAL

877 1st AVE. NW Sioux Center, IA 51250 Toll Free: 1-866-225-8789 Phone: 1-712-722-3711

www.servicetrucks.com

STI610392

6/23/04

\$15



View thousands of Crane Specifications on FreeCraneSpecs.com



TAKE NOTE! THIS SAFETY ALERT SYMBOL FOUND THROUGHOUT THIS MANUAL IS USED TO CALL YOUR ATTENTION TO INSTRUCTIONS INVOLVING YOUR PERSONAL SAFETY AND THE SAFETY OF OTHERS. FAILURE TO FOLLOW THESE INSTRUCTIONS CAN RESULT IN INJURY OR DEATH.



THIS SYMBOL MEANS

- ATTENTION!**
- BECOME ALERT!**
- YOUR SAFETY IS INVOLVED!**

SIGNAL WORDS:

Note the use of the signal words DANGER, WARNING and CAUTION with the safety messages. The appropriate Signal word for each has been selected using the following guidelines:

DANGER: Indicates an imminently hazardous situation that, if not avoided, will result in death or serious injury. This signal word is limited to the most extreme situations typically for machine components that cannot be guarded for functional purposes.

WARNING: Indicates a potentially hazardous situation that, if not avoided, could result in death or serious injury, and includes hazards that are exposed when guards are removed. It may also be used to alert against unsafe practices.

CAUTION: Indicates a potentially hazardous situation that, if not avoided, may result in minor or moderate injury. It may also be used to alert against unsafe practices.

If you have any questions not answered in this manual or require additional copies or the manual is damaged, please contact your dealer or Sioux Automation Center, Inc., 877 1st Avenue N.W., Sioux Center, IA, 51250. (Telephone) 712-722-3711, (Fax) 712-722-3706.



View thousands of Crane Specifications on FreeCraneSpecs.com



INTRODUCTION

READ CAREFULLY

This manual is provided to familiarize you with the operation of your S.T.I. truck mounted 8000 hydraulic service crane and to supply you with the information necessary for proper equipment maintenance.

It is the user's responsibility to maintain and operate this crane in a manner that will result in the safest working conditions possible.

In addition, it is also the user's responsibility to be aware of existing Federal, State and Local codes and regulations governing the safe use and maintenance of this unit. Listed below is a publication that the user should read and understand.

ANSI - ASME B30.5 - 1982
MOBILE AND LOCOMOTIVE CRANES
The American Society of Mechanical Engineers
United Engineering Center
345 East 47th Street
New York, NY 10017

Warranty of this unit will be void on any part of the unit subject to misuse due to overloading, abuse, lack of maintenance or unauthorized modifications. No warranty - verbal, written or implied - other than the official published S.T.I. new machinery and equipment warranty will be valid with this unit.

**Treat the equipment with respect and service it regularly.
These two things can add up to a safer working environment
and longer equipment life.**



TABLE OF CONTENTS

| INTRODUCTION | PAGE |
|--|-------|
| Section 1 Installation | 1 - 2 |
| Section 2 OPERATION..... | 3 - 6 |
| 2.1 General..... | 3 |
| 2.2 Load Limits..... | 3 |
| 2.3 Equipment Inspection | 3 |
| 2.4 Operating Restriction | 4 |
| 2.5 Load Lifting | 5 |
| 2.6 Speed Control Operation | 5 |
| 2.7 Task Performance | 5 |
| 2.8 Shutdown | 5-6 |
| Section 3 MAINTENANCE..... | 6 - 9 |
| 3.1 General..... | 6 |
| 3.2 Lubrication..... | 6 |
| 3.3 Hydraulic Fluid Specification..... | 6-7 |
| 3.4 Hydraulic Oil Deterioration | 7 |
| 3.5 Purging Air from the System | 7-8 |
| 3.6 System Relief Pressure | 8 |
| 3.7 Remote Control Maintenance | 8 |
| 3.8 Rotation Gear..... | 8 |
| 3.9 Worm Gear Adjustment..... | 8 |
| Section 4 TROUBLE-SHOOTING GUIDE..... | 9 |

APPENDIX:

Note: Read the entire manual before installing or operating crane



SECTION 1 - INSTALLATION

These instructions are intended as a guide to assist you with your particular installation. We cannot cover every make, model and year of truck manufactured worldwide, so these instructions will provide only general information.

1. Inspect the carrier vehicle to make certain it complies with the minimum chassis requirements indicated for this model of service crane.
2. Be certain that any modifications made to stiffen or reinforce the truck body have been done according to the instructions of the body manufacturer.
3. Never weld, modify, or use unauthorized components on any S.T.I. units. This will void any warranty or liability and may result in a failure of the crane.
4. Install the boom cradle on the truck
5. Lift the crane to a height which is sufficient to allow for positioning the truck body underneath it. Mounting bolts, or bolt holes, should be in position to receive or line up with the bolt hole pattern on the base plate of the crane.
6. With the boom pointing toward the front of the truck, lower the crane into place and tighten the bolt nuts to the proper torque. Make sure the boom is resting properly in its support.
7. Connect the hydraulic pump to the crane. Two hydraulic fittings are located inside the crane base and are accessible from the underside of the base plate. The pressure fitting is color coded with blue dykem. The pressure relief valve must be installed across the pressure and return lines and should be located in an accessible position. Recommended PSI operating ranges between crack pressure and full flow are as follows:

8000 2450 - 2650 PSI

NOTE: It is recommended that both the pressure and return lines on the 8000 be no less than 3/4". Do Not use hose on the hydraulic system of less than 100R1 rating.

8. The four strand power cord on the 8000 hydraulic provides power to the remote controller receptacle on the crane base and is accessible from the underside of the base plate. The four-strand power cord contains four wires and should be connected as shown in the wiring diagram included in the appendix of this manual.



9. After the crane has been installed:
 - Check all hydraulic lines for:
 - Sharp corners (which may cut into hose) and kinks
 - Abrasions and chafing
 - Tightness of fittings
 - Leaks
 - Check all bolts and pins
 - Visually inspect all welds for cracks, holes, etc.
 - Engage Power Take-Off
 - Slowly operate crane through all functions. Inspect all hoses, cylinders and structural members for proper operation.
 - Return crane boom to its support and the unit is ready for operation.
10. If you wish to ensure that the pressure settings are correct to allow the crane to lift the proper loads within the recommended radius, utilize the following test procedure:
 - Park the truck on solid, level ground
 - Extend the outriggers
 - Rotate the boom so that it is pointing out over the rear of the truck
 - Position the boom at the 0 degree radius
 - Extend the boom to maximum length
 - Attach a test weight in the amount allowed for that unit , at 0 degrees, in a fully extended position
 - Lift the weight using only the boom to the 45-degree position. Then rotate it 90 degrees in each direction to ensure free rotation, and eliminate any air pockets in the system
 - If the boom will not pick the load, ensure that the boom is at the 0 degree position, and the test weight is not more than the crane is rated for at that position
 - After the test has been completed, return the boom to the normal transport position



SECTION 2 - OPERATION

2.1 GENERAL

The crane is relatively simple to operate. However, prior to any work at job sites, the operator should thoroughly familiarize him or her self with the control operating procedures and practices for this unit. In addition, the operator should perform practice job operations before putting the unit to a task. The operator's understanding of emergency measure execution is essential; he or she should be prepared to take emergency control at any time.

2.2 LOAD LIMITS

The crane is designed to provide excellent service if operated within maximum allowable load specifications stated on the unit's Angle Indicator Plate attached to both sides of the boom. The plate should be studied before lifting operation are started. Exceeding the stated load limit for a given radius of operation can cause tipping or structural failure and void the warranty.

2.3 EQUIPMENT INSPECTION

Before operating the unit, always perform the safety checks outlined in this section. These procedures are vital to the detection of equipment malfunctions, which may be potential safety hazards.

A. Structural Soundness

- Inspect the unit for damaged members and loose nut or bolts

B. Hydraulic Oil Supply

- With the crane in a stored position, and all cylinders retracted, check the oil level

C. Leakage

- Examine all of the visible hydraulic lines for frays and blisters. Look for signs of lubricating or hydraulic oil leakage

D. Controls

- Make a short test for proper control operation

E. Inspect for damaged, kinked or frayed winch cable

F. Repairs

- Correct all observed defects and malfunctions before putting the unit into service



2.4 OPERATING RESTRICTIONS

Listed below are important points to remember while operating the unit.

- A. Keep the vehicle as level as possible while loading or unloading
- B. **ALWAYS** set the vehicle emergency brake before beginning crane operations
- C. **ALWAYS** use outriggers from vehicle to the ground during crane operations. Ensure they are positioned on solid footings.
- D. **ALWAYS** depress the clutch pedal before engaging or disengaging the PTO
- E. **ALWAYS** extend the winch cable before extending the boom.
- F. **ALWAYS** keep the load as close to the ground as possible
- G. **NEVER** swing a load so that it passes over people
- H. **NEVER** rotate the crane too fast with a load
- I. **NEVER** operate the crane if in any position it will be within ten feet of a power line
- J. **NEVER** exceed the rated lifting capacities. Deduct the weight of any load handling equipment from the rated capacity.
- K. **NEVER** leave a load suspended in the air
- L. **NEVER** use the winch to drag a load into position before lifting
- M. **NEVER** side load the boom by dragging a load from the side
- N. **NEVER** use the crane for lifting people
- O. **NEVER** operate the crane during an electrical storm or in high wind conditions
- P. **NEVER** attempt to service or repair the crane while the crane is operating
- Q. **NEVER CONTINUE TO ROTATE CRANE IN ONLY ONE DIRECTION.**
The direction of rotation must be alternated to avoid damage to wire harness assembly



2.5 LOAD LIFTING

It must be understood that all load ratings are formulated on 85% of tipping. Tipping is defined as a tire bearing contact with the ground. All load ratings are dependent upon compliance with the following:

- A. The crane has been correctly installed on a truck in accordance with the chassis requirements and truck body manufacturers specifications are reinforcement
- B. The intended operation is to be carried out on level, solid footing with proper outrigger placement

2.6 SPEED CONTROL OPERATION

The boom lift cylinder and rotation drive unit are both equipped with manual adjustable speed controls. The lift cylinder speed is controlled by needle valves located on the lift cylinder and the rotation drive speed is set at the factory to provide one half (1/2) revolution per minute.

2.7 TASK PERFORMANCE

To operate the crane:

- A. Position the crane as close to the job as possible on a firm, dry and level surface. Avoid overhead obstruction on the work side of the unit
- B. Set the parking brake
- C. Shift the transmission into neutral and engage the PTO
- D. Extend and lower the outriggers until firm ground contact is made. On soft ground, use bearing pads to prevent sinking
- E. Before extending the boom, always pay out the winch cable. Failure to do so may result in damaging the cable and cable failure

S.T.I. cranes are equipped with counter balance valves inside of the lift cylinder. This valve functions as a deceleration control and serves as a safety device locking the load in case of a hydraulic line breakage or in the event of accidental or unauthorized operation of the directional valve when the pump is not operating.

The valve is equipped with a manual load release, which is to be used only in case of an emergency.

2.8 SHUTDOWN

- A. Retract the boom and cable, making sure cable is properly wrapped on winch spool
- B. Place the crane in a travel position



- C. Secure the hook
- D. Stow the outriggers
- E. Disengage the PTO

SECTION 3 - MAINTENANCE

3.1 GENERAL

A proper maintenance schedule, performed on a regular basis is essential in keeping the crane operating safely at peak efficiency

3.2 LUBRICATION

The intervals for all lubrications are weekly. However, maintaining the proper lubrication schedule will vary with climatic conditions and the amount of usage the unit receives. Periods of heavy use would shorten service intervals. See lubrication points and recommended lubricants.

STI\691810
1:18 BM

MODEL 8000
RECOMMENDED LUBRICANTS

| ITEM | LUBRICANT |
|------|------------------------|
| 1 | MOBIL CMD GREASE |
| 2 | MOBILUBE 85W140 |
| 3 | AMCO RVKON #2EP GREASE |
| 4 | AMCO RVKON #2EP GREASE |
| 5 | AMCO RVKON #2EP GREASE |
| 6 | AMCO RVKON #2EP GREASE |
| 7 | AMCO RVKON #2EP GREASE |
| 8 | AMCO RVKON #2EP GREASE |
| 9 | AMCO RVKON #2EP GREASE |
| 10 | AMCO RVKON #2EP GREASE |

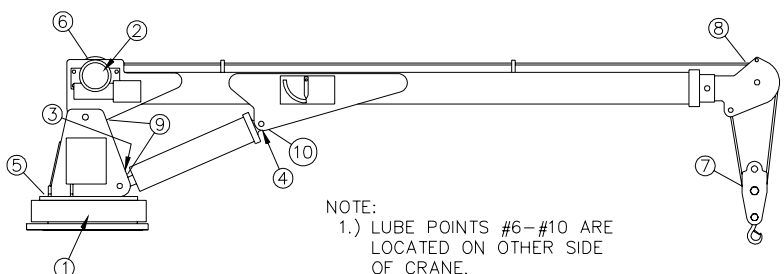

NOTE:

1.) LUBE POINTS #6-#10 ARE
LOCATED ON OTHER SIDE
OF CRANE.

3.3 HYDRAULIC FLUID SPECIFICATION

Minimum viscosity specifications for hydraulic oil to be used in the crane should be MOBIL DTE13M or equivalent to eliminate the necessity of seasonal oil changes under normal temperature conditions. For operations in extremely cold temperature, use a hydraulic fluid having a viscosity of 3000 SSU's at the lowest temperature encountered. Operating temperature of the hydraulic fluid should be within the range of 120 degrees to 160 degrees F(49 degrees C to 82 degrees C).



NOTE: Subzero conditions present special requirements and considerations. Consult your oil supplier for the proper fluid for working under these severe conditions.

In addition to conforming the viscosity requirements, hydraulic fluid used in the system should contain the following additives:

Anti-foam, Anti-oxidant inhibitors
Rust resistant, Anti-wear additives

3.4 HYDRAULIC OIL DETERIORATION

Hydraulic oil that becomes contaminated with solvents, water, dust or other abrasives will result in premature breakdown of the oil's anti-foam, lubrication, anti-rust and viscosity properties. Periodically, a sample of the hydraulic oil in the system should be taken and its condition checked for breakdown. To check oil quality:

- A. Place sample of oil in clean glass
- B. Smell oil to see if a burnt or rancid odor can be detected
- C. Examine the oil for an unusually dark or cloudy appearance
- D. Allow the sample to stand undisturbed for several minutes and inspect it for water or impurities which will settle to the bottom

If any of the above conditions are noticed, the system should be purged to the bottom and filled with new oil.

3.5 HYDRAULIC SYSTEM PURGING

The oil should be changed after 600 hours of operation or every six months, whichever occurs first.

The following is the procedure for purging the system:

- A. Locate the unit in an area which provides solid, level footing and space to allow the full operating range to the crane.
- B. Stabilize the unit with the outriggers. Move the crane to either side of the truck and extend the extension and lift cylinders.
- C. Disengage the PTO, drain the hydraulic fluid reservoir, remove the suction line filter and drain all the hoses. Disconnect the pressure hose from the pump, drain and reassemble. Replace the suction line filter element and reassemble the system.
- D. Install the drain plug on the reservoir and fill with new fluid. Remove the reservoir return line and direct the flow into a sump or waste container.
- E. Start the truck engine, engage the PTO. Rotate the crane 90 degrees, retract the extension boom and lower the main boom.



- F. The system is now purged. Replace the return line filter cartridge and reinstall the return line to the reservoir.
- G. Examine the reservoir fluid level and add fluid to the “FULL” mark.

3.6 PURGING AIR FROM THE SYSTEM

If air is trapped in the cylinder, it will cause an erratic “bumpy” condition. To remove the air, hold the affected control open after the function has “bottomed out”. Move the function in the opposite direction and again hold the control open. Operate the crane in a normal manner to determine if the air has been purged. If not, repeat procedure.

3.7 SYSTEM RELIEF PRESSURE

If you wish to ensure that the relief pressure setting is correct, it will be necessary to install a pressure gauge in the 1/4" NPT near the front top side of valve manifold. The test can be performed by utilizing either the boom cylinder or the extend cylinder. Fully retract either cylinder and hold in while observing pressure reading on gauge.

- A. Start the truck engine, engage the PTO and allow the system to idle until it reaches operating temperature
- B. Raise the boom until the cylinder is fully extended. Continue to hold the valve open and read the pressure on a pressure gauge. A reading of less than normal should be corrected by increasing the pressure.

If the pressure reading is too high or too low, it will be necessary to adjust the relief valve set screw.

Adjustments are made by unlocking the jam nut and turning set screw clockwise to increase pressure and counter clockwise to decrease pressure.

Recommended PSI ranges between crack pressure and full flow should be 2450-2550 PSI

3.8 REMOTE CONTROL MAINTENANCE

The remote control is subject to corrosion and must be checked at least twice a year and more often if operated in sever, wet conditions. To check for corrosion:

- A. Remove the cover plate and inspect for a lack of luster. Metals should appear bright and untarnished.
- B. Spray the inside of the box with an ignition sealer such as Krylon.

3.9 ROTATION GEAR

No adjustments are to be made to the 8000 Planetary Drive without prior consultation with the factory. The Planetary Drive is set at the factory and should require not adjustment.



SECTION 4 - TROUBLE-SHOOTING

The following is meant as a reference in diagnosing on-the-job-malfunctions.

| <u>SYMPTON</u> | <u>PROBABLE CAUSE</u> |
|---|---|
| Function does not respond controls | <ul style="list-style-type: none"> ➤ Hydraulic fluid low ➤ PTO not engaged ➤ Ruptures/obstructed pressure line ➤ Faulty hydraulic pump ➤ Short circuit in remote control ➤ Broken wire in remote control ➤ Crane in not grounded to truck ➤ Solenoid in control valve malfunctioning ➤ Bad ground on the control valve |
| Slowdown of functions | <ul style="list-style-type: none"> ➤ Hydraulic pump operating at reduced speed ➤ Relief valve set too low ➤ Low hydraulic fluid ➤ Dirty filter/strainer ➤ Obstruction in solenoid control valve |
| Boom drifts under load | <ul style="list-style-type: none"> ➤ Cylinder piston seals leaking ➤ Counterbalance valve defective |
| Boom or winch won't lift | <ul style="list-style-type: none"> ➤ Restriction in the line ➤ Relief valve is not set properly ➤ Overload condition ➤ Counterbalance valve is malfunctioning or defective |
| Rotation speed too fast or too slow | <ul style="list-style-type: none"> ➤ Adjust speed set improperly ➤ Control valve defective |
| Unusual noise in operation | <ul style="list-style-type: none"> ➤ Cavitation due to low hydraulic oil supply ➤ Excessive loading ➤ Restriction/collapse of suction line ➤ Suction line filter dirty ➤ Relief valve set too low ➤ Relief valve defective ➤ Air in the lines |
| Crane will not rotate | <ul style="list-style-type: none"> ➤ Hydraulic fluid level low ➤ Obstruction in control valve solenoid ➤ Adjustable speed set improperly ➤ Bad ground on the control valves |
| Outriggers wont react malfunctions or defective | <ul style="list-style-type: none"> ➤ Hydraulic lines restricted or ruptured ➤ Cylinder is defective |



DWG NO. STI400086
DO NOT SCALE DRAWING

| | | | | | | |
|------|--|---|------------------------|------|-----|-------|
| 2264 | | A | ADDED ASTERISK CALLOUT | 7-03 | JGS | REV _ |
|------|--|---|------------------------|------|-----|-------|

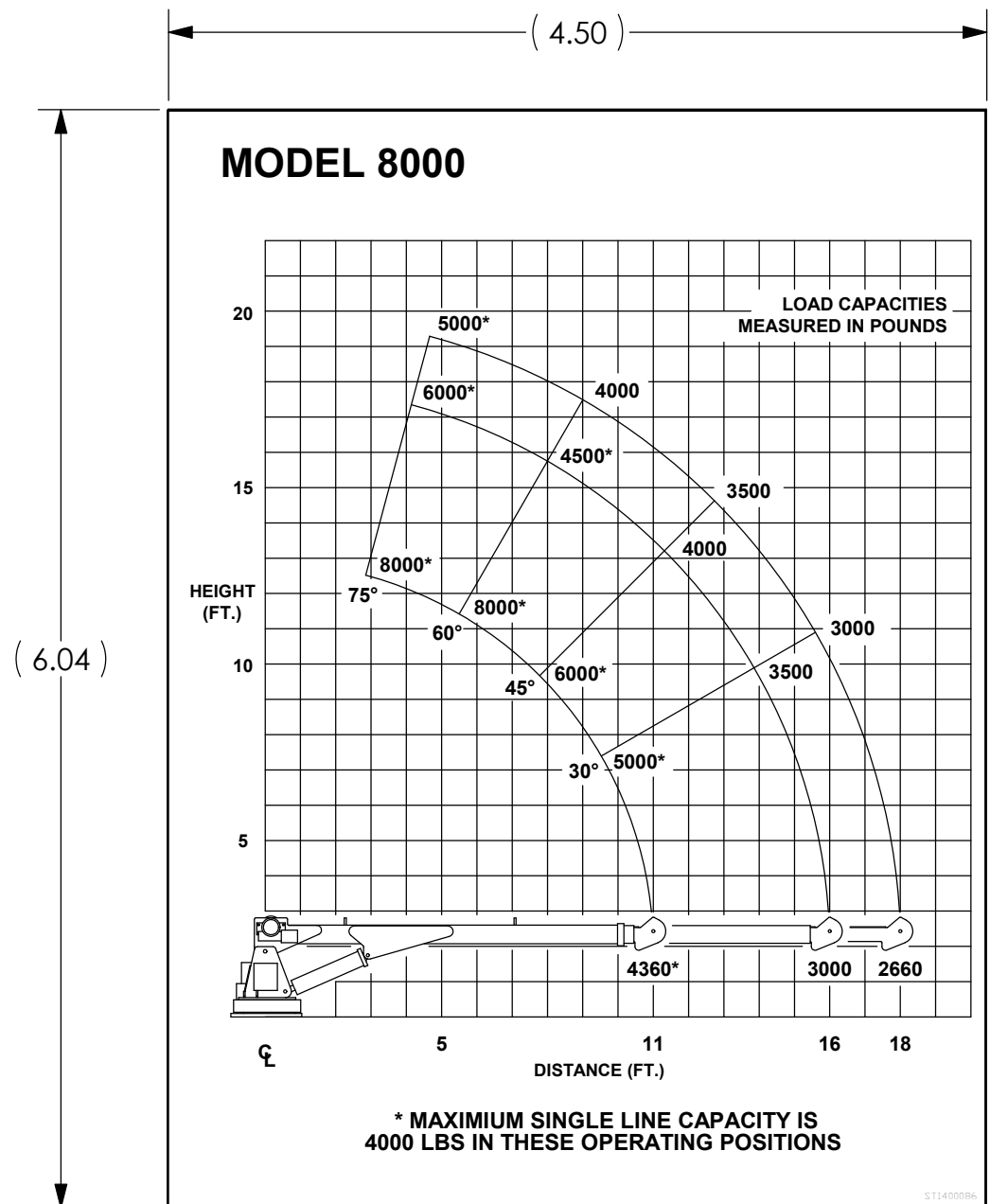

NOTE:
MATERIAL 5-8 YEAR CAST VINYL
WITH PERMANENT PRESSURE SENSITIVE
ADHESIVE AND CLEAR UV COATING
OR EQUIVALENT

| | | |
|--|------------------------------|---|
| DRAWN CAS | DATE 3-01 | PROPERTY OF: SERVICE TRUCKS INTERNATIONAL A DIVISION OF SIOUX AUTOMATION CENTER INC. 877 FIRST AVE NW SIOUX CENTER, IA 51250 |
| CHECKED | DATE | |
| SCALE 1:1 | BREAK ALL EDGES .03 X 45° | DECAL, CHART, LOAD, 8K |
| DIMENSIONS ARE IN INCHES TOLERANCES UNLESS SPECIFIED FRACTIONAL ± 1/32 3 PLACE ± .005 2 PLACE ± .020 ANGULAR ± 1° | | |
| MATERIAL AS NOTED | SIZE B | |
| | | REV - |
| | | SHEET 1 OF 1 |



| | |
|----------------------|-----------------------|
| DWG. NO. | STI\690010 |
| DO NOT SCALE DRAWING | |
| OPTION | OPTION DESCRIPTION |
| B | 2 FT EXTENDED BOOM |
| C | 4 FT EXTENDED BOOM |
| D | PROPORTIONAL CONTROLS |
| E | STAINLESS STEEL CABLE |
| F | OVERLOAD PROTECTION |
| | STANDARD EQUIPMENT |

| REVISIONS | | | | | REV | C |
|-----------|-----|--------------------------|------|-----|-----|---|
| ECN | REV | DESCRIPTION | DATE | BY | CHK | |
| | A | COMBINED PRINTS | 8-99 | BM | | |
| 1635 | B | ADD OPTIONS & LEVEL INFO | 4-02 | CAS | | |
| 2160 | C | REMOVED ATB OPTION | 5-03 | JGS | | |



WARNING!

READ ENTIRE MANUAL BEFORE SERVICING OR OPERATING THIS CRANE.

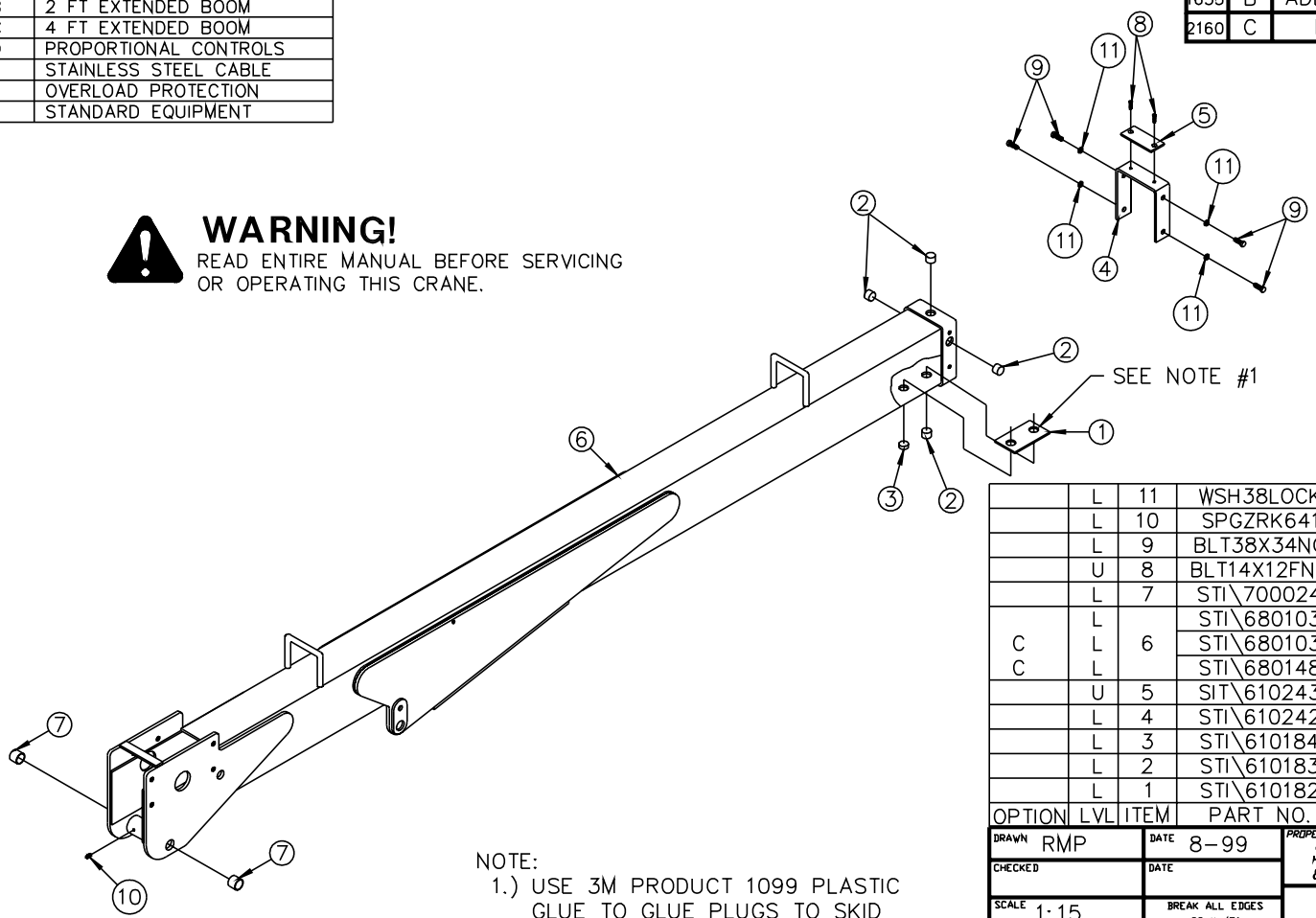

| OPTION | LVL | ITEM | PART NO. | QTY. | DESCRIPTION |
|--------|-----|------|-------------|------|-------------------------------|
| | L | 11 | WSH38LOCK | 4 | WSH,LOCK,3/8 |
| | L | 10 | SPGZRK641 | 1 | ZRK,GREASE,641,1/4-28,.547 |
| | L | 9 | BLT38X34NC | 4 | BLT,SHCS,3/8,3/4,NC |
| | U | 8 | BLT14X12FNC | 2 | BLT,FLAT,1/4,1/2,NC,G5 |
| | L | 7 | STI\700024 | 2 | BUSHING,GARLOCK,1.25,1.12,1 |
| C | L | | STI\680103 | 1 | BOOM,MAIN,WLD,6K,8K |
| C | L | 6 | STI\680103 | -1 | BOOM,MAIN,WLD,6K,8K |
| | L | | STI\680148 | 1 | BOOM,MAIN,WLD,6K,8K,24,EXT |
| | U | 5 | SIT\610243 | 1 | RTNR,WEAR,.19,2,4.5,NYL |
| | L | 4 | STI\610242 | 1 | RTNR,PLUG,GUIDE,BOOM,6.38,5.5 |
| | L | 3 | STI\610184 | 1 | STI1NYL,.38 |
| | L | 2 | STI\610183 | 4 | STI1NYL,.69 |
| | L | 1 | STI\610182 | 1 | SKID,.19,3,5.25,NYL |

NOTE:
1.) USE 3M PRODUCT 1099 PLASTIC GLUE TO GLUE PLUGS TO SKID PLATE. (2 PLCS.)

| | | | | | |
|--|----------|------------------------------|------|---|--------------------------------------|
| DRAWN | RMP | DATE | 8-99 | PROPERTY OF | SIoux AUTOMATION CENTER, INC. |
| CHECKED | | DATE | | 877 FIRST AVE NW SIOUX CENTER, IOWA 51250 | |
| SCALE | 1:15 | BREAK ALL EDGES .03 x 45° | | BOOM, ASSY, #1 | |
| DIMENSIONS ARE IN INCHES TOLERANCES UNLESS SPECIFIED FRACTIONAL ± 1/32 3 PLACE ± .005 2 PLACE ± .020 ANGULAR ± 1° | | | | | |
| MATERIAL | AS NOTED | SIZE | B | DWG NO. | STI\690010 |
| | | | | REV | C |



| DWG. NO. STI\691801 | |
|----------------------|-----------------------|
| DO NOT SCALE DRAWING | |
| OPTION | OPTION DESCRIPTION |
| B | 2 FT EXTENDED BOOM |
| C | 4 FT EXTENDED BOOM |
| D | PROPORTIONAL CONTROLS |
| E | STAINLESS STEEL CABLE |
| F | OVERLOAD PROTECTION |
| | STANDARD EQUIPMENT |

| REVISIONS | | | | | REV |
|-----------|-----|----------------|------|-----|-----|
| ECN | REV | DESCRIPTION | DATE | BY | CHK |
| 2160 | F | DEL ATB OPTION | 7-03 | JGS | |

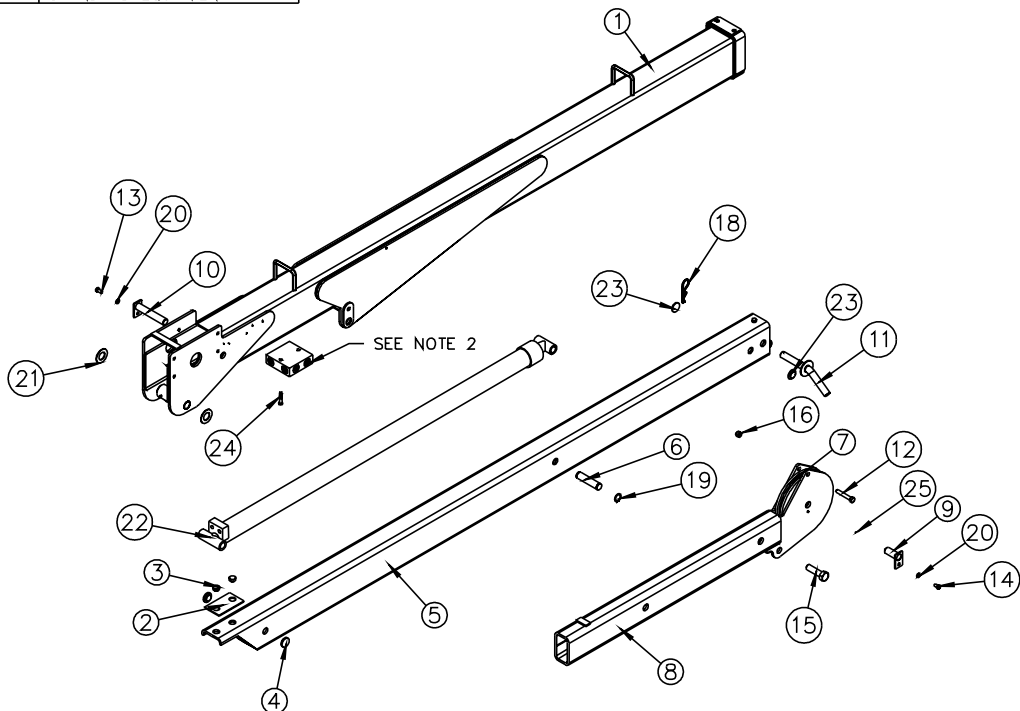

NOTE:
 1) USE 3M PRODUCT 1099 PLASTIC GLUE TO GLUE PLUGS TO SKID PLATE.
 2) PART NUMBER FOR VALVE BLOCK IS ON HYD. PRINT STI691812

| | | | | |
|-----|----|---------------|----|----------------------------|
| L | 25 | SPGZRK641 | 1 | ZRK,GRS,1/4-28,MALE,STR |
| L | 24 | BLT516X112NC | 2 | BLT,HEX,5/16,1-1/2,NC,G5 |
| L | 23 | STI610403 | 2 | PLUG,GUIDE,BOOM,1.5,NYL,13 |
| L | 22 | STI700020 | 0 | CYL,EXTNSN,8K,6K |
| L | 21 | STI610337 | 2 | WSH,PIVOT,UHMW,100 |
| L | 20 | WSH38LOCK | 2 | WSH,LOCK,3/8 |
| U | 20 | WSH38LOCK | 1 | WSH,LOCK,3/8 |
| L | 19 | SPOSRG1 | 2 | RING,SNAP,OUTSIDE,1 |
| U | 18 | SPHPN316 | 1 | PIN,HAIR,3/16 |
| U | 17 | NUT78JAMLNF | 1 | NUT,JAM,7/8,NF,G8 |
| L | 16 | NUT12NYLOCKNC | 1 | NUT,LOCK,NYLOCK,1/2,NC |
| U | 15 | BLT78X3NFG5 | 1 | BLT,HEX,7/8,3,NF,G5 |
| U | 14 | BLT38X58NC | 1 | BLT,HEX,3/8,5/8,NC,G5 |
| L | 13 | BLT38X34NC | 2 | BLT,HEX,3/8,3/4,NC,G5 |
| L | 12 | BLT12X3NC | 1 | BLT,HEX,1/4,3,NC,G5 |
| U | 11 | STI680106 | 1 | PIN,LOCK,JIB,WLD,1 |
| L | 10 | STI680107 | 1 | PIN,LOCK,CYL,WLD,1.5,75 |
| U | 9 | STI680100 | 1 | PIN,SHEAVE,WLD,1,2,38 |
| L | 8 | STI680001 | 1 | END,JIB,WLD,6K,8K |
| L | 7 | STI680000 | 1 | SHEAVE,CABLE,10,ASSY,NYL |
| L | 6 | STI610258 | 1 | PIN,BOOM,INNER,1 |
| L | | STI610315 | 1 | BOOM,INNER,8K |
| B,C | | STI610315 | -1 | BOOM,INNER,8K |
| B | | STI610347 | 1 | BOOM,INNER,6K,8K,24 |
| C | | STI610366 | 1 | BOOM,INNER,8K,48 |
| L | 4 | STI610239 | 3 | PLUG,GUIDE,BOOM,1.5,NYL |
| L | 3 | STI610184 | 2 | STI1NYL,38 |
| L | 2 | STI610182 | 1 | SKID,19,3,5,25,NYL |
| | 1 | STI690010 | 1 | BOOM,ASSY,#1 (REF) |

| OPTION | LVL | ITEM NO. | PART NO. | QTY. | DESCRIPTION |
|--|----------|-----------------|-----------|--|-------------|
| DRAWN | RMP | DATE | 5-99 | PROPERTY OF SERVICE TRUCKS INTERNATIONAL A DIVISION OF SIOUX AUTOMATION CENTER, INC. 877 FIRST AVE NW SIOUX CENTER, IOWA 51250 | |
| CHECKED | | DATE | | | |
| SCALE | 1:18 | BREAK ALL EDGES | .03 x 45° | BOOM,8K,#2,ASSY | |
| DIMENSIONS ARE IN INCHES TOLERANCES UNLESS SPECIFIED FRACTIONAL ± 1/32 3 PLACE ± .005 2 PLACE ± .020 ANGLE ± 1° | | | | | |
| MATERIAL | AS NOTED | SIZE | B | DWG NO. | STI\691801 |
| | | | | REV | F |



DWG NO. STI691802
DO NOT SCALE DRAWING

| REVISIONS | | | | | | REV D |
|-----------|------|-------------------------------|-------|----|----|-------|
| ECN | REV. | DESCRIPTION | DATE | BY | CK | |
| | A | BLT58X212NCML WAS BLT58X212NC | 8-00 | NS | | |
| 1635 | B | ADD OPTIONS & LEVEL INFO | 4-02 | CS | | |
| 1853 | C | DELETE OPTIONS & LEVEL INFO | 9-02 | AP | | |
| 3300 | D | SEE ECN #3300 FOR CHANGES | 12-04 | SZ | | |

NOTE: ITEMS STI680139 AND STI680124 ARE INCLUDED IN THE BOM OF HYD PRINT #STI\691812

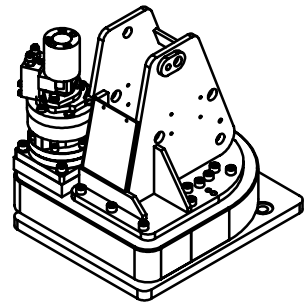

ISO VIEW AFTER ASSEMBLY

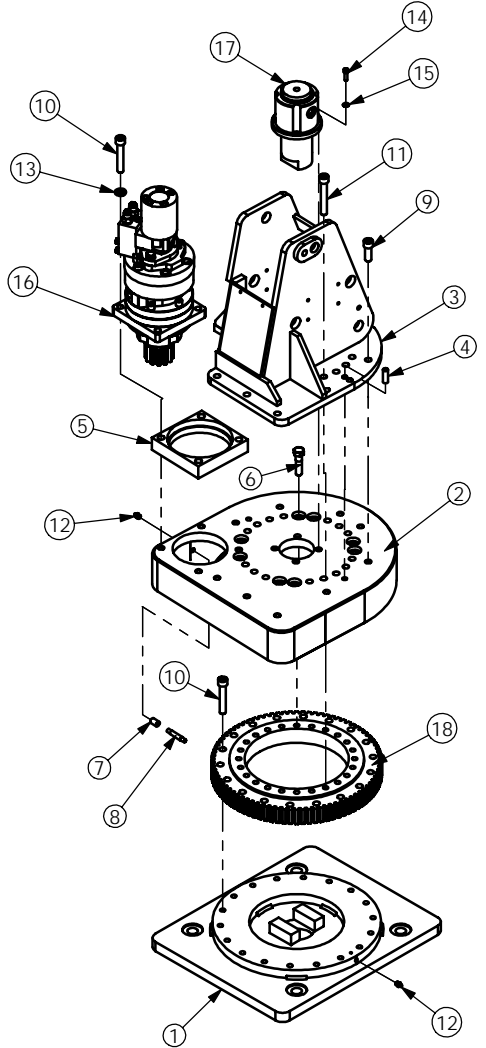

| ITEM # | QTY | PART # | DESCRIPTION |
|--------|-----|---------------|--------------------------------|
| 1 | 1 | STI680122 | BASE, CRANE, 8K |
| 2 | 1 | STI680123 | HOUSING, GEAR, ROTATE |
| 3 | 1 | STI680131 | TURRET, 8K, WLD |
| 4 | 2 | STI700043 | PIN, DOWEL, METAL, .5, 1.5 |
| 5 | 1 | STI610339 | MOUNT, DRIVE, ROTATE |
| 6 | 8 | BLT58X212NCML | BLT, HEX, 5/8, 2-1/2, NC, G8 |
| 7 | 1 | PFBL18COU | COUP, 1/8, BLK |
| 8 | 1 | PFBL18X212NIP | NIPPLE, 1/8, 2-1/2, BLK |
| 9 | 9 | SPDHB58X134NC | BLT, SHCS, 5/8, 1-3/4, NC |
| 10 | 22 | SPDHB58X312NC | BLT, SHCS, 5/8, 3-1/2, NC |
| 11 | 15 | SPDHB58X4NC | BLT, SHCS, 5/8, 4, NC |
| 12 | 2 | SPGZRK610 | ZRK, GRS, 1/8, MALE, PIPE, STR |
| 13 | 4 | WSH58LOCK | WSH, LOCK, 5/8 |
| 14 | 4 | SPDHB516X1 | BLT, SHCS, 5/16, 1, NC |
| 15 | 4 | WSH516LOCK | WSH, LOCK, 5/16 |
| 16 | 1 | STI680139 | ROTATE, 8K, ASSY |
| 17 | 1 | STI680124 | CONN, ROTATE, 8K, 10K, ASSY |
| 18 | 1 | STI700000 | RING, SLEWING, 8K, MACHINED |

| | | | |
|--|------------------------------|---|-----------------------|
| DRAWN RMP | DATE 5-99 | PROPERTY OF SERVICE TRUCKS INTERNATIONAL A DIVISION OF SIOUX AUTOMATION CENTER INC. 877 FIRST AVE NW SIOUX CENTER, IA 51250 | |
| CHECKED | DATE | TURRET, 8K, ASSY | |
| SCALE 1:12 | BREAK ALL EDGES .03 X 45° | | |
| DIMENSIONS ARE IN INCHES TOLERANCES UNLESS SPECIFIED FRACTIONAL ± 1/32 3 PLACE ± .005 2 PLACE ± .020 ANGULAR ± 1° | | SIZE B | DWG NO. STI691802 |
| MATERIAL AS NOTED | | | REV D SHEET 1 OF 1 |

DWG. NO. STI691803
DO NOT SCALE DRAWING

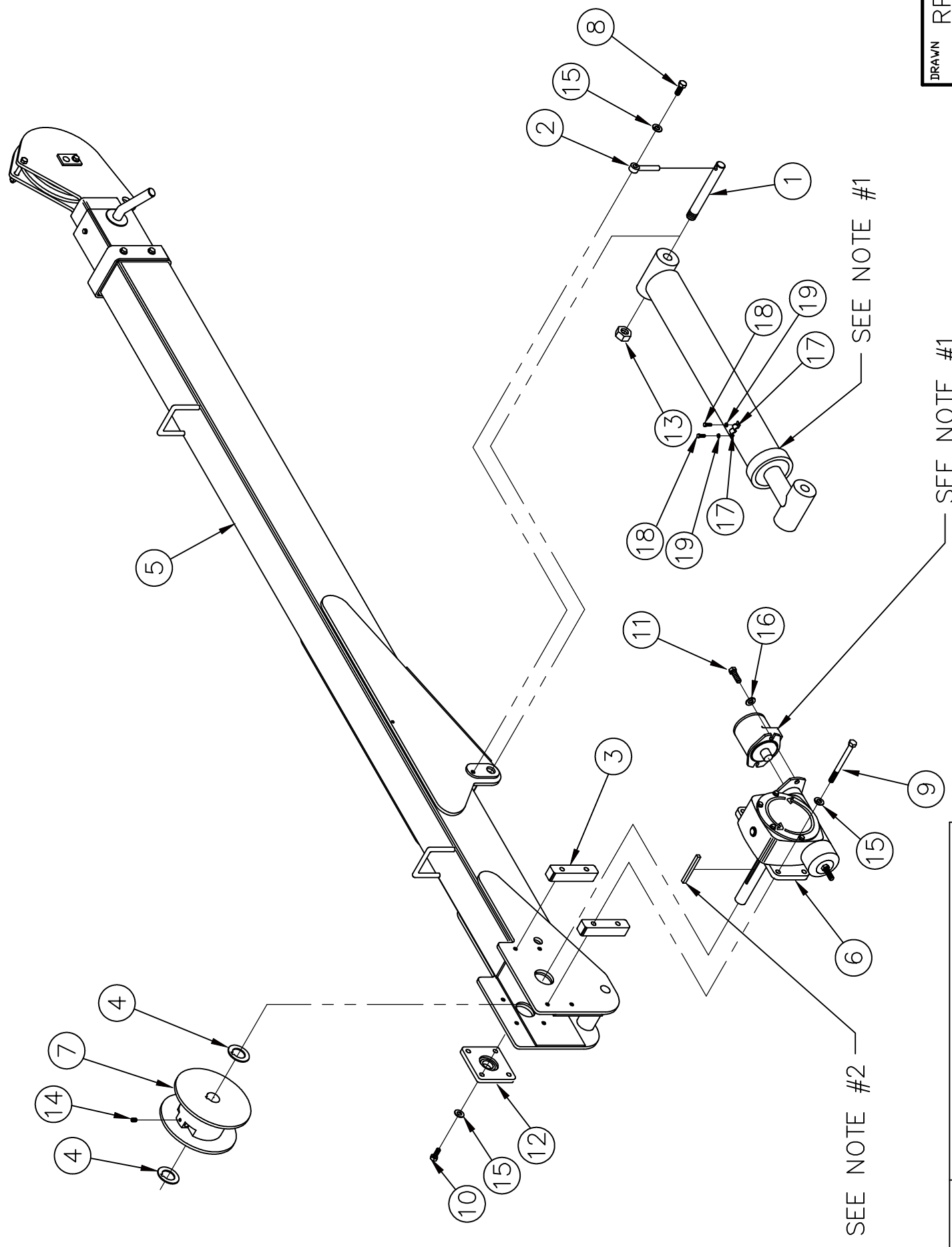

NOTE:
1.) PART NUMBER FOR LIFT CYL. & WINCH MOTOR IS ON HYD. PRINT #STI\691812.
2.) REPLACEMENT PART FOR 3/8x3/8 KEYSTOCK (4.00 LONG) IS KEY38X38

| REVISIONS | | | | REV | E |
|-----------|-----|--|-------|-----|-----|
| ECN | REV | DESCRIPTION | DATE | BY | CHK |
| 1635 | A | ADD OPTIONS & LEVEL INFO | 4-02 | CAS | |
| 1950 | B | CHG: STI610419 WAS STI610207 | 12-02 | JGS | |
| 2160 | C | REMOVED ATB FROM OPTIONS | 5-03 | JGS | |
| 3413 | D | DEL: STI700375-1, ADD: STI680251 | 2-05 | SZ | |
| 5745 | E | DEL: STI610419 QTY 1, ADD: STI610207 QTY 1 | 12-08 | SZ | |

| L | 19 | WSH14LOCK | 4 | WSH,LOCK,1/4 | |
|--------|-----|--------------|----------|------------------------------|-------------|
| L | 18 | BLT14X12NC | 2 | BLT,HEX,1/4,1/2,NC,G5 | |
| L | 17 | STI700330 | 2 | CLAMP,CONDUIT | |
| L | 16 | WSH716LOCK | 2 | WSH,LOCK,7/16 | |
| L | 15 | WSH12LOCK | 11 | WSH,LOCK,1/2 | |
| L | 14 | SPASNC38X12 | 1 | SCREW,ALLEN,3/8,1/2,NC | |
| L | 13 | NUT118JAMLNF | 1 | NUT,JAM,NYLOCK,1-1/8,NF,G8 | |
| L | 12 | BRGFC425114 | 1 | BRG,FLG,4BLT,1.25 | |
| L | 11 | BLT716X114NC | 2 | BLT,HEX,7/16,1-1/4,NC,G5 | |
| L | 10 | BLT12X114NC | 6 | BLT,HEX,1/2,1-1/4,NC,G5 | |
| L | 9 | BLT12X5NC | 4 | BLT,HEX,1/2,5,NC,G5 | |
| L | 8 | BLT12X1NC | 1 | BLT,HEX,1/2,1,NC,G5 | |
| L | 7 | STI680251 | 1 | SPOOL,CABLE,WINCH,8K,6K,ASSY | |
| L | 6 | STI700028 | 1 | WINCH,CABLE,6K,8K | |
| L | 5 | STI691801 | 1 | BOOM,ASSY,#2 (REF) | |
| L | 4 | STI610265 | 2 | SPACER,3.5,2,1,NYL | |
| L | 3 | STI610263 | 2 | SPACER,WINCH,6K,8K | |
| L | 2 | STI610207 | 1 | PIN,ROD,EYE,3.75 | |
| L | 1 | STI610113 | 1 | PIN,BOOM,1.12,8.34 | |
| OPTION | LVL | ITEM | PART NO. | QTY. | DESCRIPTION |

| | | | |
|----------------------------------|---|-----------------|-----------|
| DRAWN | RPM | DATE | 4-99 |
| CHECKED | | DATE | |
| SCALE | 1:18 | BREAK ALL EDGES | .03 X 45° |
| DIMENSIONS ARE IN INCHES | | | |
| TOLERANCES UNLESS SPECIFIED | | | |
| FRACTIONAL ± 1/32 3 PLACE ± .005 | | | |
| 2 PLACE ± .020 ANGULAR ± 1° | | | |
| MATERIAL AS NOTED | | | |
| PROPERTY OF | SERVICE TRUCKS INTERNATIONAL | | |
| | A DIVISION OF SIOUX AUTOMATION CENTER, INC. | | |
| | 877 FIRST AVE NW SIOUX CENTER, IOWA 51250 | | |
| BOOM, 8K, ASSY, #2 | | | |
| SIZE | B | DWG NO. | STI691803 |
| REV | | | E |

| OPTION | DESCRIPTION |
|--------|-----------------------|
| B | 2 FT EXTENDED BOOM |
| C | 4 FT EXTENDED BOOM |
| D | PROPORTIONAL CONTROLS |
| E | STAINLESS STEEL CABLE |
| F | OVERLOAD PROTECTION |
| | STANDARD EQUIPMENT |

DWG. NO. STI691804

DO NOT SCALE DRAWING

| OPTION | DESCRIPTION |
|--------|-----------------------|
| B | 2 FT EXTENDED BOOM |
| C | 4 FT EXTENDED BOOM |
| D | PROPORTIONAL CONTROLS |
| E | STAINLESS STEEL CABLE |
| F | OVERLOAD PROTECTION |
| | STANDARD EQUIPMENT |

NOTE:
 1.) PART NUMBER FOR VALVE ARE ON HYD. PRINT #STI\691812

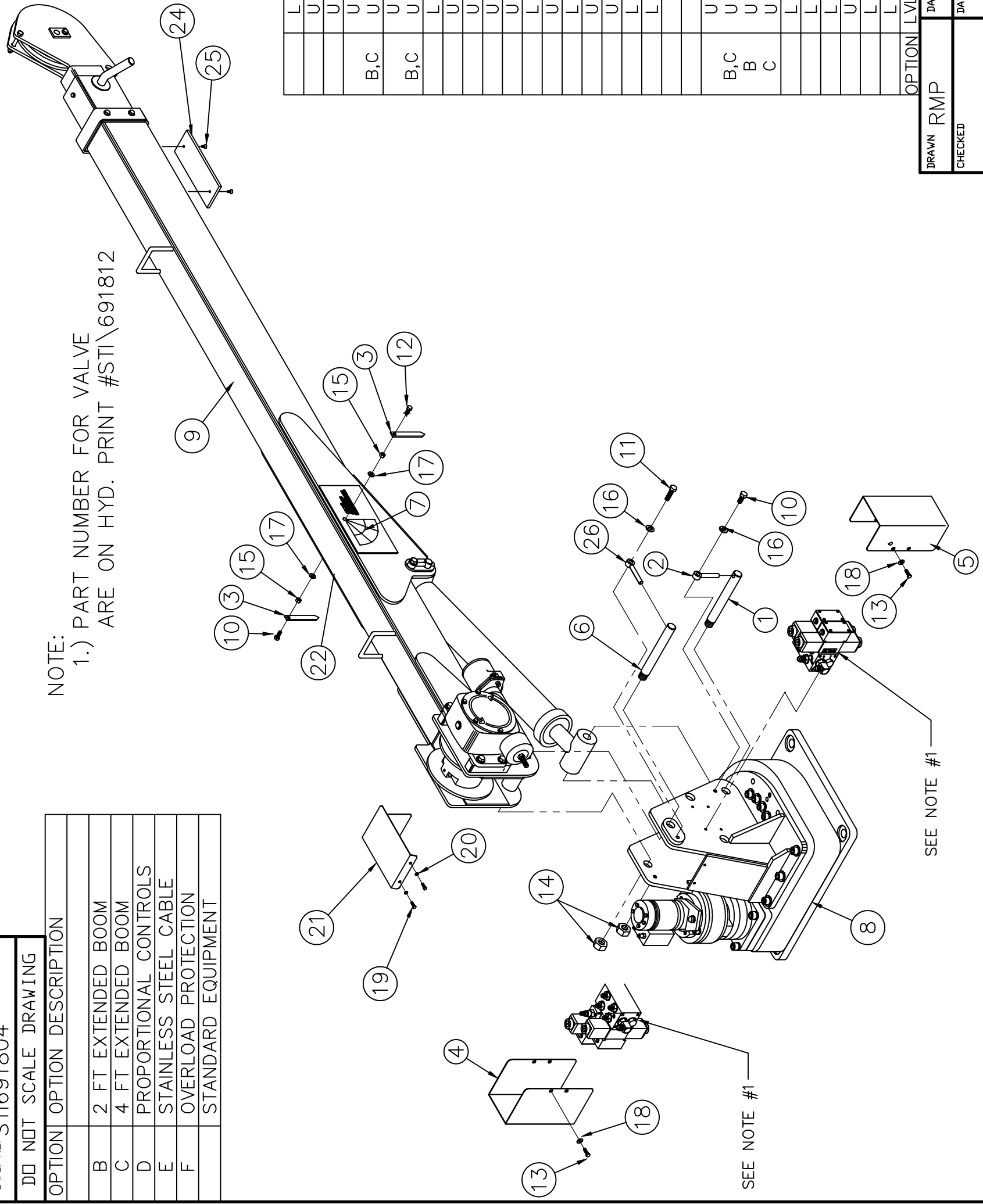

| REVISIONS | | | | |
|-----------|-----|--|-------|-----|
| ECN | REV | DESCRIPTION | DATE | BY |
| 1635 | A | ADD OPTIONS & LEVEL INFO | 4-02 | CAS |
| 1853 | B | SEE ECN FOR CHANGES | 9-02 | AP |
| 2007 | C | ADDED PAD, SNATCHBLOCK | 2-03 | JGS |
| 2160 | D | DEL ATB OPTION | 7-03 | JGS |
| 5745 | E | ADD: STI610419 QTY 1, CHG: STI610207 QTY 1 WAS 2 | 12-08 | SZ |

| L | U | B,C | B | C | | | | | |
|----|---|-----|---|---|-----------------------------|----|-------------------------------------|--|--|
| 26 | | | | | STI610419 | 1 | PIN, ROD, EYE, 2.88 | | |
| 25 | | | | | BLT, FLT, 1/4, 1/2, NC, GR2 | 2 | | | |
| 24 | | | | | STI610421 | 1 | PAD, SNATCHBLOCK | | |
| 23 | | B,C | | | STI701187 | 1 | PLATE, NUMBER, SERIAL, CRANE | | |
| 22 | | B,C | | | STI701186 | -1 | PLATE, NUMBER, SERIAL, CRANE | | |
| 21 | | | | | STI701187 | 1 | DECAL, IND, ANGLE, CRANE, VINYL, RH | | |
| 20 | | | | | STI511325 | -1 | DECAL, IND, ANGLE, CRANE, VINYL, RH | | |
| 19 | | | | | WSH14LOCK | 1 | SHIELD, 8K, TURRET | | |
| 18 | | | | | BLT14x12NC | 2 | WSH, LOCK, 1/4 | | |
| 17 | | | | | WSH14FLAT | 2 | BLT, HEX, 1/4, 1/2, NC, G5 | | |
| 16 | | | | | WSH38LOCK | 8 | WSH, FLAT, 1/4 | | |
| 15 | | | | | WSH12LOCK | 2 | WSH, LOCK, 3/8 | | |
| 14 | | | | | NUT38NC | 2 | WSH, LOCK, 1/2 | | |
| 13 | | | | | NUT118JAMLNF | 2 | NUT, HEX, 3/8, NC, G5 | | |
| 12 | | | | | BLT516X12NC | 2 | NUT, NYLOCK, JAM, 1-1/8, NF, G8 | | |
| 11 | | | | | BLT38X1NC | 8 | BLT, HEX, 5/16, 1/2, NC, G5 | | |
| 10 | | | | | BLT12X112NC | 2 | BLT, HEX, 3/8, 1, NC, G5 | | |
| 9 | | | | | BLT12X1NC | 1 | BLT, HEX, 1/2, 1-1/2, NC, G5 | | |
| 8 | | | | | STI691803 | 1 | BLT, HEX, 1/2, 1, NC, G5 | | |
| 7 | | B,C | | | STI691802 | 1 | BOOM, 8K, ASSY, #2 (REF) | | |
| 6 | | | | | STI701208 | 1 | TURRET, 8K, ASSY (REF) | | |
| 5 | | | | | STI701208 | 1 | DECAL, IND, ANGLE, CRANE, VINYL, LH | | |
| 4 | | | | | STI700393 | -1 | DECAL, IND, ANGLE, CRANE, VINYL, LH | | |
| 3 | | | | | STI700583 | 1 | CHART, LOAD, ALUM, 8K-24, PAIR | | |
| 2 | | | | | STI610409 | 1 | CHART, LOAD, ALUM, 8K-48, PAIR | | |
| 1 | | | | | STI610334 | 1 | PIN, TURRET, 1.12, 10.03 | | |
| | | | | | STI610333 | 1 | GUARD, VALVE, 5.25, 4.56 | | |
| | | | | | STI610267 | 2 | COVER, VALVE, 5.25, 6.25 | | |
| | | | | | STI610207 | 1 | INDCTR, ANGLE, 5.5 | | |
| | | | | | STI610112 | 2 | PIN, ROD, EYE, 3.75 | | |
| | | | | | | 2 | PIN, TURRET, 1.125, 9.03 | | |

| | | | |
|----------------------------------|---|-----------------|-----------|
| DRAWN | RMP | DATE | 5-99 |
| CHECKED | | DATE | |
| SCALE | 1:18 | BREAK ALL EDGES | .03 X 45° |
| DIMENSIONS ARE IN INCHES | | | |
| TOLERANCES UNLESS SPECIFIED | | | |
| FRACTIONAL ± 1/32 3 PLACE ± .005 | | | |
| 2 PLACE ± .020 ANGULAR ± 1° | | | |
| MATERIAL | | | |
| AS NOTED | | | |
| PROPERTY OF | SERVICE TRUCKS INTERNATIONAL | | |
| | A DIVISION OF SIOUX AUTOMATION CENTER, INC. | | |
| | 877 FIRST AVE NW SIOUX CENTER, IOWA 51250 | | |
| SIZE | B | DWG NO. | STI691804 |
| REV | E | | |



DWG. NO. ST1691805

| DD NOT | SCALE | DRAWING |
|--------|-----------------------|-------------|
| OPTION | OPTION | DESCRIPTION |
| B | 2 FT EXTENDED BOOM | |
| C | 4 FT EXTENDED BOOM | |
| D | PROPORTIONAL CONTROLS | |
| E | STAINLESS STEEL CABLE | |
| F | OVERLOAD PROTECTION | |
| | STANDARD EQUIPMENT | |

NOTE:
 1.) PRESSURE SWITCH LOCATED ON BASE OF CYLINDER.
 2.) SEE ST1691813 FOR WIRING DIAGRAM.

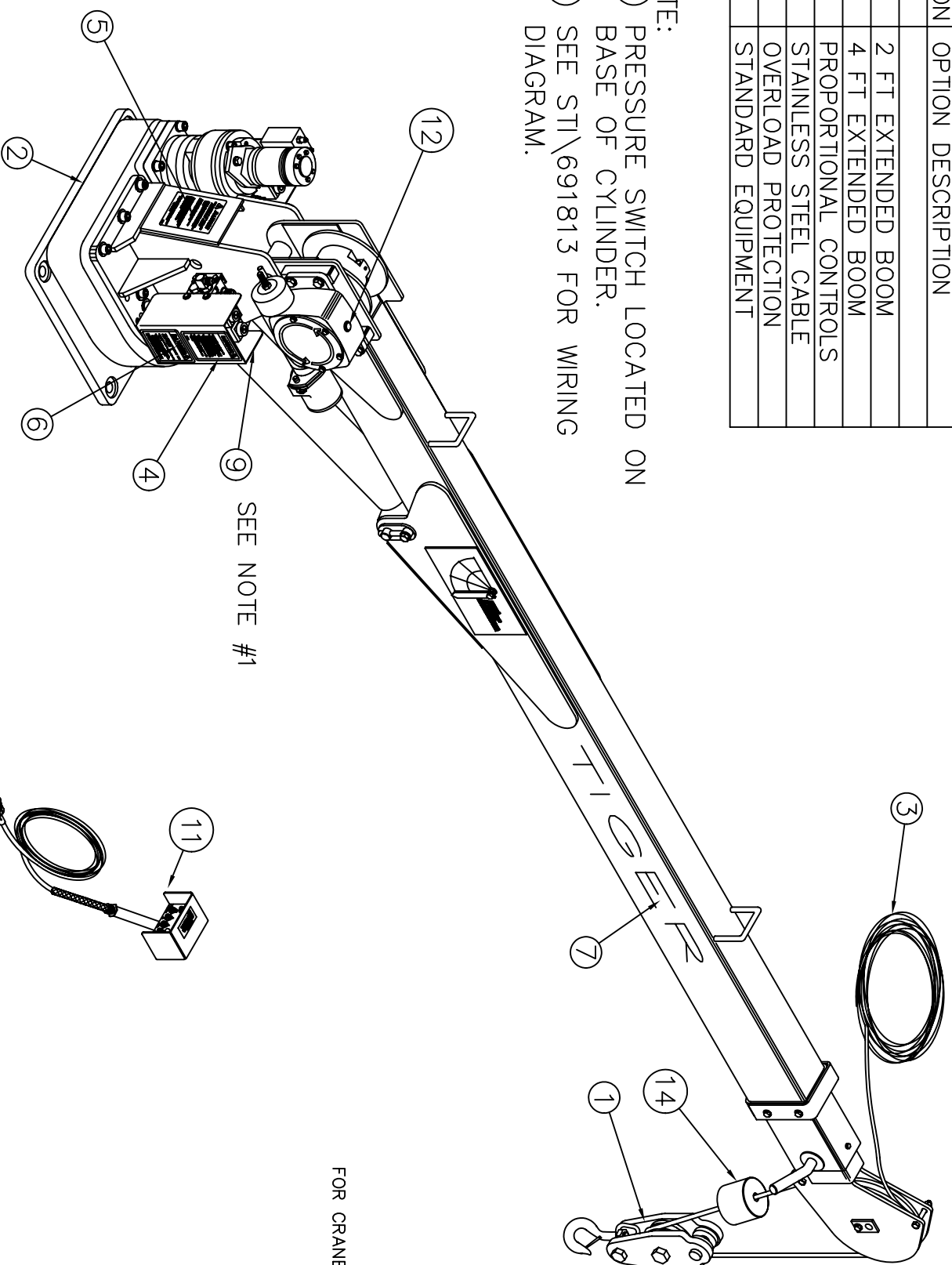

SEE NOTE #2

SEE NOTE #1

FOR CRANE TOWER

ONE FOR CRANE TOWER

| REVISIONS | | | | REV | H |
|-----------|-----|---|------|-----|-----|
| ECN | REV | DESCRIPTION | DATE | BY | CHK |
| 2160 | G | ADDED ATB & SNATCHBLOCK | 5-03 | JGS | |
| 3468 | H | ADD: ST1700568 QTY 1, BLT14X34 QTY 2, WSH14LOCK QTY 2 | 3-05 | SZ | |

| | | | | | |
|--------|-----|------|---------------|------|------------------------------------|
| TIGER | U | NS | ST1701192 | 4 | COVER, OVERRIDE, MAN. VALVE, D03 |
| TIGER | U | NS | WSH12FLAT | 6 | WSH, FLAT, 1/2 |
| TIGER | U | NS | BLT12X6LAG | 2 | BLT, LAG, HEX, 1/2, 6 |
| TIGER | U | NS | BLT12X4LAG | 4 | BLT, LAG, HEX, 1/2, 4 |
| TIGER | U | NS | ST1691938 | 1 | SKID, SHIPPING, 8K, COVER, ASSY |
| D | U | NS | ST1610394 | 1 | MANUAL, CONTROL, PROPORTIONAL |
| | U | NS | ST1610392 | 1 | MANUAL, CRANE, 8000 |
| | L | NS | SPCABLETIEHVV | 30 | TIE, CABLE, HVY, #175 |
| | L | NS | SPCABLETIEMED | 30 | TIE, CABLE, MED, #30-50 |
| | L | NS | ST12SHRINK | 34 | TUBING, SHRINK, HEAT, .5 |
| | L | NS | ST14SHRINK | 12 | TUBING, SHRINK, HEAT, .25 |
| | L | NS | ST134SHRINK | 4 | TUBING, SHRINK, HEAT, .75 |
| | L | NS | ST1700279 | 8 | TRMNL, RING, INSLTD, ST, ALL |
| | L | NS | ST1700254 | 12 | CONN, WIRE, PL, HARD |
| TIGER | U | NS | ST1700228 | 1 | RELAY, SPD, 12VDC |
| | L | NS | ST1700221 | 24 | OIL, HYD, MOBIL |
| | L | NS | WSH14LOCK | 1 | WSH, LOCK, 1/4 |
| | L | NS | BLT14X34NC | 2 | BLT, 1/4, 3/4, NC, G5 |
| | L | NS | ST1700568 | 1 | MOUNT, AMPH, RCP TCL |
| | U | NS | ST1680173 | 1 | SWTCH, ANTI-2 BLOCK, ASSY |
| B, C | U | NS | ST1400086 | 1 | DECAL, CHART, LOAD, 8K |
| B | U | NS | ST1400086 | -1 | DECAL, CHART, LOAD, 8K |
| C | U | NS | ST1400095 | 1 | DECAL, CHART, LOAD, 8K-24 |
| | L | NS | ST1400122 | 1 | DECAL, CHART, LOAD, 8K-48 |
| | L | NS | OL85W140 | 2 | OIL, 85W140 |
| D | U | NS | ST1680043 | 1 | REMOTE, HYD, 25', AMPHNL, UNLDR |
| D | U | NS | ST1680043 | -1 | REMOTE, HYD, 25', AMPHNL, UNLDR |
| D | L | NS | ST1680042 | 1 | REMOTE, HYD, 25', AMP, PROPR TNL |
| D | L | NS | ST1680044 | 1 | HARNSS, WIRE, HYD, 10K, 8K, AMPHNL |
| D | L | NS | ST1680044 | -1 | HARNSS, WIRE, HYD, 10K, 8K, AMPHNL |
| D | L | NS | ST1680056 | 1 | HARNSS, WIRE, HYD, 8K, AMP |
| D | L | NS | ST1680113 | 1 | BOX, CNTRL, PROPR TNL, ENCLCSURE |
| | L | NS | ST1700390 | 1 | SWTCH, PRES, 2800PSI |
| TIGER | U | NS | ST1700135 | 1 | BOX, CRDBRD, 12, 10, 10 |
| TIGER | U | NS | ST1700074 | 2 | DECAL, ST, 2K, 3.5K, 6K, 8K |
| TIGER | U | NS | ST1700072 | 2 | DECAL, TIGER, 2K, 3.5K, 6K, 8K |
| | U | NS | ST1700066 | 2 | DECAL, OPERATE, CRANE, DANGER |
| | U | NS | ST1700065 | 2 | DECAL, HAZARD, ELEC, DANGER |
| | U | NS | ST1700064 | 2 | DECAL, INSTRCTN, CAUTION |
| | U | NS | ST1700008 | 1 | ROPE, WIRE, .38, 900' |
| | U | NS | ST1691804 | 1 | TURRET, BOOM, 8K, ASSY (REF) |
| | U | NS | ST1691947 | 1 | BLOCK, SNATCH, 8K, ASSY |
| OPTION | LVL | ITEM | PART NO. | QTY. | DESCRIPTION |

PROPERTY OF SERVICE TRUCKS INTERNATIONAL
 A DIVISION OF SIOUX AUTOMATION CENTER, INC.
 877 FIRST AVE NW SIOUX CENTER, IOWA 51250

CRANE, 8K, ASSY, FINAL

| | | | |
|--|------|-----------------|-----------|
| DRAWN | RMP | DATE | 5-99 |
| CHECKED | | DATE | |
| SCALE | 1:18 | BREAK ALL EDGES | .03 X 45° |
| DIMENSIONS ARE IN INCHES TOLERANCES UNLESS SPECIFIED FRACTIONAL ± 1/32 2 PLACE ± .020 ANGULAR ± 1° | | | |
| MATERIAL AS NOTED | | | |

| | | |
|------|-----------|-----|
| SIZE | DWG NO. | REV |
| B | ST1691805 | H |

DWG NO. STI680043
DO NOT SCALE DRAWING

| REVISIONS | | | | | |
|-----------|------|---|------|-----|----|
| ECN | REV. | DESCRIPTION | DATE | BY | CK |
| | A | STI1814CNTRL WAS STI1812CNTRL | 6-99 | HW | |
| 988 | B | STI700291 QTY WAS 26 | 3-01 | CAS | |
| 1556 | C | STI680057 WAS COMPONENTS | 3-02 | BPL | |
| 1633 | D | SEE ECN FOR CHANGES | 4-02 | BJL | |
| 3618 | E | CHG: REVISED FUNCTION POSITIONS, STI700291 QTY WAS 23 | 6-05 | SZ | |

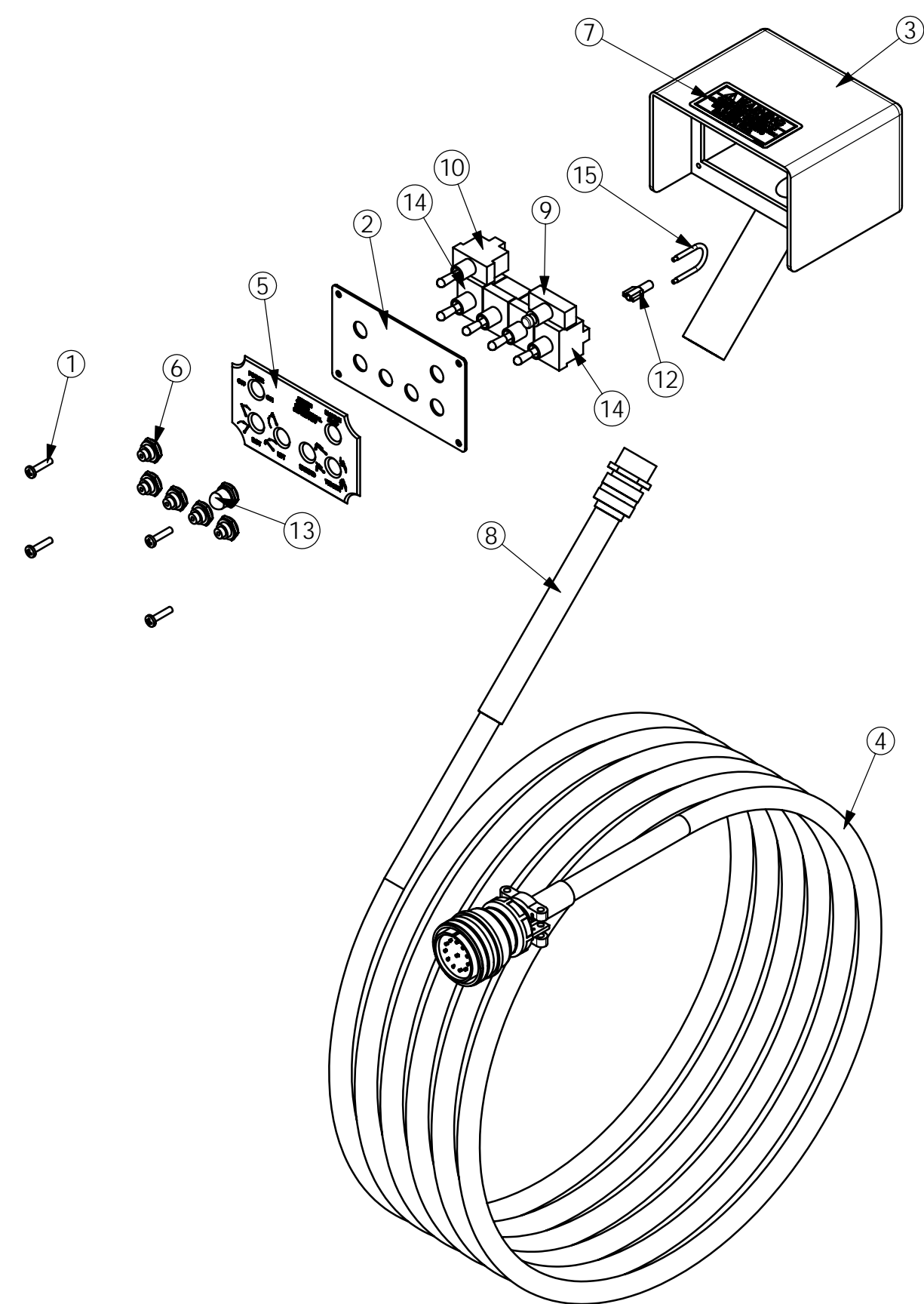

NOTE:
1) ITEM #12 ARE USED TO CONNECT CONTROL CABLE TO PUSH BUTTON AND ITEM #13 ARE USED TO CONNECT CONTROL CABLE TO TOGGLE SWITCHES.
2) ITEM #15 ARE USED TO MAKE JUMPER WIRES INSIDE OF BOX.

| ITEM # | QTY | PART # | DESCRIPTION |
|--------|-----|-----------------|-----------------------------------|
| 1 | 4 | SPMB832X34SSP | SCREW, MACH, 8-32, 3/4, SS |
| 2 | 1 | STI100156 | COVER, BOX, CNTRL, ELEC |
| 3 | 1 | STI200109 | BOX, CNTRL, ELEC |
| 4 | 1 | STI680164 | CORD, REMOTE, HYD, 300", AMPHNL |
| 5 | 1 | STI700140 | DECAL, FACE, CNTRL, REMOTE, HYD |
| 6 | 5 | STI700155 | BOOT, RUBBER |
| 7 | 1 | STI700176 | DECAL, WARNING, CONT, ROTATE |
| 8 | 1 | STI700188 | GRIP, CORD, DELUXE, CNTRL, REMOTE |
| 9 | 1 | STI700189 | SWITCH, BUTTON, PUSH |
| 10 | 1 | STI700250 | SWITCH, TOGGLE, 2-WAY, SPADE |
| 11 | 2 | STI700279 | TRMNL, RING, INSLTD, STI, ALL |
| 12 | 26 | STI700291 | TRMNL, PUSHON, STI, ALL |
| 13 | 1 | STI700346 | BOOT, RUBBER |
| 14 | 4 | STI700366 | SWITCH, TOGGLE, MOM, DPDT, SPADE |
| 15 | 24 | STI WIRE 18PRBL | WIRE, PRIMARY, 18GA, BLK |

| | | |
|--|------------------------------|--|
| DRAWN BM | DATE 11-97 | PROPERTY OF SERVICE TRUCKS INTERNATIONAL A DIVISION OF SIOUX AUTOMATION CENTER INC. 877 FIRST AVE NW SIOUX CENTER, IA 51250 |
| CHECKED | DATE | |
| SCALE 1:4 | BREAK ALL EDGES .03 X 45° | REMOTE, HYD, 25', AMPHNL, UNLDR |
| DIMENSIONS ARE IN INCHES TOLERANCES UNLESS SPECIFIED FRACTIONAL ± 1/32 3 PLACE ± .005 2 PLACE ± .020 ANGULAR ± 1° | | |
| MATERIAL AS NOTED | SIZE B | DWG NO. STI680043 |
| | | REV E SHEET 1 OF 2 |

DWG NO. STI680043
DO NOT SCALE DRAWING

REV E

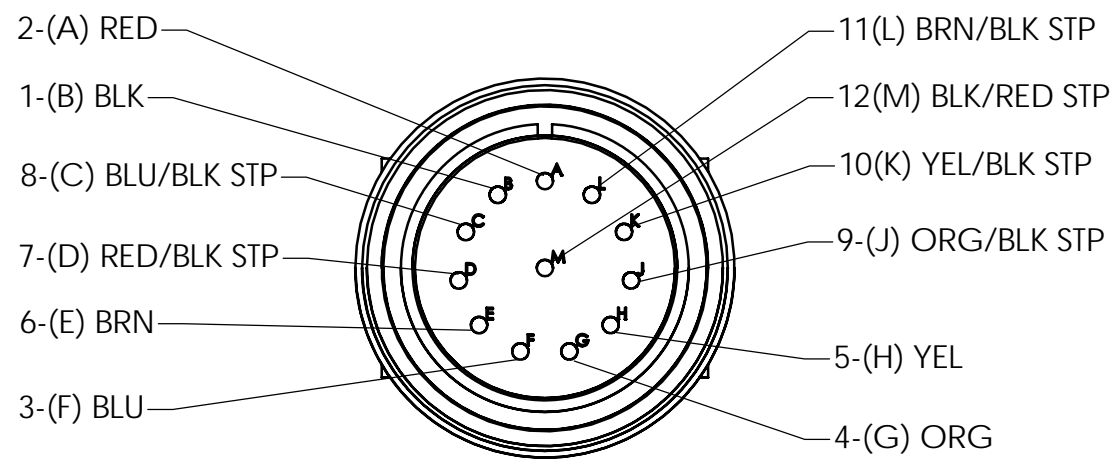

14-ORG/RED STP - SPARE
13-BLUE/RED STP - SPARE

NOTE:
3) "ON" SIDE OF POWER TOGGLE IS +12V POWER SUPPLY TO ALL OTHER SWITCHES.
4) PIN "M" IS ENERGIZED WHEN THE ROTATE, LIFT, WINCH, AND EXTEND SWITCHES ARE ACTIVATED IN EITHER DIRECTION.

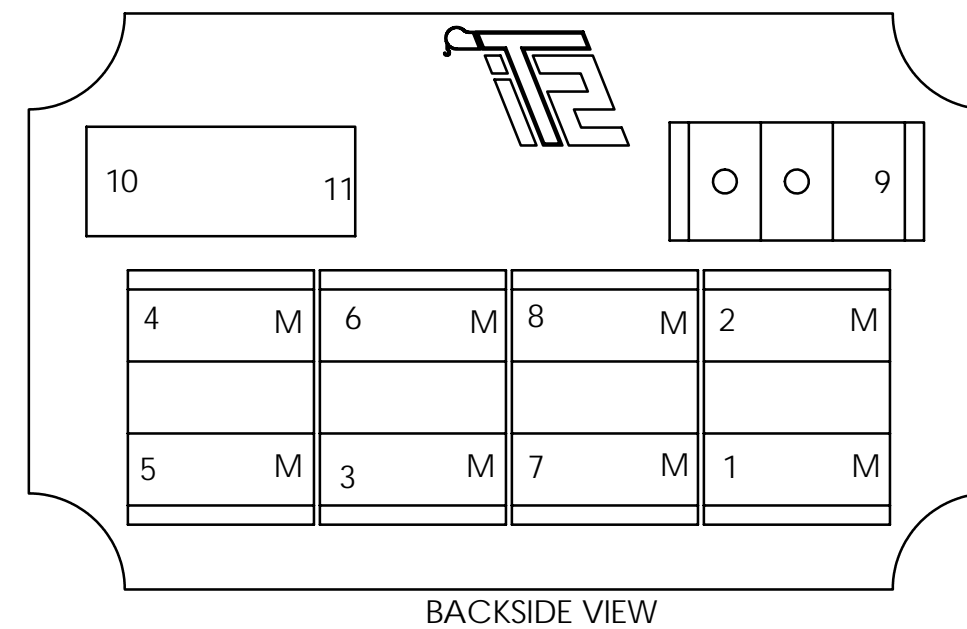
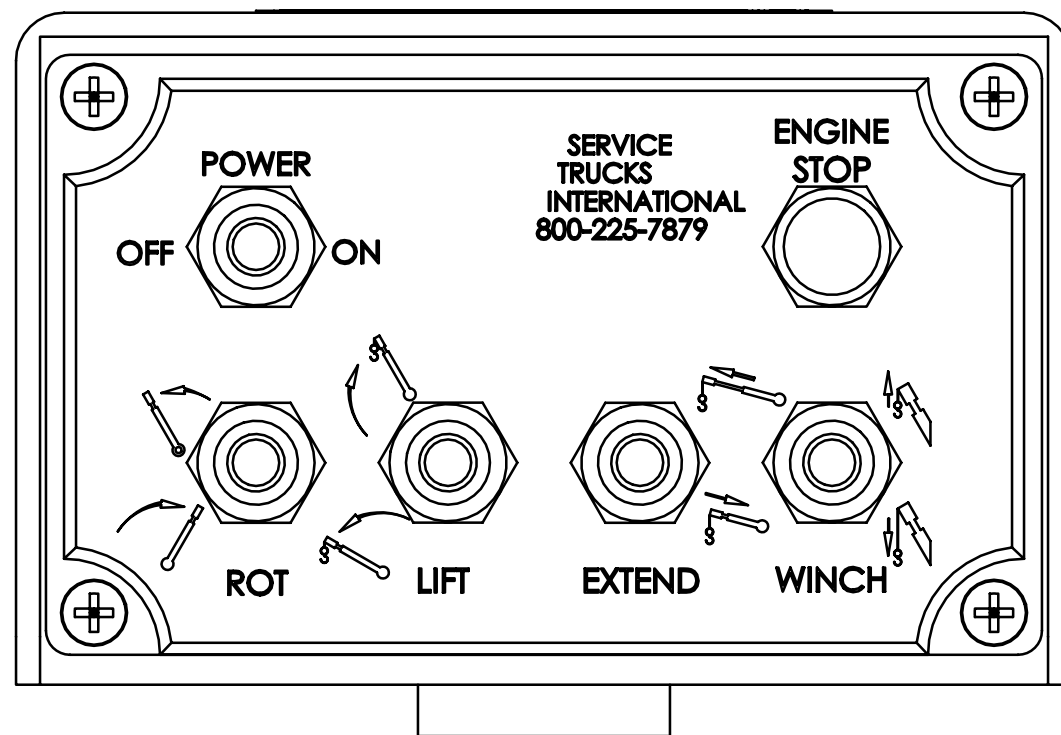

| | | | |
|--|------------------------------|---|----------------------|
| DRAWN BM | DATE 11-97 | PROPERTY OF SERVICE TRUCKS INTERNATIONAL A DIVISION OF SIOUX AUTOMATION CENTER INC 877 FIRST AVE NW SIOUX CENTER, IA 51250 | |
| CHECKED | DATE | REMOTE, HYD, 25', AMPHNL, UNLDR | |
| SCALE 1:1 | BREAK ALL EDGES .03 X 45° | | |
| DIMENSIONS ARE IN INCHES TOLERANCES UNLESS SPECIFIED FRACTIONAL ± 1/32 3 PLACE ± .005 2 PLACE ± .020 ANGULAR ± 1° | | SIZE B | DWG NO. STI680043 |
| MATERIAL AS NOTED | | REV E | SHEET 2 OF 2 |

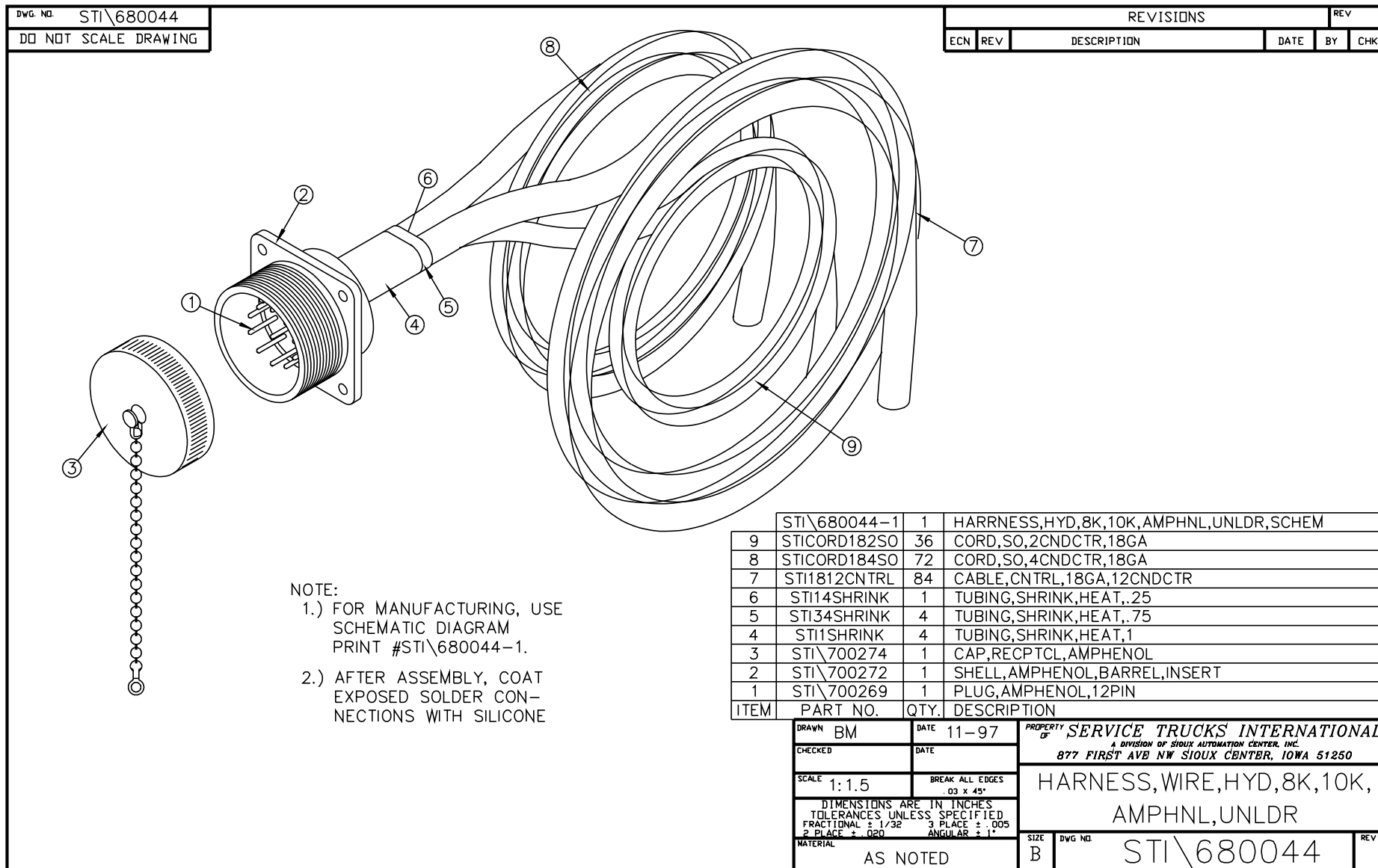

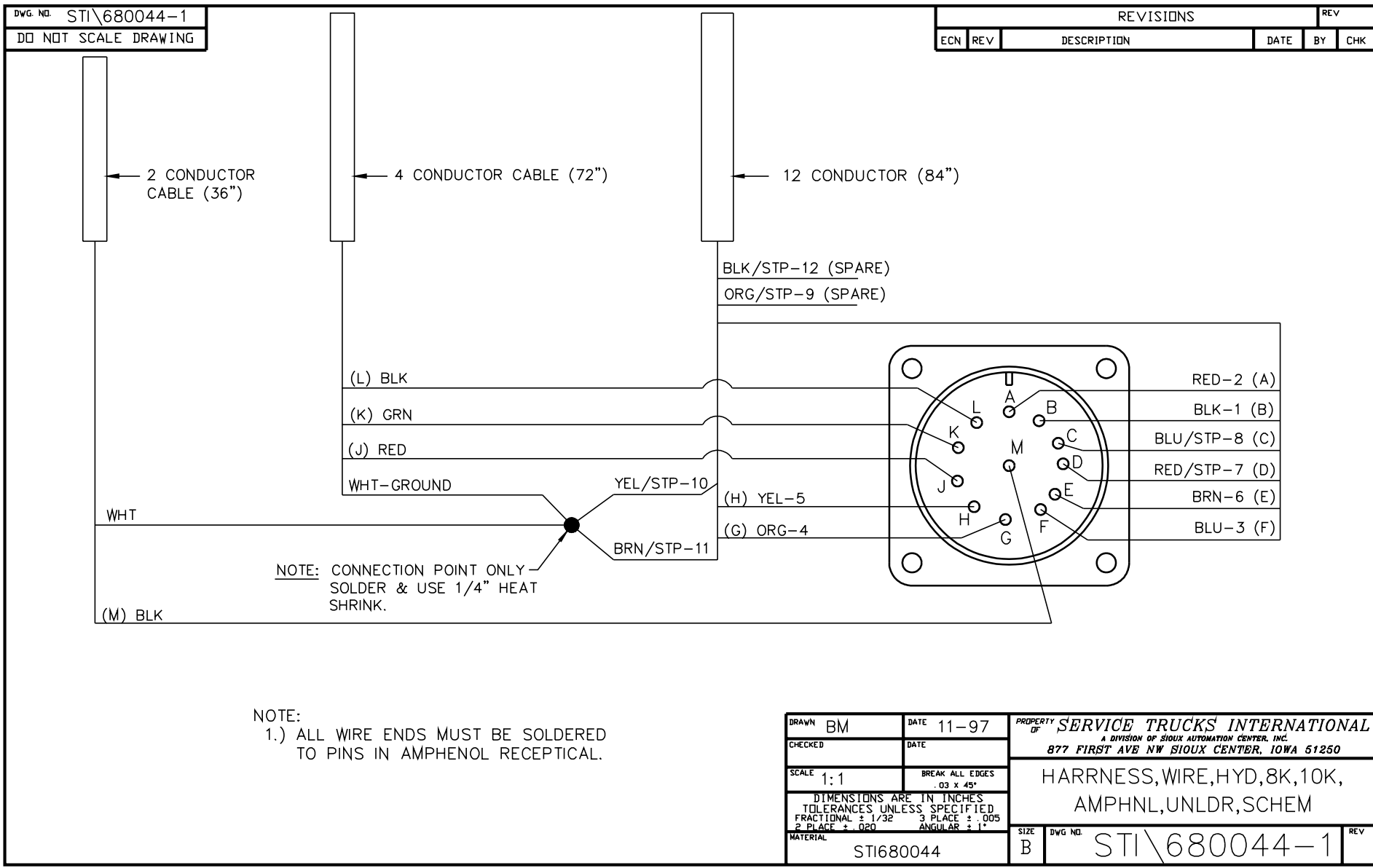

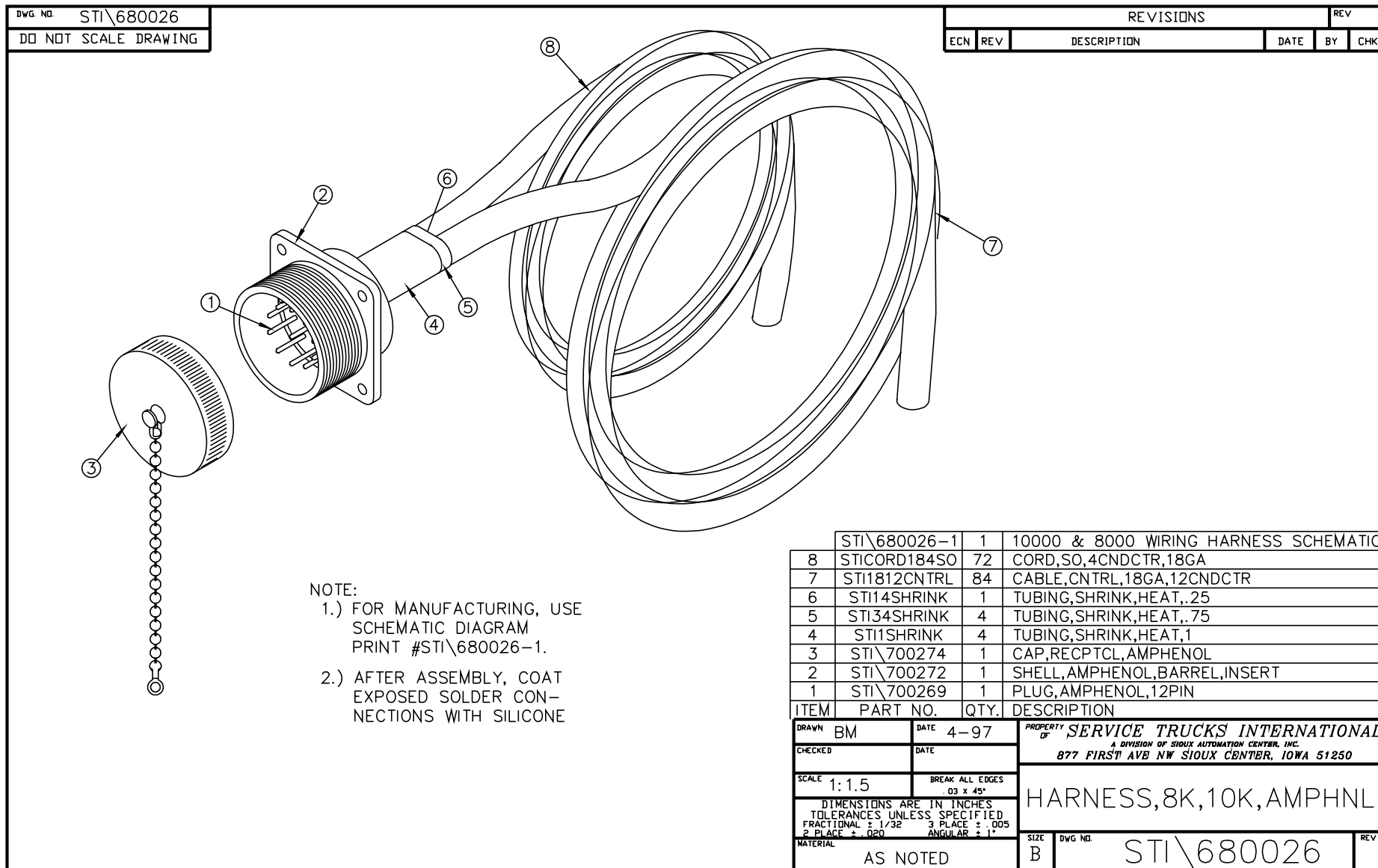

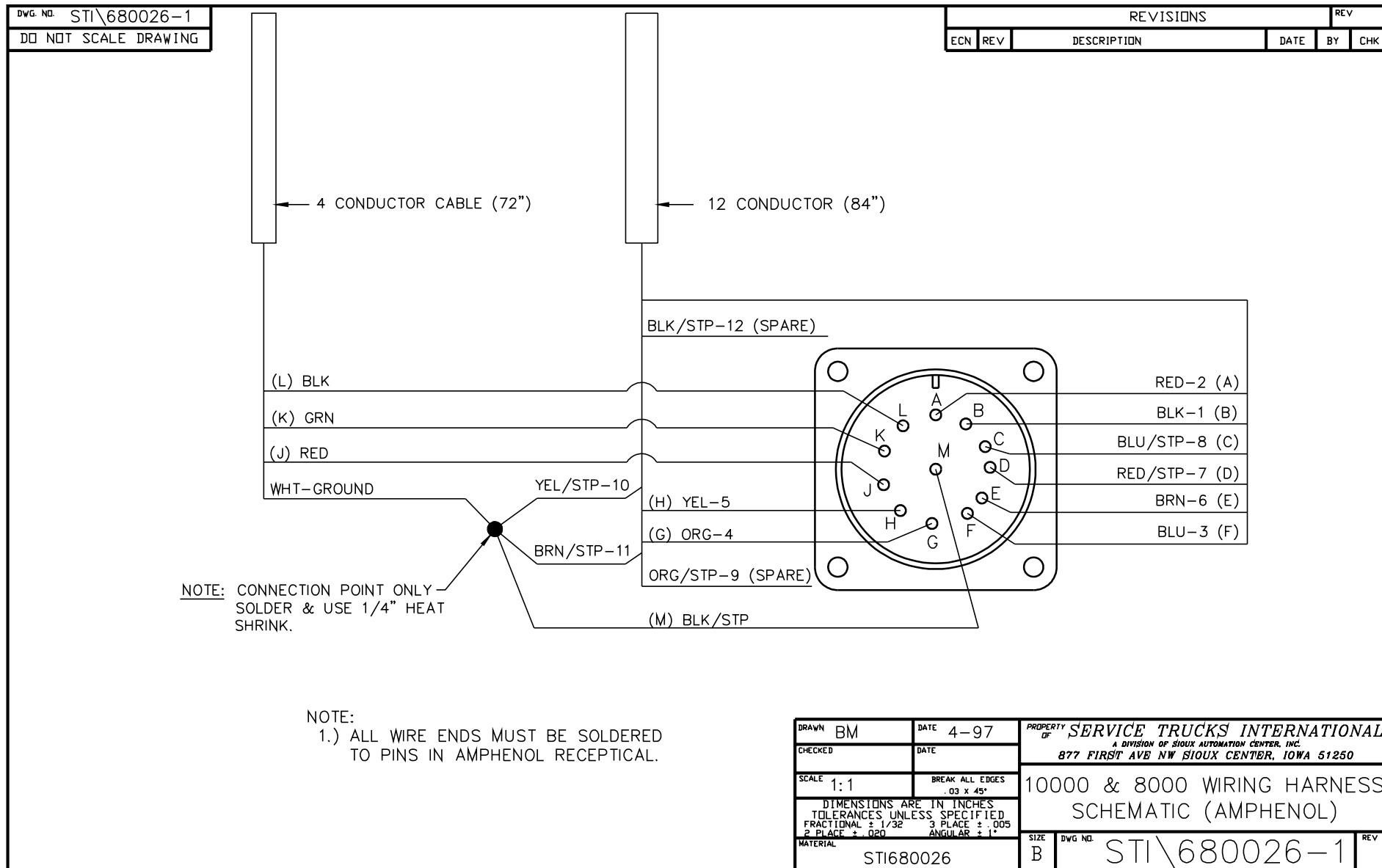

View thousands of Crane Specifications on FreeCraneSpecs.com

DWG. NO. STI\400100
DO NOT SCALE DRAWING

| REVISIONS | | | | | REV |
|-----------|-----|-------------|------|----|-----|
| ECN | REV | DESCRIPTION | DATE | BY | CHK |
| | | | | | |

NOTE: CONNECTION POINT ONLY. SOLDER & HEAT SHRINK.

NOTE: A PIN IS ENERGIZED WHEN ANY FUNCTION SWITCH IS ACTIVATED.

| | | |
|--|------------------------------|--|
| DRAWN RDK | DATE 5-95 | PROPERTY OF SERVICE TRUCKS INTERNATIONAL A DIVISION OF SIOUX AUTOMATION CENTER, INC. 877 FIRST AVE NW SIOUX CENTER, IOWA 51250 |
| CHECKED | DATE | 8000 AMPHENOL WIRING PICTORIAL |
| SCALE 1:1.25 | BREAK ALL EDGES .03 x 45° | |
| DIMENSIONS ARE IN INCHES TOLERANCES UNLESS SPECIFIED FRACTIONAL ± 1/32 PLACE ± .005 2 PLACE ± .020 ANGLE ± 1° | | |
| MATERIAL AS NOTED | SIZE B | DWG NO. STI\400100 |



DWG. NO. STI\691814
DO NOT SCALE DRAWING

| REVISIONS | | | | REV | |
|-----------|-----|-------------|------|-----|-----|
| ECN | REV | DESCRIPTION | DATE | BY | CHK |
| | | | | | |

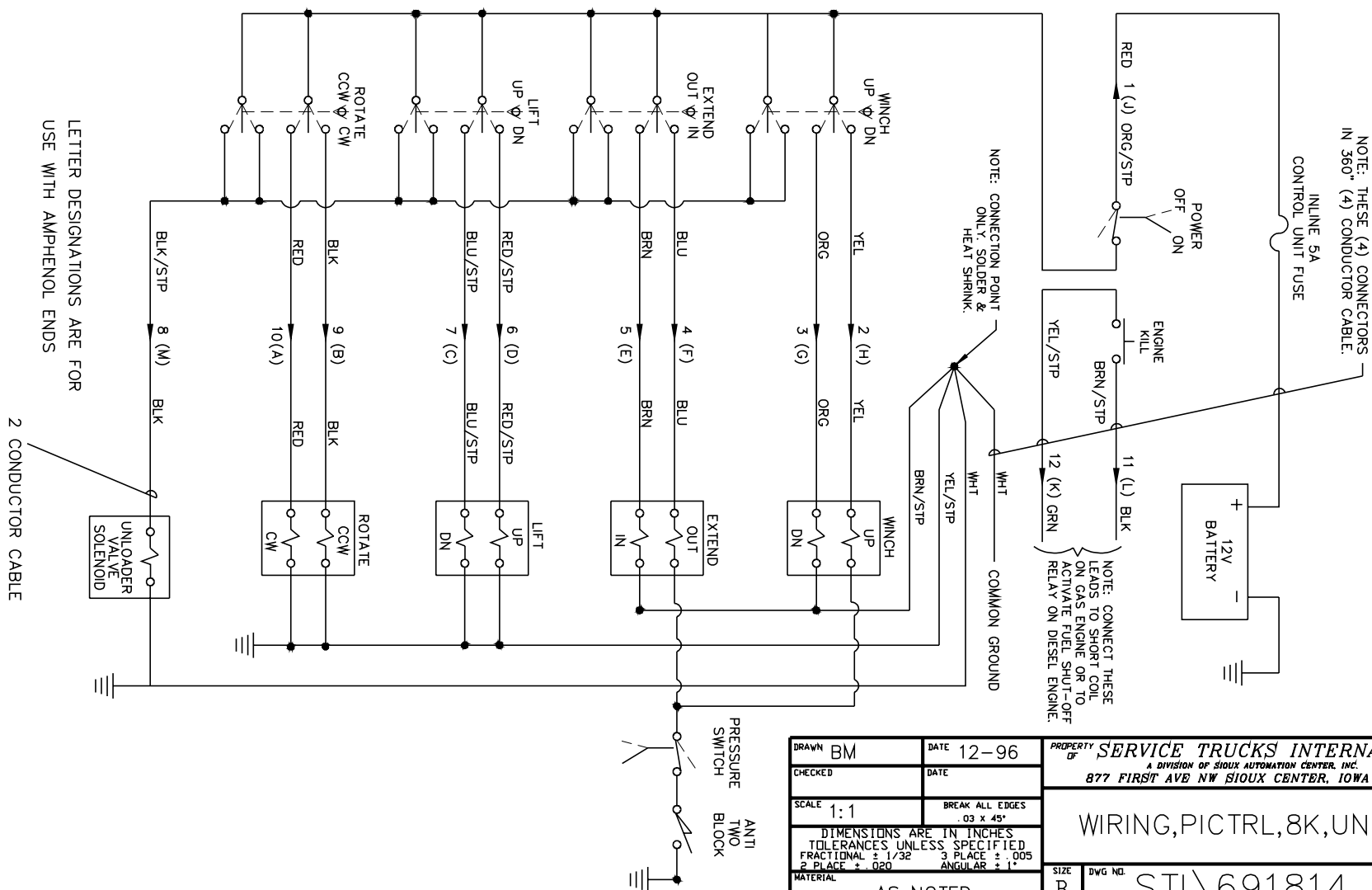

| | | | |
|--|----------|-----------------|-----------|
| DRAWN | BM | DATE | 12-96 |
| CHECKED | | DATE | |
| SCALE | 1:1 | BREAK ALL EDGES | .03 x 45° |
| DIMENSIONS ARE IN INCHES TOLERANCES UNLESS SPECIFIED | | | |
| FRACTIONAL ± 1/32 | | 3 PLACE ± .005 | |
| 2 PLACE ± .020 | | ANGULAR ± 1° | |
| MATERIAL | AS NOTED | | |

| | | | |
|---|---|----------|------------|
| PROPERTY OF SERVICE TRUCKS INTERNATIONAL | | REV | |
| A DIVISION OF SIOUX AUTOMATION CENTER, INC. | | | |
| 877 FIRST AVE NW SIOUX CENTER, IOWA 51250 | | | |
| WIRING, PICTRL, 8K, UNLDR | | | |
| SIZE | B | DWG. NO. | STI\691814 |

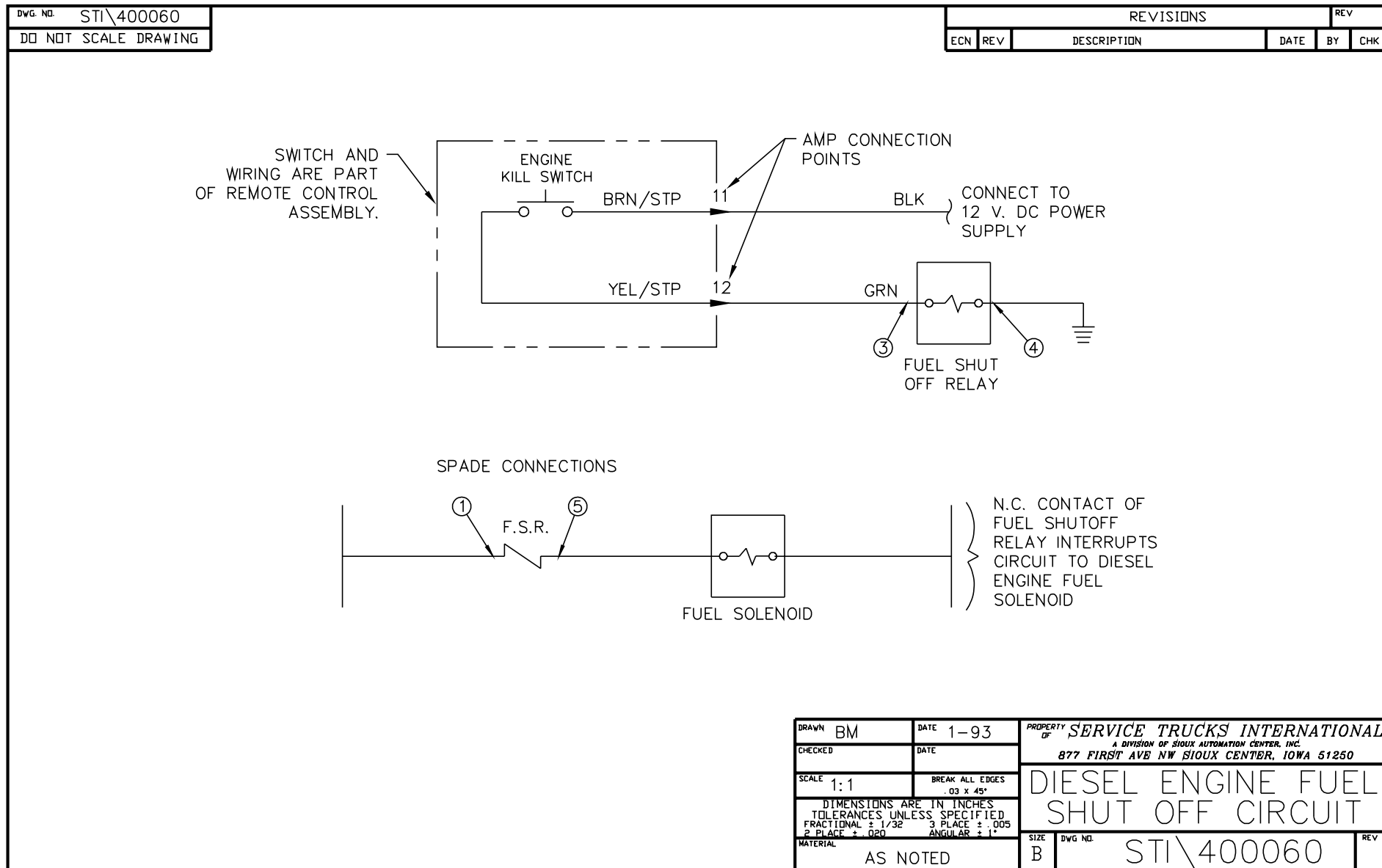



DWG. NO. STI\400066
DO NOT SCALE DRAWING

| REVISIONS | | | | |
|-----------|-----|-------------|------|----|
| ECN | REV | DESCRIPTION | DATE | BY |
| | | | | |

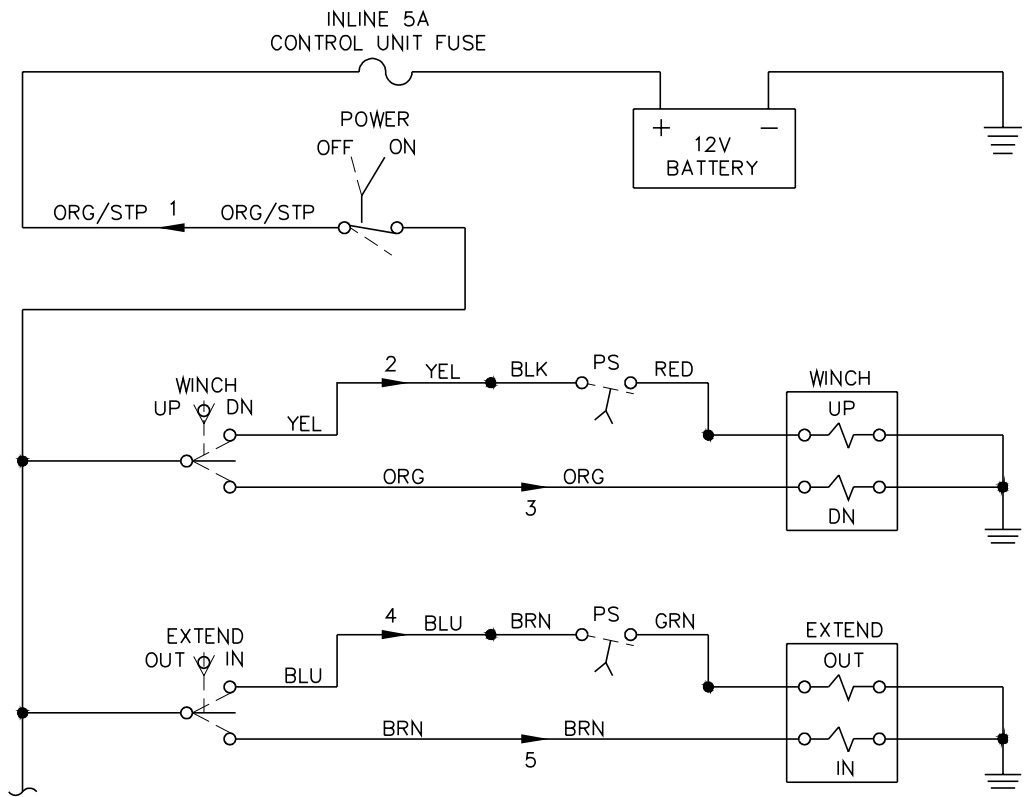

| | | |
|--|---------------------------|---|
| DRAWN RDK | DATE 5-95 | PROPERTY OF SERVICE TRUCKS INTERNATIONAL |
| CHECKED | DATE | A DIVISION OF SIOUX AUTOMATION CENTER, INC. |
| SCALE 1:1 | BREAK ALL EDGES .03 X 45° | 877 FIRST AVE NW SIOUX CENTER, IOWA 51250 |
| DIMENSIONS ARE IN INCHES TOLERANCES UNLESS SPECIFIED FRACTIONAL ± 1/32 3 PLACE ± .005 2 PLACE ± .020 ANGULAR ± 1° | | SCHEMATIC FOR OVERLOAD PROTECTION (POSITIVE SWITCH) |
| MATERIAL AS NOTED | SIZE B | DWG. NO. STI\400066 |



DWG. NO. STI\691812
DO NOT SCALE DRAWING

| REVISIONS | | | | | REV | A |
|-----------|-----|--------------------------|------|-----|-----|---|
| ECN | REV | DESCRIPTION | DATE | BY | CHK | |
| 1635 | A | ADD OPTIONS & LEVEL INFO | 4-02 | CAS | | |

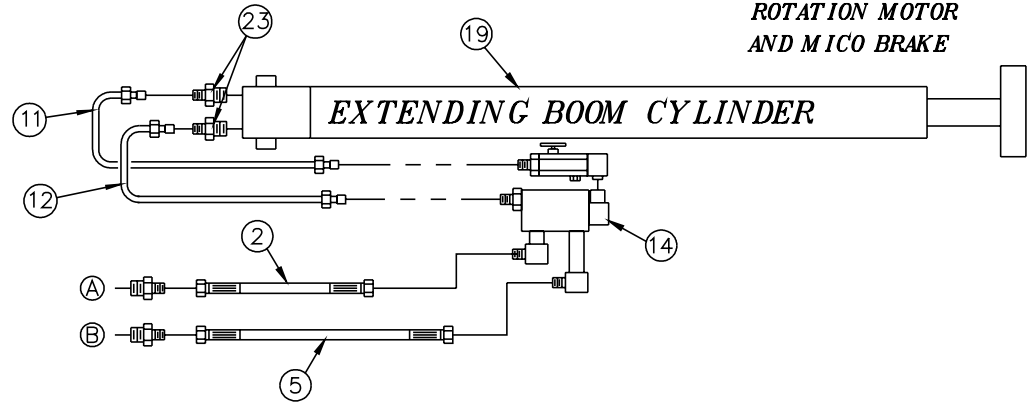
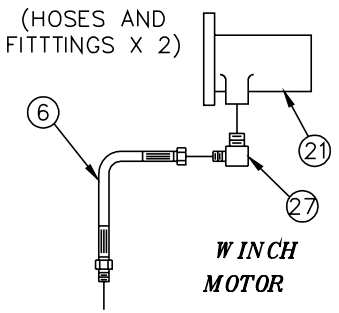
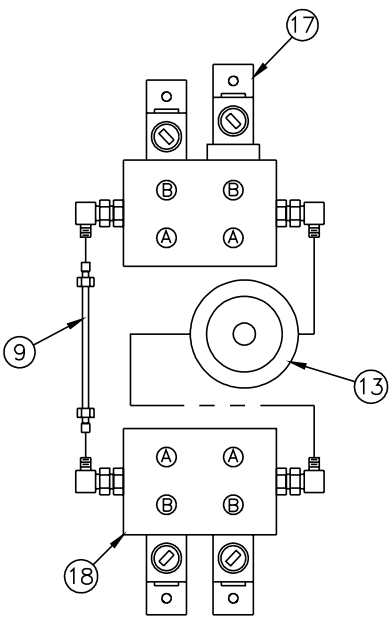
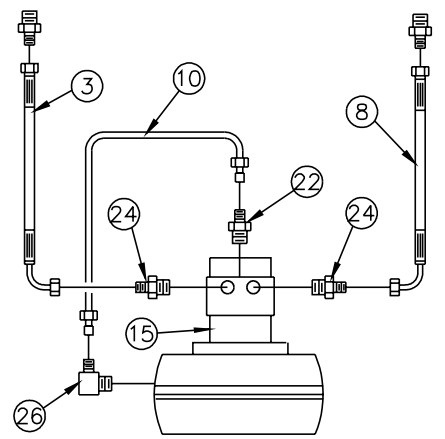
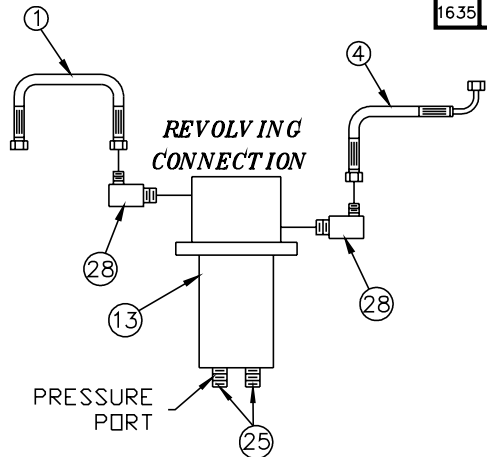
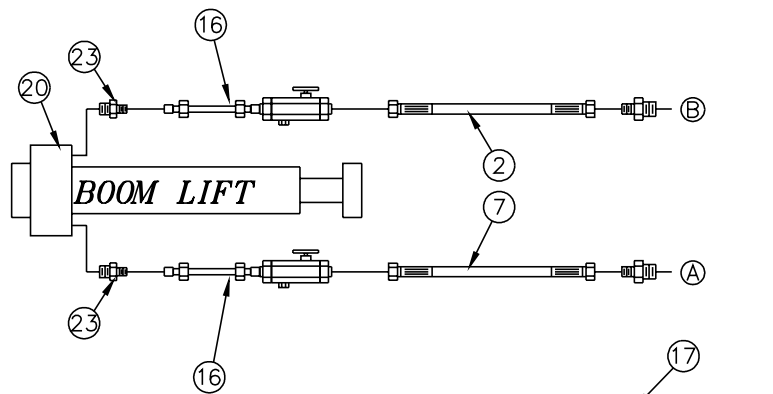

| | | | | | |
|---|-----|------------------------------|------|---|------------|
| DRAWN | MH | DATE | 6-98 | PROPERTY OF SERVICE TRUCKS INTERNATIONAL | |
| CHECKED | | DATE | | A DIVISION OF SIOUX AUTOMATION CENTER, INC. | |
| | | | | 877 FIRST AVE NW SIOUX CENTER, IOWA 51250 | |
| SCALE | 1:1 | BREAK ALL EDGES .03 x 45° | | HYDRAULIC PICTORIAL LAYOUT FOR 8000 CRANE | |
| DIMENSIONS ARE IN INCHES TOLERANCES UNLESS SPECIFIED | | | | | |
| FRACTIONAL ± 1/32 | | 3 PLACE ± .005 | | SIZE | B |
| 2 PLACE ± .020 | | ANGULAR ± 1° | | DWG. NO. | STI\691812 |
| MATERIAL | | | | REV | A |
| AS NOTED | | | | | |

HYDRAULIC PICTORIAL LAYOUT FOR 8000 HYD. CRANE

| OPTION | LVL | ITEM | PART NO. | QTY. | DESCRIPTION |
|--------|-----|------|---------------|------|--------------------------------|
| | L | 1 | ST\670002 | 1 | HOSE,HYD,1/2,16 |
| | L | 2 | ST\670030 | 2 | HOSE,HYD,3/8,22 |
| | L | 3 | ST\670083 | 1 | HOSE,HYD,3/8,16 |
| | L | 4 | ST\670086 | 1 | HOSE,HYD,1/2,9 |
| | L | 5 | ST\670031 | 1 | HOSE,HYD,3/8,23.5 |
| | L | 6 | ST\670088 | 2 | HOSE,HYD,3/8,11 |
| | L | 7 | ST\670089 | 1 | HOSE,HYD,3/8,24 |
| | L | 8 | ST\670090 | 1 | HOSE,HYD,3/8,14 |
| | L | 9 | ST\670091 | 1 | TUBE,HYD,1/2,10 |
| | L | 10 | ST\670092 | 1 | TUBE,HYD,1/4,11 |
| | L | 11 | ST\670036 | 1 | TUBE,HYD,3/8,15.25 |
| | L | 12 | ST\670037 | 1 | TUBE,HYD,3/8,14.38 |
| | L | 13 | ST\680124 | 1 | CONN,ROTATE,8K,10K,ASSY |
| | L | 14 | ST\680138 | 1 | VALVE,CHECK,6K,8K,ASSY |
| | L | 15 | ST\680139 | 1 | ROTATE,8K,ASSY |
| | L | 16 | ST\680140 | 2 | CNTRL,FLOW,CYL,LIFT,ASSY |
| | L | 17 | ST\680141 | 1 | VALVE,2BANK,ASSY,W/REG |
| | L | 18 | ST\680142 | 1 | VALVE,2BANK,ASSY |
| | L | 19 | ST\700020 | 1 | CYL,EXTNSN,8K,6K |
| | L | 20 | ST\700022-1 | 1 | CYL,LIFT,8K |
| | L | 21 | ST\700032 | 1 | MOTOR,WINCHM,HYD,8K |
| | L | 22 | HYD6400-4-4 | 1 | ADPT,CONN,04,MJIC,04,MORG |
| | L | 23 | HYD6400-6-6 | 4 | ADPT,CON,06,MJIC,06,MORG |
| | L | 24 | HYD6400-6-10 | 2 | ADPT,CONN,06,MJIC,10,MORG |
| | L | 25 | HYD6400-L-8-8 | 2 | ADPT,CONN,LONG,08,MJIC,08,MORG |
| | L | 26 | HYD6801-4-4 | 1 | ADPT,ELBOW,04,MJIC,04,MORG,90D |
| | L | 27 | HYD6801-6-10 | 2 | ADPT,ELBOW,06,MJIC,10,MORG,90D |
| | L | 28 | HYD6801-8-8 | 2 | ADPT,ELBOW,08,MJIC,08,MORG,90D |
| TIGER | U | | ST\680069 | 1 | VALVE,UNLDR,10K,8K,ASSY |
| D | U | | ST\680069 | -1 | VALVE,UNLDR,10K,8K,ASSY |
| D | L | | ST\680092 | 1 | VALVE,PROPRTNL,8K,10K,ASSY |
| TIGER | U | NS | HYD304-C-8 | 2 | ADPT,CAP,08,FJIC |
| TIGER | U | NS | ST\700057 | 1 | HEAD,FILTER,3/4"NPTF,ZINGA |
| TIGER | U | NS | ST\700058 | 1 | ELEMENT,FILTER,10MICRON,ZINGA |

| OPTION | OPTION DESCRIPTION |
|--------|-----------------------|
| A | ANTI-TWO BLOCK |
| B | 2 FT EXTENDED BOOM |
| C | 4 FT EXTENDED BOOM |
| D | PROPORTIONAL CONTROLS |
| E | STAINLESS STEEL CABLE |
| F | OVERLOAD PROTECTION |
| | STANDARD EQUIPMENT |

ST\691812-1





DWG. NO. STI\400041
DO NOT SCALE DRAWING

| REVISIONS | | | | | REV |
|-----------|-----|--|------|-----|-----|
| ECN | REV | DESCRIPTION | DATE | BY | CHK |
| | A | STI\700373 WAS STI\700061 STI\700405 WAS STI\700056 | 8-96 | RDK | |

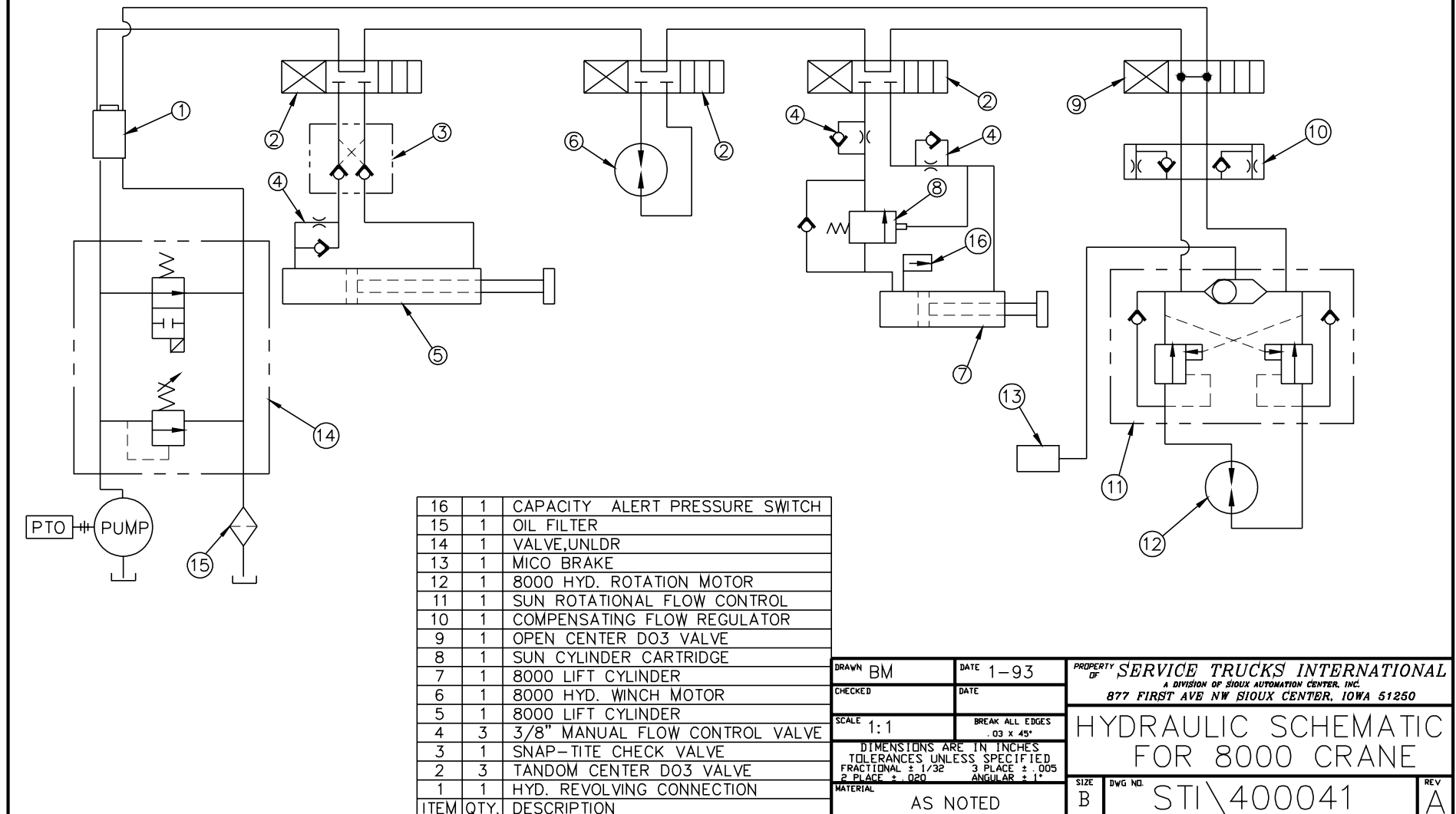

| | | |
|------|------|--------------------------------|
| 16 | 1 | CAPACITY ALERT PRESSURE SWITCH |
| 15 | 1 | OIL FILTER |
| 14 | 1 | VALVE, UNLDR |
| 13 | 1 | MICO BRAKE |
| 12 | 1 | 8000 HYD. ROTATION MOTOR |
| 11 | 1 | SUN ROTATIONAL FLOW CONTROL |
| 10 | 1 | COMPENSATING FLOW REGULATOR |
| 9 | 1 | OPEN CENTER DO3 VALVE |
| 8 | 1 | SUN CYLINDER CARTRIDGE |
| 7 | 1 | 8000 LIFT CYLINDER |
| 6 | 1 | 8000 HYD. WINCH MOTOR |
| 5 | 1 | 8000 LIFT CYLINDER |
| 4 | 3 | 3/8" MANUAL FLOW CONTROL VALVE |
| 3 | 1 | SNAP-TITE CHECK VALVE |
| 2 | 3 | TANDOM CENTER DO3 VALVE |
| 1 | 1 | HYD. REVOLVING CONNECTION |
| ITEM | QTY. | DESCRIPTION |

| | | | |
|---|----------|-----------------|-----------|
| DRAWN | BM | DATE | 1-93 |
| CHECKED | | DATE | |
| SCALE | 1:1 | BREAK ALL EDGES | .03 x 45° |
| DIMENSIONS ARE IN INCHES TOLERANCES UNLESS SPECIFIED | | | |
| FRACTIONAL ± 1/32 | | 3 PLACE ± .005 | |
| 2 PLACE ± .020 | | ANGULAR ± 1° | |
| MATERIAL | AS NOTED | | |

| | | | |
|---------------------------------------|---|---|------------|
| PROPERTY OF | | SERVICE TRUCKS INTERNATIONAL | |
| | | A DIVISION OF SIOUX AUTOMATION CENTER, INC. | |
| | | 877 FIRST AVE NW SIOUX CENTER, IOWA 51250 | |
| HYDRAULIC SCHEMATIC FOR 8000 CRANE | | | |
| SIZE | B | DWG. NO. | STI\400041 |
| | | REV | A |



DWG. NO. STI\680139
DO NOT SCALE DRAWING

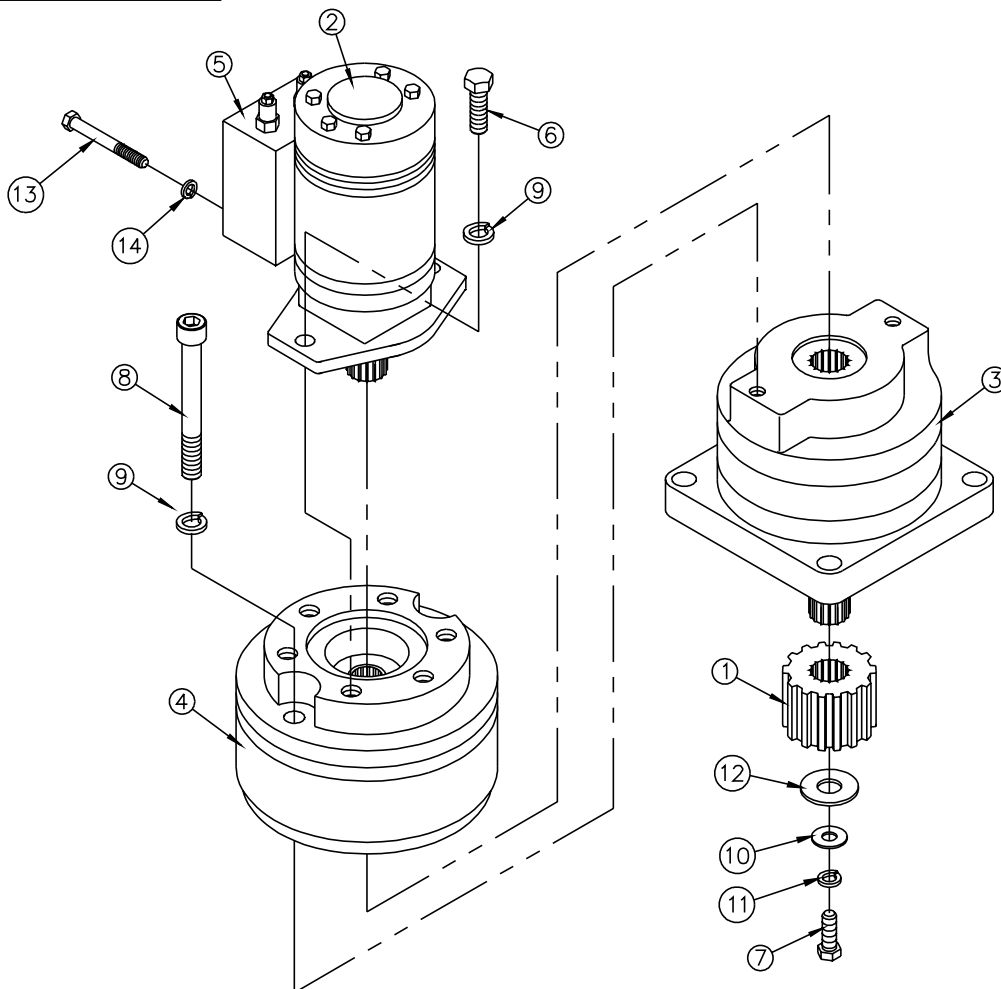

| REVISIONS | | | | | REV |
|-----------|-----|--|-------|----|-----|
| ECN | REV | DESCRIPTION | DATE | BY | CHK |
| | A | P/N WAS STI\400073 | 10-99 | MH | |
| | B | SPDHB12X4NC WAS SPDHB12X412NC STI700465 WAS STI700045 | 11-99 | HW | |

**WARNING!**

HYDRAULIC OIL PRESSURE CAN
PUNCTURE OR CUT SKIN, RESULTING
IN SERIOUS INJURY OR DEATH.

NOTE:

- OIL TO BE ADDED TO THE TORQUE HUB.

| | | | |
|------|--------------|------|--------------------------|
| | OIL85W140 | 1 | OIL,85W140 (1/2 PINT) |
| 14 | WSH516LOCK | 4 | WSH,LOCK,5/16 |
| 13 | BLT516X212NC | 4 | BLT,HEX,5/16,2-1/2,NC,G5 |
| 12 | WSH58FLAT | 1 | WSH,FLAT,5/8 |
| 11 | WSH38LOCK | 1 | WSH,LOCK,3/8 |
| 10 | WSH38FLAT | 1 | WSH,FLAT,3/8 |
| 9 | WSH12LOCK | 4 | WSH,LOCK,1/2 |
| 8 | SPDHB12X4NC | 2 | BLT,SHCS,1/2,4,NC |
| 7 | BLT38X1NC | 1 | BLT,HEX,3/8,1,NC,G5 |
| 6 | BLT12X114NC | 2 | BLT,HEX,1/2,1-1/4,NC,G5 |
| 5 | STI700059 | 1 | CNTRL,MOTOR,ROTATE,SUN |
| 4 | STI700465 | 1 | BRAKE,MICO,2PC |
| 3 | STI700044 | 1 | HUB,TORQUE |
| 2 | STI700034 | 1 | MOTOR,ROTATE,HYD,8K |
| 1 | STIP010013 | 1 | GEAR,ROTATE,PINION,8K |
| ITEM | PART NO. | QTY. | DESCRIPTION |

| | | | | |
|--|----------|-----------------|-----------|--|
| DRAWN | MH | DATE | 10-99 | PROPERTY OF SERVICE TRUCKS INTERNATIONAL A DIVISION OF SIOUX AUTOMATION CENTER, INC. 877 FIRST AVE NW SIOUX CENTER, IOWA 51250 |
| CHECKED | | DATE | | |
| SCALE | 1:4 | BREAK ALL EDGES | .03 x 45° | ROTATE,8K,ASSY |
| DIMENSIONS ARE IN INCHES TOLERANCES UNLESS SPECIFIED FRACTIONAL ± 1/32 3 PLACE ± .005 2 PLACE ± .020 ANGULAR ± 1° | | | | |
| MATERIAL | AS NOTED | | SIZE | |
| | | | DWG. NO. | STI\680139 |
| | | | REV | B |

DWG NO. STI600061
DO NOT SCALE DRAWING

| REVISIONS | | | | | REV |
|-----------|------|-------------|------|----|-----|
| ECN | REV. | DESCRIPTION | DATE | BY | CHK |

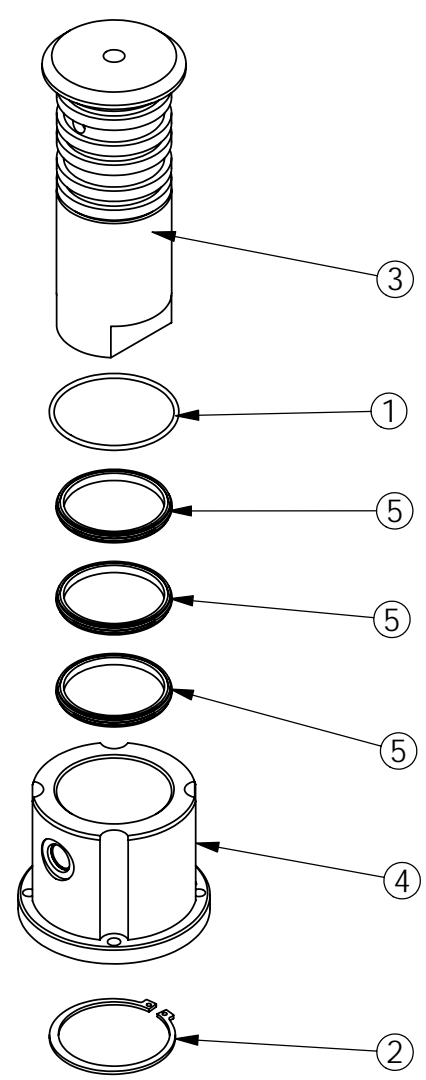
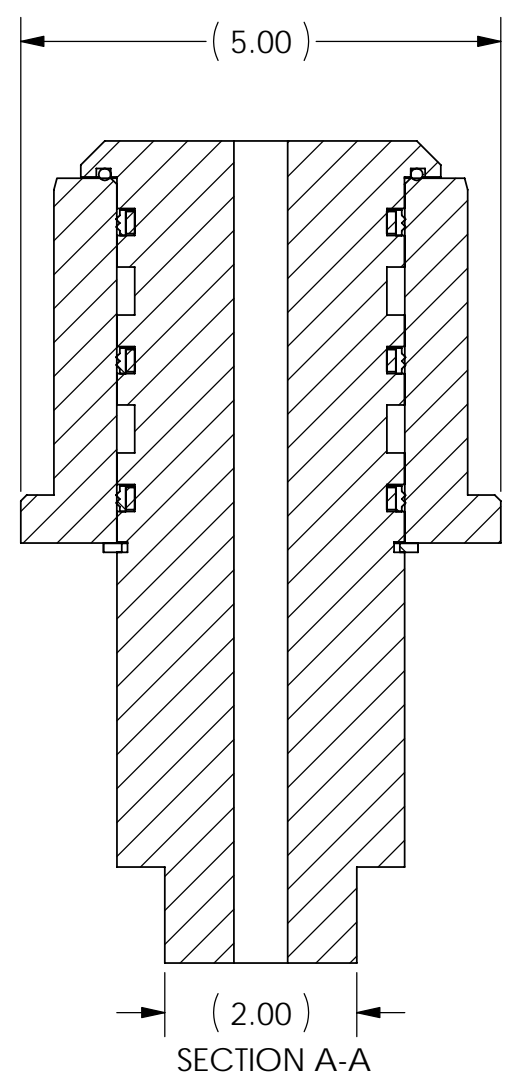
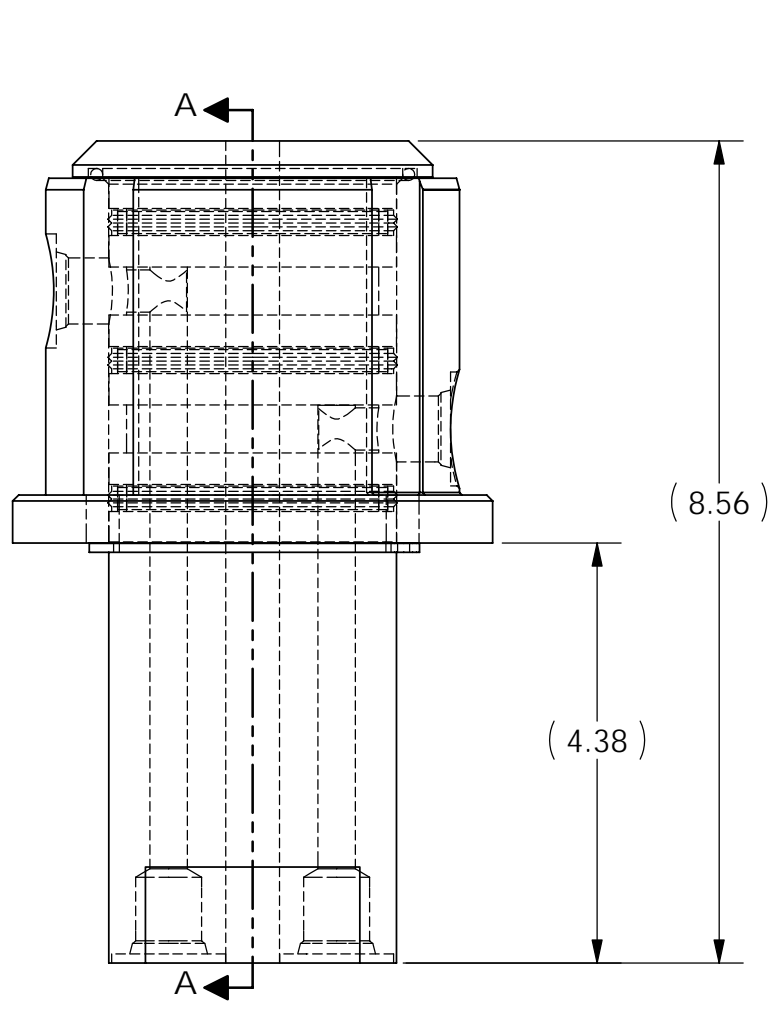

| ITEM # | QTY. | PART # | DESCRIPTION |
|--------|------|-----------|------------------------|
| 1 | 1 | SPORG113 | ORG,3.125,3.38,#113 |
| 2 | 1 | SPOSRG3 | RING,SNAP,OUTSIDE,3 |
| 3 | 1 | STI610560 | CONN,ROTATE,HYD,8K,10K |
| 4 | 1 | STI610561 | SLEEVE,CONN,HYD,8K,10K |
| 5 | 3 | STI700048 | SEAL,PARKER,334 |

DRAWN SZ DATE 4-06
 CHECKED DATE
 SCALE 1:2 BREAK ALL EDGES .03 X 45°
 DIMENSIONS ARE IN INCHES
 TOLERANCES UNLESS SPECIFIED
 FRACTIONAL ± 1/32 3 PLACE ± .005
 2 PLACE ± .020 ANGULAR ± 1°
 MATERIAL AS NOTED

PROPERTY OF: SERVICE TRUCKS INTERNATIONAL
 A DIVISION OF SIOUX AUTOMATION CENTER INC.
 877 FIRST AVE NW SIOUX CENTER, IA 51250

CONN,ROTATE,HYD,8K,10K,ASSY

SIZE B DWG NO. STI600061 REV -
 SHEET 1 OF 1



DWG. NO. STI\680084
DO NOT SCALE DRAWING

| REVISIONS | | | | | REV | D |
|-----------|-----|---------------------------|-------|-----|-----|---|
| ECN | REV | DESCRIPTION | DATE | BY | CHK | |
| | A | STI700567 WAS STI700484 | 12-99 | MH | | |
| | B | STI\570032 LENGHT WAS 17 | 12-99 | BJL | | |
| | C | UPDATED PRINTS | 1-00 | NS | | |
| 1580 | D | STI\570034 WAS STI\570032 | 3-02 | BPL | | |

NOTE:
1.) SEE HYD. PICTORAL PRINT FOR PROPER INSTALLATION INSTRUCTIONS.

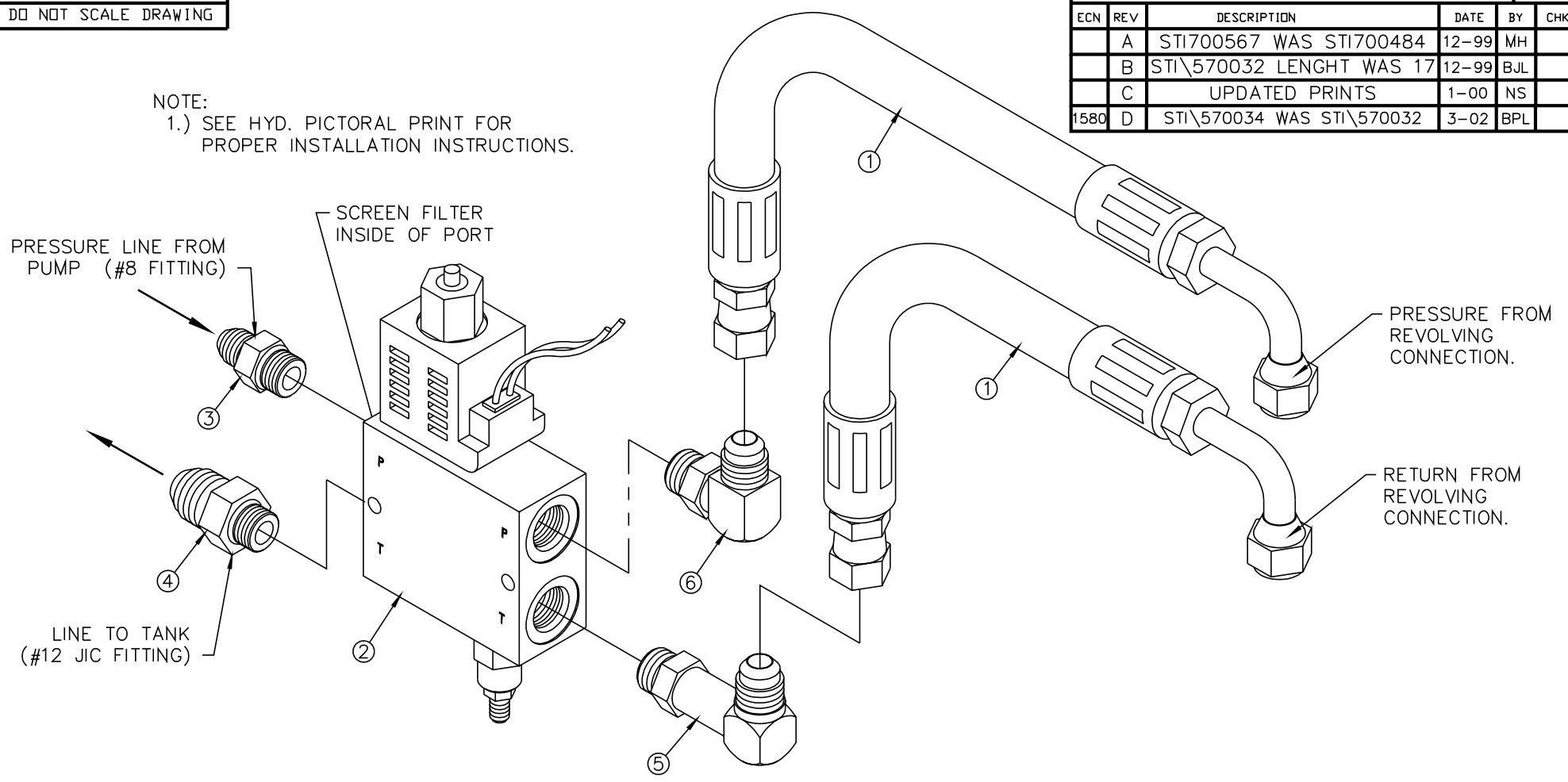

| | | | |
|------|----------------|------|--------------------------------|
| 6 | HYD6801-8-10 | 1 | ADPT,ELBOW,08,MJIC,10,MORG,90D |
| 5 | HYD6801LL-8-10 | 1 | ADPT,ELBOW,LL,08,MJIC,10,MORG |
| 4 | HYD6400-12-10 | 1 | ADPT,CONN,12,MJIC,10,MORG |
| 3 | HYD6400-8-10 | 1 | ADPT,CONN,08,MJIC,10,MORG |
| 2 | STI\700567 | 1 | VALVE,UNLOADER,RELIEF,100RG |
| 1 | STI\570034 | 2 | HOSE,HYD,1/2,22,08FJ,08FJ90 |
| ITEM | PART NO. | QTY. | DESCRIPTION |

| | | | |
|--|----------|-----------------|-----------|
| DRAWN | BM | DATE | 3-98 |
| CHECKED | | DATE | |
| SCALE | 1:2 | BREAK ALL EDGES | .03 x 45° |
| DIMENSIONS ARE IN INCHES TOLERANCES UNLESS SPECIFIED FRACTIONAL ± 1/32 3 PLACE ± .005 2 PLACE ± .020 ANGULAR ± 1° | | | |
| MATERIAL | AS NOTED | | |

| | | | |
|--------------------------------|---|-----|--|
| PROPERTY OF | SERVICE TRUCKS INTERNATIONAL A DIVISION OF SIOUX AUTOMATION CENTER, INC. 877 FIRST AVE NW SIOUX CENTER, IOWA 51250 | | |
| VALVE, UNLDR, 8K, 10K, ASSY | | | |
| SIZE | DWG. NO. | REV | |
| B | STI\680084 | D | |



DWG. NO. STI\690008
DO NOT SCALE DRAWING

| REVISIONS | | | | |
|-----------|-----|-------------|------|-----|
| ECN | REV | DESCRIPTION | DATE | CHK |

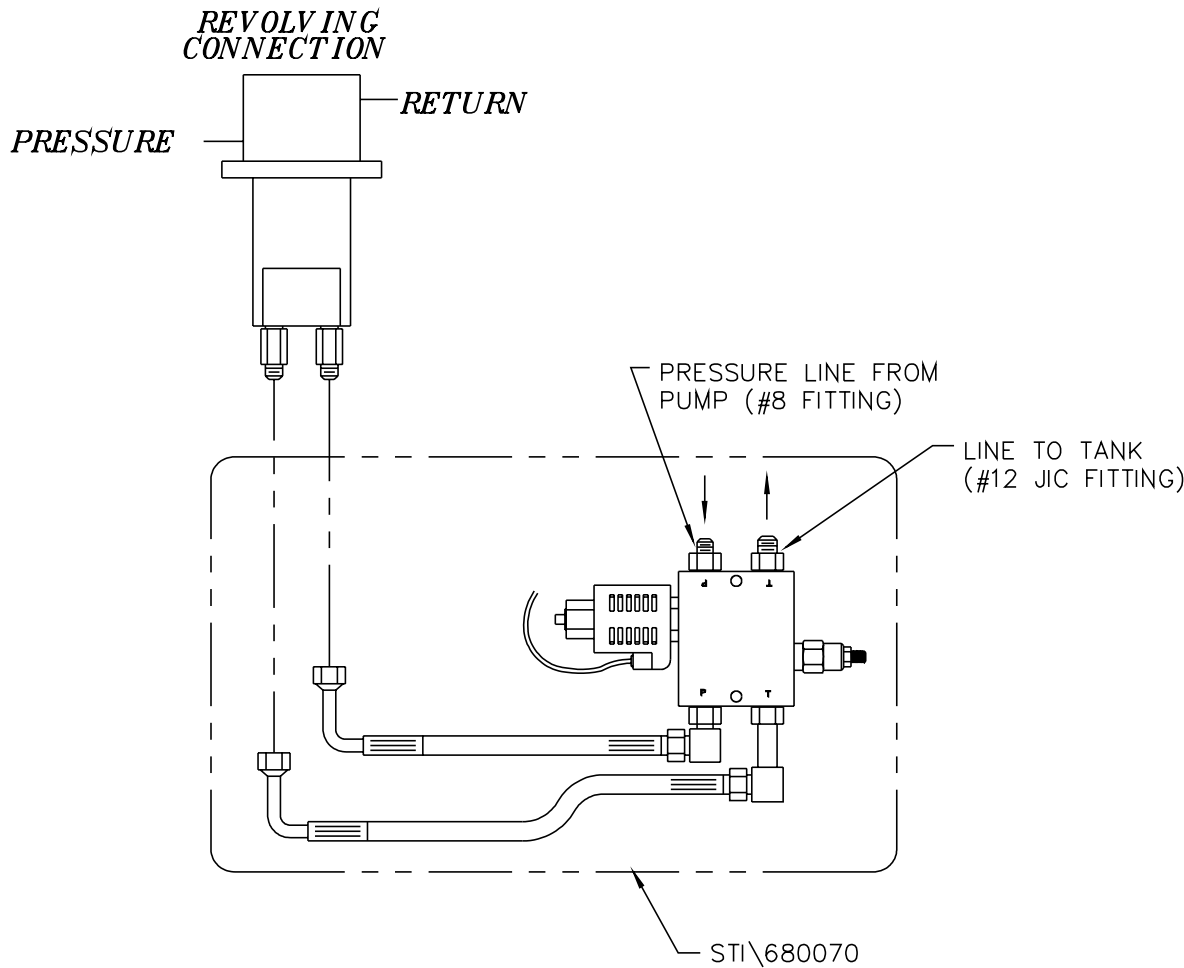

WARNING!
HYDRAULIC OIL PRESSURE CAN PUNCTURE OR CUT SKIN, RESULTING IN SERIOUS INJURY OR DEATH.

ALWAYS RELEASE HYDRAULIC OIL PRESSURE BY (1) RETURNING ALL COMPONENTS TO TRAVELING POSITION AND (2) TURNING OFF IGNITION AND REMOVING KEY.

| | | |
|---|---------------------------|---|
| DRAWN BM | DATE 4-98 | PROPERTY OF SERVICE TRUCKS INTERNATIONAL |
| CHECKED | DATE | A DIVISION OF SIOUX AUTOMATION CENTER, INC. |
| SCALE 1:1 | BREAK ALL EDGES .03 x 45° | 877 FIRST AVE NW SIOUX CENTER, IOWA 51250 |
| DIMENSIONS ARE IN INCHES TOLERANCES UNLESS SPECIFIED | | 2452 BODY UNLOADER VALVE INSTALLATION |
| FRACTIONAL ± 1/32 3 PLACE ± .005 2 PLACE ± .020 ANGULAR ± 1° | | |
| MATERIAL AS NOTED | SIZE B | DWG NO. STI\690008 |



DWG. NO. STI\680069
DO NOT SCALE DRAWING

| REVISIONS | | | | | REV |
|-----------|-----|-------------------------|-------|----|-----|
| ECN | REV | DESCRIPTION | DATE | BY | CHK |
| | A | STI700567 WAS STI700484 | 12-99 | MH | |
| | B | UPDATED PRINTS | 1-00 | NS | |

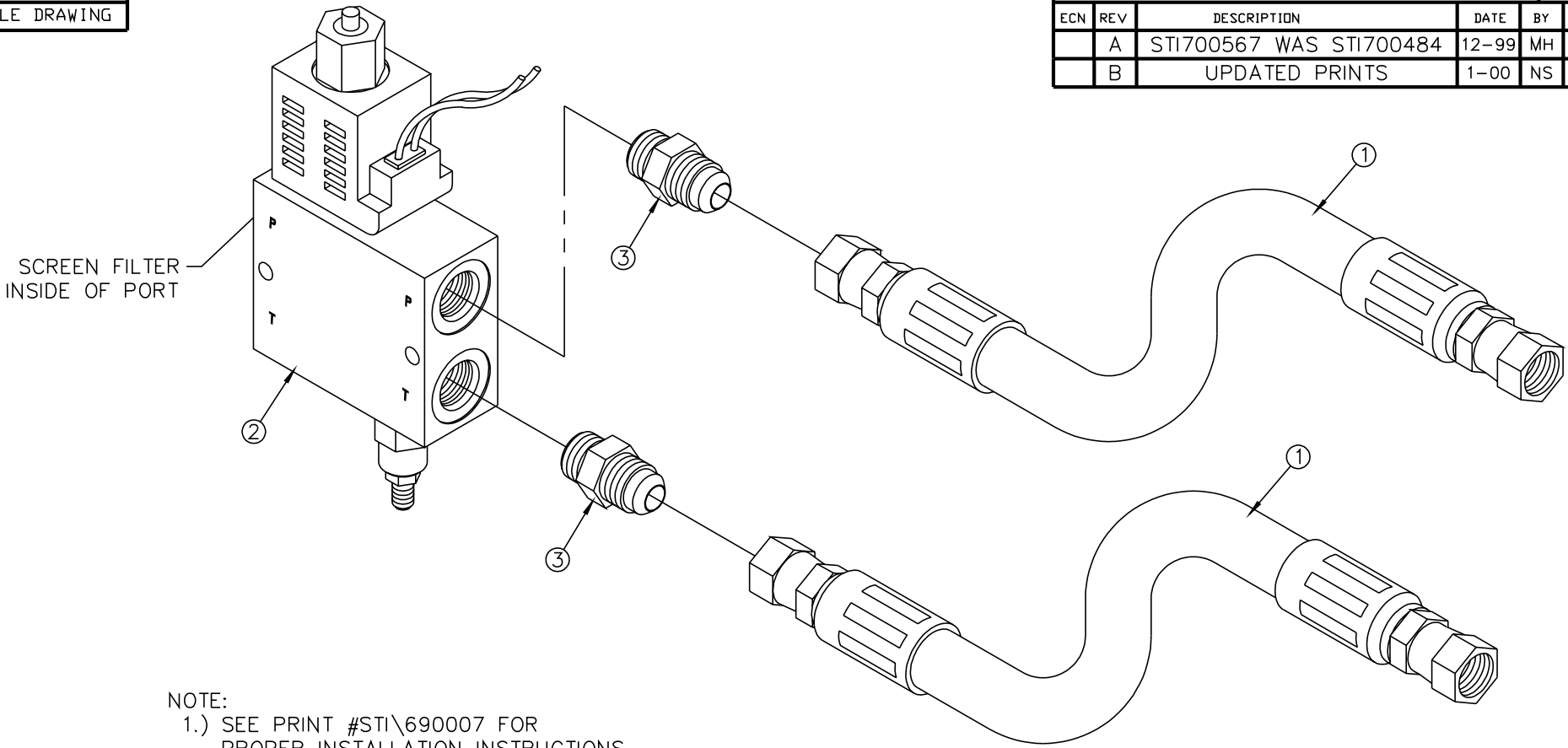

| ITEM | PART NO. | QTY. | DESCRIPTION |
|------|--------------|------|-----------------------------|
| 3 | HYD6400-8-10 | 2 | ADPT,CONN,08,MJIC,10,MORG |
| 2 | STI\700567 | 1 | VALVE,UNLOADER,RELIEF,10ORG |
| 1 | STI\570030 | 2 | HOSE,HYD,1/2,24 |

| | | | | | |
|--|----------|-----------------|-----------|--|---|
| DRAWN | BM | DATE | 4-98 | PROPERTY OF SERVICE TRUCKS INTERNATIONAL A DIVISION OF SIOUX AUTOMATION CENTER, INC. 877 FIRST AVE NW SIOUX CENTER, IOWA 51250 | |
| CHECKED | | DATE | | | |
| SCALE | 1:2 | BREAK ALL EDGES | .03 x 45° | VALVE,UNLDR,10K,8K,ASSY | |
| DIMENSIONS ARE IN INCHES TOLERANCES UNLESS SPECIFIED FRACTIONAL ± 1/32 3 PLACE ± .005 2 PLACE ± .020 ANGULAR ± 1° | | | | | |
| MATERIAL | AS NOTED | | | SIZE | B |
| | DWG. NO. | STI\680069 | | REV | B |



DWG. NO. STI\690007
DO NOT SCALE DRAWING

| REVISIONS | | | | |
|-----------|-----|-------------|------|-----|
| ECN | REV | DESCRIPTION | DATE | CHK |

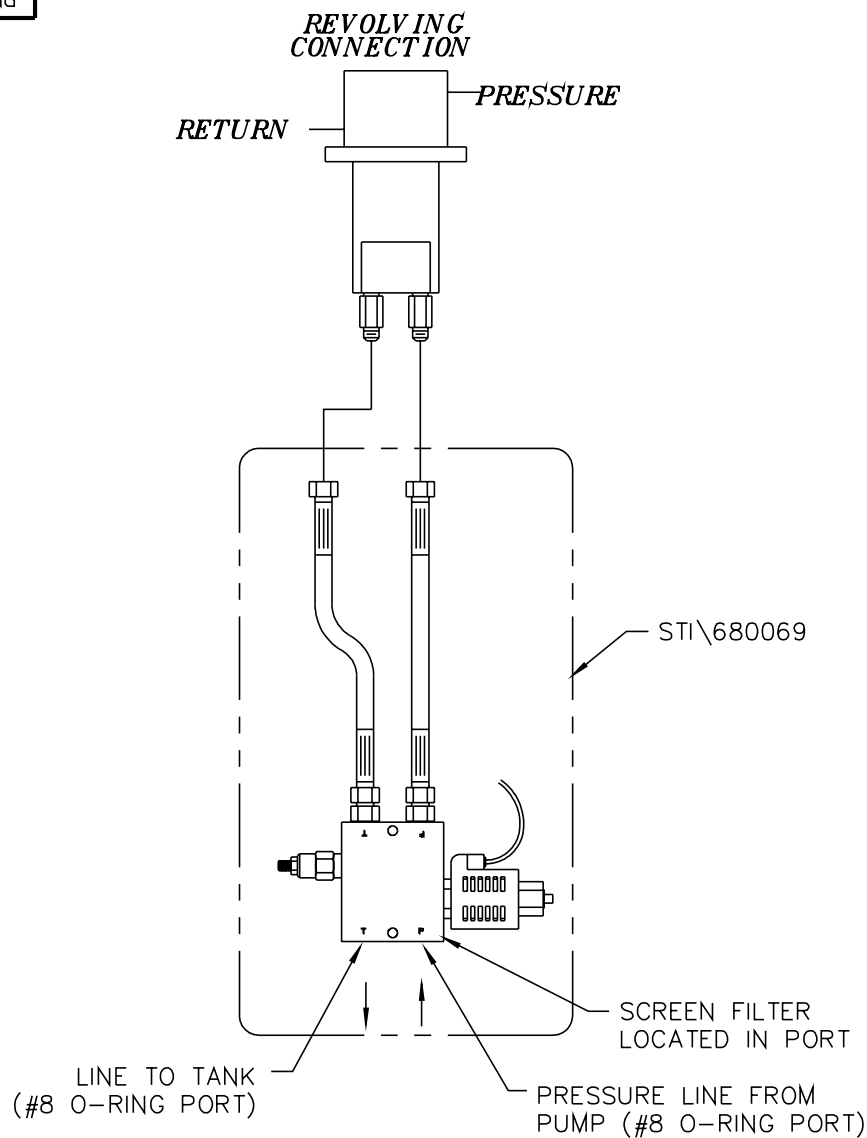

WARNING!

HYDRAULIC OIL PRESSURE CAN PUNCTURE OR CUT SKIN, RESULTING IN SERIOUS INJURY OR DEATH.



ALWAYS RELEASE HYDRAULIC OIL PRESSURE BY (1) RETURNING ALL COMPONENTS TO TRAVELING POSITION AND (2) TURNING OFF IGNITION AND REMOVING KEY.

| | | | |
|--|----------|-----------------|-----------|
| DRAWN | BM | DATE | 4-98 |
| CHECKED | | DATE | |
| SCALE | 1:1 | BREAK ALL EDGES | .03 x 45° |
| DIMENSIONS ARE IN INCHES TOLERANCES UNLESS SPECIFIED FRACTIONAL ± 1/32 3 PLACE ± .005 2 PLACE ± .020 ANGULAR ± 1° | | | |
| MATERIAL | AS NOTED | | |

| | | | |
|--|---|----------|------------|
| PROPERTY OF | SERVICE TRUCKS INTERNATIONAL A DIVISION OF SIOUX AUTOMATION CENTER, INC. 877 FIRST AVE NW SIOUX CENTER, IOWA 51250 | | |
| 10K 8K UNLOADER VALVE CRANE ONLY INSTALLATION | | | |
| SIZE | B | DWG. NO. | STI\690007 |



DWG. NO. STI\700028
DO NOT SCALE DRAWING

| REVISIONS | | | | REV | |
|-----------|-----|-------------|------|-----|-----|
| ECN | REV | DESCRIPTION | DATE | BY | CHK |
| | | | | | |

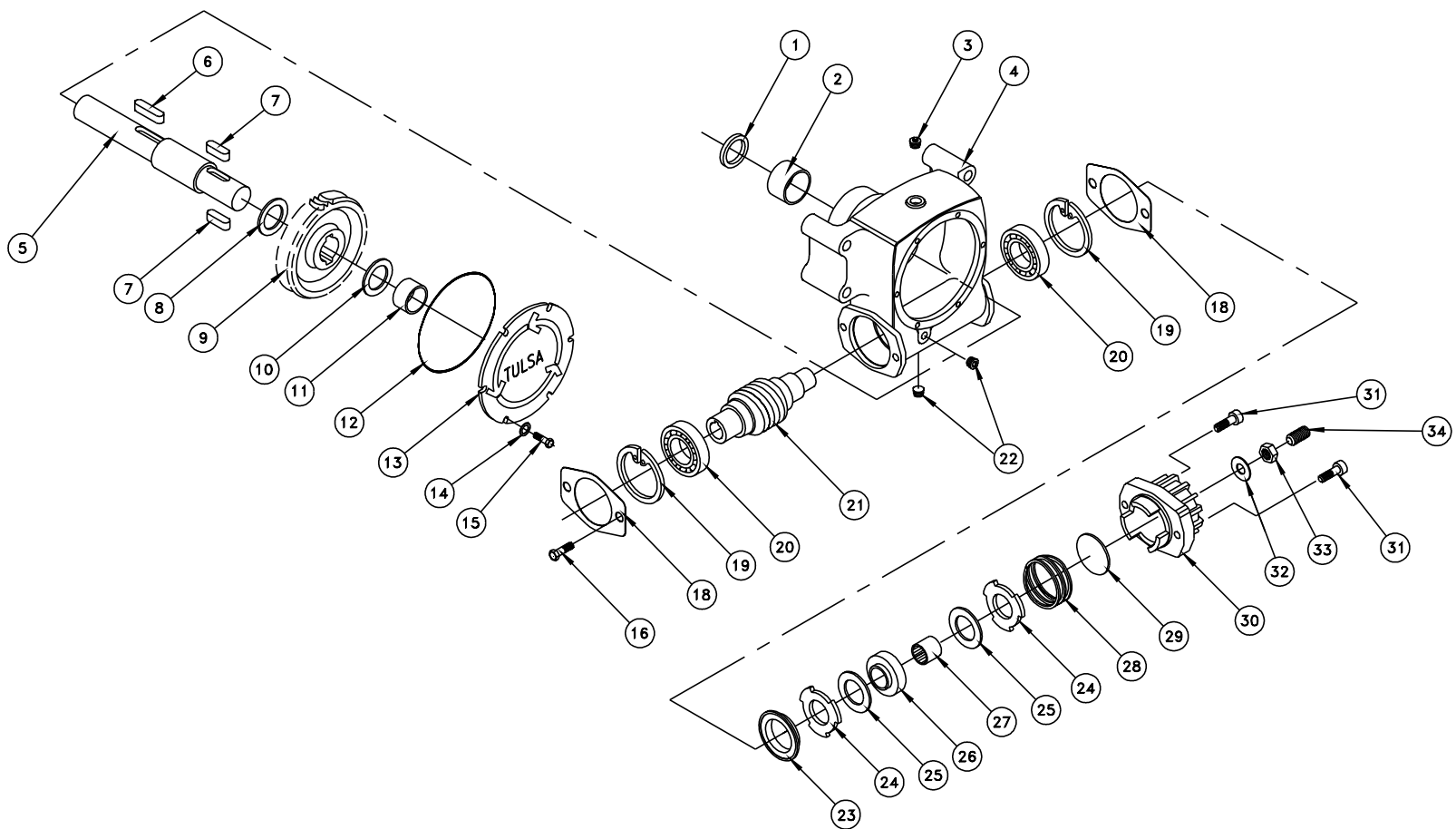

| | | | | | |
|---|----------|------------------------------|------|---|-------------------------------------|
| DRAWN | BM | DATE | 4-93 | PROPERTY OF | SERVICE TRUCKS INTERNATIONAL |
| CHECKED | | DATE | | A DIVISION OF SIOUX AUTOMATION CENTER, INC. | |
| SCALE | 1:8 | BREAK ALL EDGES .03 X 45° | | 877 FIRST AVE NW SIOUX CENTER, IOWA 51250 | |
| DIMENSIONS ARE IN INCHES TOLERANCES UNLESS SPECIFIED | | | | WINCH, CABLE, 6K, 8K | |
| FRACTIONAL ± 1/32 | | 3 PLACE ± .005 | | | |
| 2 PLACE ± .020 | | ANGULAR ± 1° | | | |
| MATERIAL | AS NOTED | | | SIZE | B |
| | | | | DWG. NO. | STI\700028 |
| | | | | REV | |

**REFERENCE PARTS LIST FOR TULSA WINCH HFG938 L-041(80531)**

| <u>ITEM</u> | <u>PART #</u> | <u>DESCRIPTION</u> | <u>QUANTITY</u> |
|-------------|---------------|--------------------|-----------------|
| 1 | 40643 | OIL SEAL | 1 PC |
| 2 | 41314 | BEARING | 1 PC |
| 3 | 4101 | BREATHER KIT | 1 PC |
| 4 | 40640 | HOUSING | 1 PC |
| 5 | 41006 | SHAFT | 1 PC |
| 6 | 41005 | KEY | 1 PC |
| 7 | 40518 | KEY | 2 PC |
| 8 | 40644 | WASHER | 1 PC |
| 9 | 40618 | GEAR | 1 PC |
| 10 | 29017 | WASHER | 1 PC |
| 11 | 40968 | BUSHING | 1 PC |
| 12 | 40547 | O-RING | 1 PC |
| 13 | 40893 | COVER | 1 PC |
| 14 | 40918 | WASHER | 6 PC |
| 15 | 40407 | CAPSCREW | 6 PC |
| 16 | 40410 | CAPSCREW | 2 PC |
| 17 | 33561 | PROTECTOR | 1 PC |
| 18 | 40147 | GASKET | 2 PC |
| 19 | 40396 | RETAINING RING | 2 PC |
| 20 | 40395 | BEARING | 2 PC |
| 21 | 40598 | WORM | 1 PC |
| 22 | 32220 | PIPE PLUG | 2 PC |
| 23 | 40599 | SPACER | 1 PC |
| 24 | 40076 | STATOR PLATE | 2 PC |
| 25 | 40075 | FRICITION DISK | 2 PC |
| 26 | 40617 | HUB | 1 PC |
| 27 | 40113 | CAM CLUTCH | 1 PC |
| 28 | 40077 | SPRING | 1 PC |
| 29 | 40078 | WASHER | 1 PC |
| 30 | 40069 | HOUSING | 1 PC |
| 31 | 40546 | CAPSCREW | 2 PC |
| 32 | 29044 | SEAL WASHER | 1 PC |
| 33 | 40774 | LOCK NUT | 1 PC |
| 34 | 40775 | SET SCREW | 1 PC |



MULTIPLE DISC BRAKE

(dry design - SAE B size)

SERVICE INSTRUCTIONS



NOTE:

This service sheet covers models:

| | |
|------------|------------|
| 02-556-306 | 02-556-340 |
| 02-556-308 | 02-556-346 |
| 02-556-310 | 02-556-358 |
| 02-556-312 | 02-556-360 |
| 02-556-314 | 02-556-364 |
| 02-556-316 | 02-556-366 |
| 02-556-318 | 02-556-368 |
| 02-556-320 | 02-556-372 |
| 02-556-322 | 02-556-376 |
| 02-556-324 | 02-556-378 |
| 02-556-326 | 02-556-380 |
| 02-556-328 | 02-556-382 |
| 02-556-330 | 02-556-384 |
| 02-556-332 | 02-556-386 |
| 02-556-334 | 02-556-392 |
| 02-556-336 | |

NOTE

All repair kits include mounting face gaskets and o-rings. Some motors and gearboxes allow for the use of o-rings to seal the mounting faces on either side of the brake.

Do not use the o-ring and face gasket together to seal a mounting face.

REPAIR KITS

(Refer to Figure 1 for item numbers)

| NUMBER | DESCRIPTION | INCLUDES |
|------------|--|--|
| 12-501-377 | Lining Kit for 02-556-372 | Case Seal (3) Stator Discs (10) Rotor Discs (11) Plate (12) |
| 20-060-100 | Lining Kit | Case Seal (3) Stator Discs (10) Rotor Discs (11) Plate (12) |
| 20-060-102 | Lining Kit for 02-556-316 | Case Seal (3) Stator Discs (10) Rotor Discs (11) Plate (12) |
| 20-060-105 | Lining Kit for 02-556-310 02-556-312 02-556-346 02-556-368 | Case Seal (3) Stator Discs (10) Rotor Discs (11) Plate (12) |
| 20-060-107 | Lining Kit for 02-556-376 02-556-392 | Case Seal (3) Stator Discs (10) Rotor Discs (11) Plate (12) |
| 20-060-109 | Lining Kit for 02-556-358 02-556-380 02-556-382 02-556-384 02-556-386 | Case Seal (3) Stator Discs (10) Rotor Discs (11) Plate (12) |
| 02-500-142 | Bearing Kit | Case Seal (3) Oil Seal (20) Bearing (16) Retaining ring (15) Retaining ring (19) |
| 02-500-168 | Bearing Kit for 02-556-340 02-556-364 02-556-392 | Case Seal (3) Oil Seal (20) Bearing (16) Retaining ring (15) Retaining ring (19) |
| 02-500-210 | Bearing Kit for 02-556-310 02-556-312 02-556-316 | Case Seal (3) Oil Seal (20) Bearing (16) Retaining ring (15) Retaining ring (19) |
| 02-500-141 | O-ring Kit | Case Seal (3) Back-up Rings (5 & 8) O-rings (4 & 7) Oil Seal (20) |
| 02-500-167 | O-ring Kit for 02-556-340 02-556-364 02-556-392 | Case Seal (3) Back-up rings (5 & 8) O-rings (4 & 7) Oil Seal (20) |
| 02-500-207 | O-ring Kit for 02-556-310 02-556-312 02-556-316 | Case Seal (3) Back-up rings (5 & 8) O-rings (4 & 7) Oil Seal (20) |

**NOTE**

This literature services various models in this brake series. The components shown in Figures 1-6 may appear different than what is found in your brake. See cover page for items included in kits.

DISASSEMBLY

(Refer to Figures 1 thru 6)

1. Remove pressure plate (2) from cover (18) by removing washer head cap screws (1).

▲ CAUTION

Pressure plate is under spring tension of approximately 907 kgf (2000 lb). The four washer head cap screws should be loosened evenly to relieve this force. If a hydraulic press is available, 1361 kgf (3000 lb) minimum, the pressure plate can be held in position while removing the washer head cap screws.

2. Remove case seal (3) from cover (18).
3. Remove piston (6) from pressure plate (2).
4. Remove o-ring (4), back-up ring (5), o-ring (7) and back-up ring (8) from piston (6).
5. Remove stack assembly, consisting of discs (10), plate (12) and friction discs (11) from cover (18). Record the stacking arrangement for reassembly purposes.
6. **NOTE: Not all models use the same number of springs or spring pattern. Record this information for assembly purposes.** Remove dowel pins (17), springs (13) and spring retainer (14) from cover (18).
7. Remove retaining ring (15) from cover (18).
8. Remove shaft by pressing or using a soft mallet on male end of shaft (9).
9. Remove retaining ring (19) and bearing (16) from shaft (9).
10. Press rotary oil seal (20) from cover (18).

ASSEMBLY

(Refer to Figures 1 thru 6)

LUBRICATE ALL RUBBER COMPONENTS FROM REPAIR KIT WITH CLEAN TYPE FLUID USED IN THE SYSTEM.

1. Clean all parts thoroughly before assembly.
2. Press new rotary oil seal (20) into cover (18). Note direction of seal.
3. Install new bearing (16) and retaining ring (19) on shaft (9).
4. Insert shaft assembly and retaining ring (15) in cover (18).
5. Insert dowel pins (17), spring retainer (14) and springs (13) in cover (18). **NOTE: Be sure to use the same number of springs and spring pattern as recorded during disassembly.**
6. Position plate (12) on to springs (13). **NOTE: Discs (10 & 11) and plate (12) should remain dry during installation. No oil residue should be allowed to contaminate disc surfaces.**
7. Place a new friction disc (11) on shaft (9) until it contacts plate (12).
8. Add additional new discs (10) and new friction discs (11) as required to complete assembly. **NOTE: Some models are stacked differently. Check to see if the stacking arrangement for your model is listed in Figures 2 thru 5.**
9. Install new o-ring (4), new back-up ring (5), new o-ring (7) and new back-up ring (8) on piston (6). Note order of o-rings and back-up rings. Insert piston (6) into pressure plate (2). Be careful not to shear o-rings or back-up rings.
10. Install new case seal (3) in cover (18).
11. Position pressure plate (2) on cover (18) aligning dowel pins (17) with holes in pressure plate.
12. Install washer head cap screws (1) and tighten evenly to draw pressure plate (2) to cover (18). Torque washer head cap screws 74.6 N-m (55 lb-ft). **NOTE: A hydraulic press will simplify installation of pressure plate on cover. Clamp pressure plate in position while tightening the washer head cap screws.**

▲ CAUTION

If hydrostatic bench testing is performed on the brake assembly, release pressure should not exceed 137.9 bar (2000 psi) unless two additional bolts are used for supplemental clamping.

SPRING CHART

| Model | Red Springs (13) | Blue Springs (13) | Model | Red Springs (13) | Blue Springs (13) |
|------------|------------------|-------------------|------------|------------------|-------------------|
| 02-556-306 | 6 | 3 | 02-556-340 | 12 | 0 |
| 02-556-308 | 6 | 3 | 02-556-346 | 8 | 0 |
| 02-556-310 | 8 | 0 | 02-556-358 | 9 | 0 |
| 02-556-312 | 9 | 0 | 02-556-360 | 8 | 0 |
| 02-556-314 | 8 | 4 | 02-556-364 | 10 | 2 |
| 02-556-316 | 4 | 4 | 02-556-366 | 4 | 0 |
| 02-556-318 | 4 | 2 | 02-556-368 | 8 | 0 |
| 02-556-320 | 10 | 0 | 02-556-372 | 4 | 0 |
| 02-556-322 | 6 | 2 | 02-556-376 | 9 | 0 |
| 02-556-324 | 8 | 4 | 02-556-378 | 8 | 4 |
| 02-556-326 | 6 | 3 | 02-556-380 | 4 | 4 |
| 02-556-328 | 6 | 3 | 02-556-382 | 4 | 6 |
| 02-556-330 | 8 | 0 | 02-556-384 | 8 | 0 |
| 02-556-332 | 4 | 4 | 02-556-386 | 6 | 2 |
| 02-556-334 | 12 | 0 | 02-556-392 | 9 | 0 |
| 02-556-336 | 12 | 0 | | | |



FIGURE 1

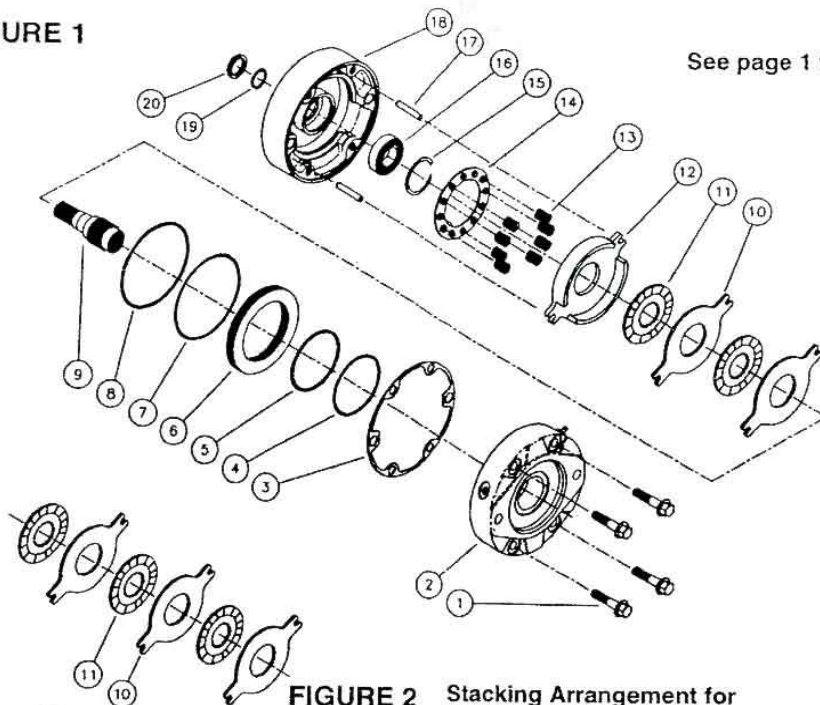

See page 1 for items included in kits.

FIGURE 2 Stacking Arrangement for Models 02-556-358, 02-556-364, 02-556-376, 02-556-380, 02-556-382, 02-556-384, 02-556-386, 02-556-392

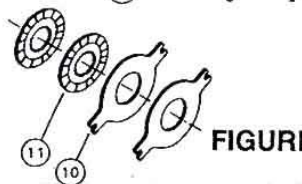

FIGURE 3 Stacking Arrangement for Models 02-556-322, 02-556-330, 02-556-346, 02-556-366

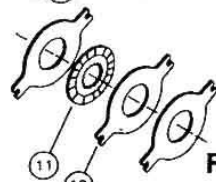

FIGURE 4 Stacking Arrangement for Model 02-556-372

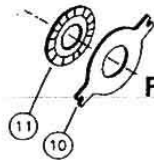

FIGURE 5 Stacking Arrangement for Models 02-556-310, 02-556-312, 02-556-368

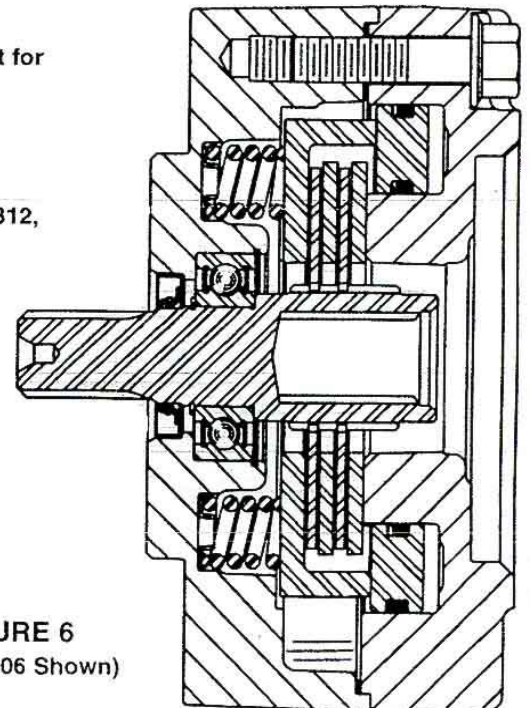

FIGURE 6 (02-556-306 Shown)

**BLEEDING**

1. Install brake in system and connect pressure lines.
2. Bleed pressure release section of brake by pressurizing side inlet port and allowing air to escape from top port. Pressure should not exceed 6.9 bar (100 psi) during bleeding.
3. Apply sufficient pressure to release brake and check for proper operation in system.

SERVICE DIAGNOSIS

| PROBLEM | CAUSE | EXPLANATION | ACTION |
|-------------------------|--|--|---|
| Brake slips | Excessive pressure in hydraulic system | If there is back pressure in the actuation line of the brake, holding torque will be reduced. | Check filters, hose size, restrictions in other hydraulic components. |
| | Oil in brake if designed for dry use | Wet linings generate 67% of the dry torque rating. If the brake has oil in it, check the type of oil hydraulic or gearbox. 1. Gearbox oil 2. Hydraulic oil | Replace oil seal in brake Check motor seal Check piston seals Note: Internal components will need to be inspected, cleaned and replaced as required. |
| | Disc plates worn | The thickness of the disc stack sets the torque level. A thin stack reduces torque. | Check disc thickness. |
| | Springs broken or have taken a permanent set | Broken or set springs can cause reduced torque - a rare occurrence. | Check release pressure. (See spring replacement) |
| Brake drags or runs hot | Low actuation pressure | The brake should be pressurized to minimum of 1.38 bar (20 psi) over the full release pressure under normal operating conditions. Lower pressures will cause the brake to drag thus generating heat. | Place pressure gauge in bleed port & check pressure with system on. |
| | Bearing failure | If the bearing should fail, a large amount of drag can be generated. | Replace bearing. |
| Brake will not release | Stuck or clogged valve | Brakes are designed to come on when system pressure drops below stated release pressure. If pressure cannot get to brake, the brake will not release. | Place pressure gauge in bleed port - check for adequate pressure. Replace defective line or component. |
| | Bad o-rings | If release piston will not hold pressure, brake will not release. | Replace o-rings. |
| | Discs frozen | These brakes are designed for only limited dynamic braking. A severe emergency stop or prolonged reduced release pressure operation may result in this type of damage. | Replace disc stack. |

MICO could not possibly know of and give advice with respect to all conceivable applications in which this product may be used and the possible hazards and/or results of each application. MICO has not undertaken any such wide evaluation. Therefore, anyone who uses an application which is not recommended by the manufacturer, first must completely satisfy himself that a danger will not be created by the application selected, or by the particular model of our product that is selected for the application.

MICO has made every attempt to present accurate information in catalogs, brochures and other printed material. MICO can accept no responsibility for errors from unintentional oversights that may exist. Due to a continuous program of product improvement, both materials and specifications are subject to change without notice or obligation.

MICO is a registered trademark of MICO, Incorporated. MICO is registered in the U.S. Patent and Trademark Office as well as in Canada, Great Britain, South Korea, Australia, and Japan.

MICO, Incorporated

1911 Lee Boulevard (Zip Code 56003-2507)
P.O. Box 8118 / North Mankato, MN U.S.A. 56002-8118
☎ 507.625.6426 Facsimile 507.625.3212

MICO West Division

701 East Francis Street (Zip Code 91761-5514)
P.O. Box 9058 / Ontario, CA U.S.A. 91762-9058
☎ 909.947.4077 Facsimile 909.947.6054





SERVICE TRUCKS INT'L

TIGER CRANE WARRANTY

S.T.I. warrants to consumer, each new S.T.I./Tiger Crane sold by it to be free, under normal use and service, from defects in material and workmanship. Terms of warranty are:

3 YEARS - From date of sale to the Original Purchaser: base plate weldment, turret assembly and structural integrity of the crane boom assembly.

1 YEAR - From date of sale to the Original Purchaser: electrical & hydraulic components

This warranty, as described above, is expressly limited to the repair, or at S.T.I.'S option, replacement of parts proven to S.T.I.'S satisfaction to be defective which are returned, F.O.B. customer location. All parts which are repaired or replaced under the terms of this warranty will be shipped, F.O.B. Destination, from S.T.I.'S factory in Sioux Center, IA. STI will pay standard freight expense of parts to and from the owner. Faster freight service is available, with the owner paying the difference between standard and preferred method of owner. Freight of whole goods to or from the factory is the owner's expense, regardless if they fall under warranty or not. All warranty decisions will be final!

This warranty does not cover the cost of labor, parts or transportation charges when any party other than S.T.I. performs the replacement or repair of parts claimed to be defective, nor shall this warranty apply to an S.T.I. product upon which any alterations or repairs other than normal maintenance have been made without the written approval of S.T.I.

S.T.I. shall in no event be liable for consequential damages, lost profits or contingent liabilities arising out of the failure of any S.T.I. product or parts to operate properly.

WARRANTY CARD MUST BE FILLED OUT AND RETURNED TO FACTORY IMMEDIATELY UPON RECEIPT OF EQUIPMENT TO INSURE WARRANTY COVERAGE.

THIS WARRANTY IS EXTENDED ONLY TO THE INITIAL PURCHASER FROM AN AUTHORIZED S.T.I./TIGER CRANE DISTRIBUTOR AND MAY NOT BE REASSIGNED. THIS WARRANTY IS EXPRESSLY IN LIEU OF ANY OTHER WARRANTIES EXPRESSED OR IMPLIED, INCLUDING ANY IMPLIED WARRANTIES OF MERCHANTABILITY OR FOR A PARTICULAR PURPOSE AND S.T.I. NEITHER ASSUMES OR AUTHORIZES ANY OTHER PERSON TO ASSUME FOR IT ANY OTHER LIABILITY. THERE ARE NO WARRANTIES, WHICH EXTEND BEYOND THE DESCRIPTION OF THE FACE HEREOF.

We reserve the right to make improvements to any of our products without notice or obligation regarding models previously sold.

CRANE SERIAL # _____

Effective 08/01