



STINGER™ 3470

Boom Truck Crane

FEATURES

- 34,000 lb (13 607 kg) maximum lifting capacity
- 80' (24.38 m) maximum tip height
- 120' (36.57 m) maximum tip height with 24-40' (7.31-12.19 m) jib
- 27-70' (82.30-21.34 m) three-section full power fully synchronized boom
- Exclusive color coded boom and load charts
- Easy-to-install optional 24' (7.31 m) one stage or 24-40' (7.31-12.19 m) two stage telescoping jib, man baskets or work platform increase job capacities
- Electronic Load Moment Indicator and anti-twoblock device standard
- Externally located planetary rotation drive for easy accessibility for maintenance
- 2-speed planetary winch has 9,600 lb (4 350 kg) maximum permissible 1 part line, 33,600 lb (15 240 kg) breaking strength, 186 ft/min (57 m/min) maximum line speed
- Dual control station with direct mechanically controlled hydraulic system
- 70 gal (266 L) capacity hydraulic tank



Machines shown may have optional equipment.

SPECIFICATION

Boom

27-70' (82.30-21.34 m) three-section full power fully synchronized boom. Patented keel boom design utilizes a keel shaped base plate combined with a deep, four plate boom section to optimize strength / rigidity-to-height ratio. Exclusive, patented color-coded boom and load charts allow the operator to easily determine boom extension, boom angle and load capacity. Maximum tip height with three-section 27-70' (82.30-21.34 m) boom is 80' (24.38 m). Maximum tip height with optional two-stage 24-40' (7.31-12.19 m) jib is 120' (36.57 m).

Winch

Hydraulic winch with gear motor and planetary reduction gearing provides 2-speed operation. First layer rope pull of 11,400 lb (5 170 kg). Wire rope size is 9/16" (14 mm) with 33,600 lb (15 240 kg) breaking strength.

Operating Speeds

Mainframe / turret assembly planetary gear rotation provides 180° rotation (370° with optional front bumper outrigger). Swing rotation is 55 seconds. Boom up/down is 25/16 seconds and boom extend/retract is 61/29 seconds.

Hydraulics

Three-section pump allows the operator to perform simultaneous crane operations (winch, boom and swing). Capacities are 32, 17 and 8 gpm (122, 64 and 30 L/m). Hydraulic tank capacity is 70 gpm (266 L/m).

Controls

Fully proportional, excellent metering characteristics for precise boom movements. Independent outrigger controls allow the crane to be stable and level in rigorous working conditions. Load Moment Indication System has audio alarm and functional shut down when operator encounters an overload situation.

Outriggers

Front outriggers are Link-Type. The maximum width over main outrigger pad is 20' 5" (6.23 m), main outrigger spread at maximum ground penetration is 20' (6.10 m). Rear outriggers are A-Frame. The maximum width over auxiliary outrigger pads is 10' 2" (3.09 m).

Subframe

Single fabricated, closed-box style subframe yields greater strength and rigidity. Wheelbase for standard truck crane mounting configuration is 242" (6.15 m).

OPTIONS AND ACCESSORIES

Terex Stinger offers a wide range of options and accessories to customize your truck crane to your exact needs.

These include:

- Single and two-stage jibs
- Multi-part load blocks
- Plain winch with 2 speed motor
- Auxiliary winch
- Rotation-resistant load line
- Heavy duty wood flatbeds
- Extra heavy duty wood flatbeds
- Extra heavy duty steel flatbeds
- Radio remote controls
- One-man or two-man baskets
- Self-leveling work platform
- Winch drum tensioner
- Continuous rotation
- Oil cooler
- Single front bumper outrigger (required for 370° or continuous rotation)
- Hydraulic hose reel
- Hydraulic auxiliary tool circuit for cab
- Tool Cab



STINGER 3470 LOAD RATINGS

CAUTION: Do not use this specification sheet as a load rating chart. The format of data is not consistent with the machine chart and may be subject to change.

Maximum Load Chart in pounds (lbs) with fully extended outriggers

OPERATING RADIUS (Ft)	BOOM LENGTH												OPERATING RADIUS (Ft)			
	27 Ft		34 Ft		43 Ft		52 Ft		61 Ft		70 Ft					
	LOADED BOOM ANGLE (DEG)	LOAD RATING (LB)	LOADED BOOM ANGLE (DEG)	LOAD RATING (LB)	LOADED BOOM ANGLE (DEG)	LOAD RATING (LB)	LOADED BOOM ANGLE (DEG)	LOAD RATING (LB)	LOADED BOOM ANGLE (DEG)	LOAD RATING (LB)	LOADED BOOM ANGLE (DEG)	LOAD RATING (LB)				
5	77	34,000*											5			
10	66	21,100*	71	17,100*	75	16,000*	78	15,700*					10			
15	54	15,100*	62	14,000*	68	12,100*	72	11,100*	75	10,800*	77	9,600*	15			
20	39	11,100*	51	10,100*	61	9,100*	66	8,600*	71	8,200*	73	7,300*	20			
25	17	7,900*	40	7,700*	53	7,100*	61	6,900*	66	6,600*	69	5,900*	25			
30			23	6,500*	44	6,100*	54	5,600*	60	5,300*	64	4,900*	30			
35					33	4,800*	47	4,700*	54	4,600*	60	4,150*	35			
40	BT & RM Models				16	3,500*	38	4,100*	48	3,900*	55	3,550*	40			
45							27	3,250*	41	3,200*	49	3,050*	45			
50	NOTE: STRUCTURAL STRENGTH RATINGS IN CHART ARE INDICATED WITH AN ASTERISK (*)						9	2,950*	33	2,800*	44	2,650*	50			
55												23	2,500*	37	2,350*	55
60														29	1,900*	60
65											19	1,700*	65			

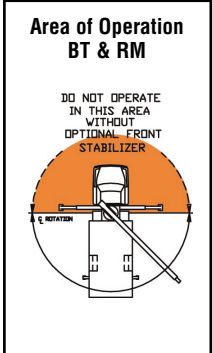

- Deductions from rated loads for load handling devices BT & RM**
- Overhaul Ball:** 125 lbs
 - 1 Tip Load Block:** 200 lbs
 - 2 Tip Load Block:** 230 lbs
 - Aux Tip:** 50 lbs

Stowed Jib Deductions (Pounds)

450	360	260	230	200	175
-----	-----	-----	-----	-----	-----

JIB CAPACITIES FOR ALL BOOM LENGTHS

VERIFY OPERATIONAL MODE SETTING ON LMI DISPLAY BEFORE LIFTING WITH JIB

Loaded Boom Angle	35°	40°	45°	50°	55°	60°	65°	70°	75°	80°
Retracted 24 ft. Jib	700	825	1,000	1,150	1,340	1,600	1,900	2,300	3,100	4,160
Extended 40 ft. Jib	520	580	650	730	810	930	1,080	1,400	1,810	2,260

General Notes

- The operator must read and understand the Owner's Manual before operating this crane.
- Positioning or operation of crane beyond areas shown on this chart is not intended or approved except where specified in Owner's Manual.
- Loaded boom angles at specified boom lengths give only an approximation of the operating radius. The boom angle before loading should be greater to account for deflections. Do not exceed the operating radius for rated loads.
- Use rating of next longer boom for boom lengths not shown. Use rating of next greater radius for load radii not shown.
- Boom must be fully retracted when jib is erected before lowering below minimum angle. Retracted jib has no lifting capacity below a 50° boom angle.
- Use rating of next lower boom angle for boom angles not shown on jib load rating chart.
- Lifting off the main boom point while the swing around jib is erected is not intended or approved.
- Do not lower boom into this area, as hydraulic pressure will not allow raising the boom without retracting boom first.
- Crane load ratings on outriggers are based on freely suspended loads with the machine leveled and standing on a firm uniform supporting surface. No attempt shall be made to move a load horizontally on the ground in any direction.
- Practical working loads depend on supporting surface, wind and other factors affecting stability such as hazardous surroundings, experience of personnel, and proper handling, must all be taken into account by the operator.
- The maximum load which may be telescoped

is limited by hydraulic pressure, boom angle, and boom lubrication. It is safe to attempt to telescope any load within the limits of the load rating chart.

INFORMATION

- Deductions must be made from rated loads for stowed jib, optional attachments, hooks and loadblocks (see deduction chart). Weights of slings and other load handling devices shall be considered a part of the load.
- Crane load ratings with outriggers are based on outriggers and stabilizers extended and set with all load removed from the carrier wheels.
- Load ratings do not exceed 85% of tipping load.

DEFINITIONS

- Operating radius is the horizontal distance from the axis of rotation to the center of the vertical hoist line or load hook with load suspended.
- Loaded boom angle as shown in the Load Ratings Chart is the included angle between the horizontal and longitudinal axes of the boom base after lifting rated load at rated radius.

Range Diagram (27 – 70 Ft boom)

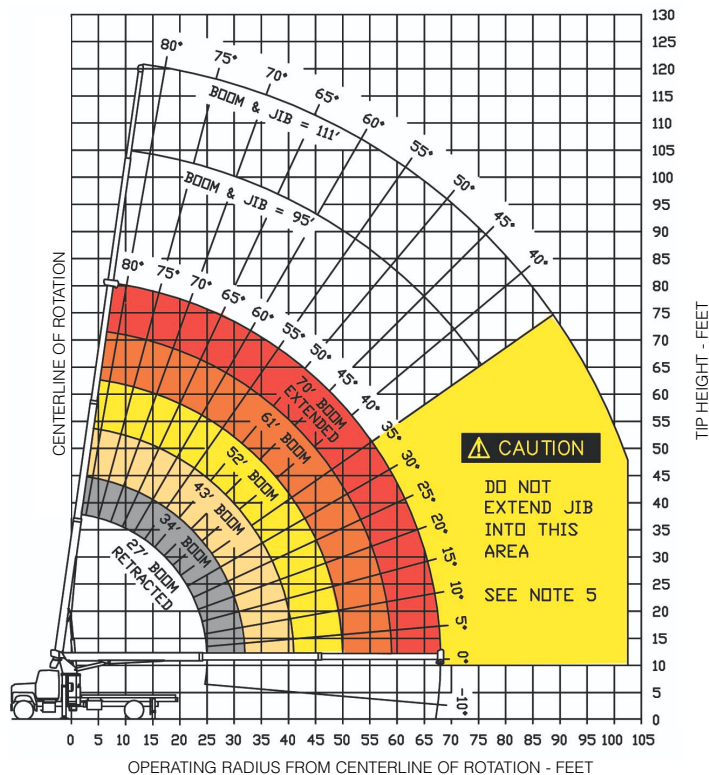

**WINCH DATA**

		1 Part Line	2 Part Line	3 Part Line	4 Part Line
Winch	Cable Supplied	Lift and Speed	Lift and Speed	Lift and Speed	Lift and Speed
Standard Stationary Winch	9/16" Diam. IWRC XIP	9,600 lb. 186 fpm*	19,200 lb. 93 fpm*	28,800 lb. 62 fpm*	34,000 lb. 45.5 fpm*
	9/16" Diam. Rotation Resistant	6,720 lb. 186 fpm*	13,440 lb. 93 fpm*	20,160 lb. 62 fpm*	26,880 lb. 45.5 fpm*

Block Type	Rating
Overhaul Ball	6.5 ton (5.9 mt)
1 Sheave Block	17 ton (15.4 mt)

CAUTION

Overload and anti-two-block systems must be in good operating condition before operating crane. Refer to Owners Manual.

Keep at least 3 wraps of loadline on drum at all times.

Use only 9/16" diameter cable with 33,600 lb. breaking strength on this machine.

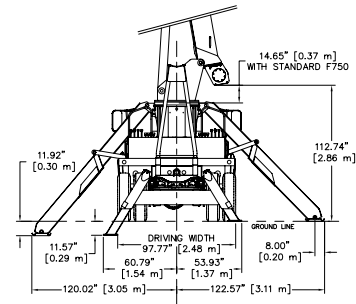
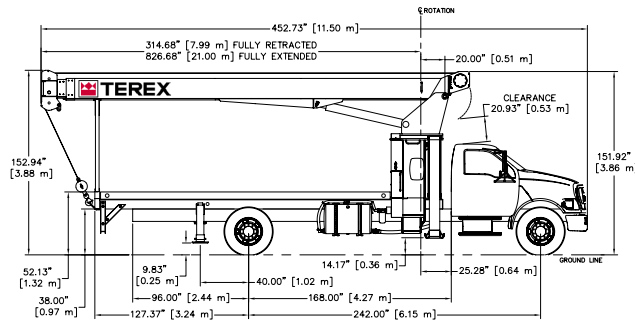
2 DIFFERENT MOUNTING CONFIGURATIONS**• Behind Cab Mounting Configuration****DIMENSIONAL DATA****CARRIER PROVIDED BY TEREX****STINGER BT3470 - Behind Cab Mounting Configuration**

Manufacturer	2005 Ford F-750 4 x 2 Chassis
Standard Engine	Caterpillar C-7 7.2 L I-6
Standard Horsepower	210 hp @ 2,500 rpm
Standard Torque	605 lb. Ft. @ 1,440 rpm
Full Tank Capacity	45 gal (170 L)

• Standard Transmission	Spicer ES066-7B
Speed Standard Transmission	Manual 7-speed
Max Speed Standard Transmission	74 mph (118.4 km/h)
Max Gradeability Standard Transmission	17.7% in 1st 15.8% in Rev

• Optional Transmission	Allison
Speed Optional Transmission	Automatic 5-speed
Max Speed Optional Transmission	74 mph (118.4 km/h)
Max Gradeability Optional Transmission	21.1% in 1st 30.5% in Rev

Gross Vehicle Weight Rating	33,000 lb (14 969 kg)
Front Axle Weight Rating	12,000 lb (5 443 kg)
Rear Axle Weight Rating	21,000 lb (9 525 kg)
Front Tires	22.5" x 8.5" 11R22.5 G Goodyear G159
Rear Tires	22.5" x 7.5" 11R22.5 G Goodyear G167A
Brakes	Air, Hydraulic Anti-Lock System
Exhaust Position	Horizontal Left Side

Included Options:

Fuel tank (45 gal)-175 L
Power steering
Electric Horn
Factory A/C
Power Port (Cigar lighter)
AM/FM Radio w/ Clock
Dual West Coast Stainless
Standard Factory Warranty

CHASSIS RECOMMENDATIONS-MINIMUM REQUIREMENT**STINGER BT3470 - Behind Cab Mounting Configuration**

Combined Axle Weight Rating	33,000 lb (14 969 kg)
Front Axle Weight Rating	12,000 lb (5 443 kg)
Rear Axle Weight Rating	21,000 lb (9 525 kg)
Wheel base	242" (6.15 m)
Cab to Axle	168" (4.27 m)
Afterframe	96" (2.44 m)
Frame Section Modulus	16.98 in ³ (278 cm ³)
RBM per Frame Rail	1,400,000 in/lb (16 130 kg/m)
Frame Height (Unloaded)	40" (7.62 m)
Exhaust Position	Horizontal Left Side



STINGER™ 3470

Boom Truck Crane

2 DIFFERENT MOUNTING CONFIGURATIONS

• Rear Mount Configuration

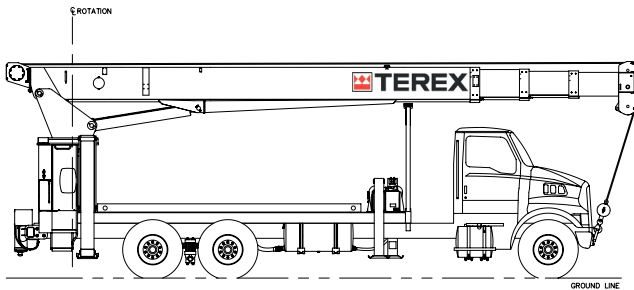

CARRIER PROVIDED BY TEREX

STINGER RM3470 – Rear Mount Configuration

Manufacturer	2004 Sterling LT7501 6 x 4 (60 000)
Standard Engine	Caterpillar C-7 7.2 L I-6
Standard Horsepower	300 hp @ 1,440 rpm
Standard Torque	860 lb. Ft. @ 1,500 rpm
Full Tank Capacity	60 gal (227 L)

• Standard Transmission	Eaton Fuller RT-8908LL
Speed Standard Transmission	Manual 10-speed
Max Speed Standard Transmission	74 mph (120 km/h)
Max Gradeability Standard Transmission	54%

• Optional Transmission	Allison
Speed Optional Transmission	Automatic 6 speeds
Max Speed Optional Transmission	74 mph (120 km/h)
Max Gradeability Optional Transmission	17%

Gross Vehicle Weight (without crane)	60,000 lb (27 210 kg)
Front Axle Weight Rating (without crane)	20,000lb (9 067kg)
Rear Axle Weight Rating (without crane)	40,000 lb (18 144 kg)
Front Tires	425/65R 22.5 Michelin XZY (20 ply)
Rear Tires	11R 22.5 Michelin XDE M/S (14 ply)
Brakes	Air, Hydraulic Anti-Lock System
Exhaust Position	Horizontal Left Side

Included Options:

Fuel tank (45 gal-175 L)
Power steering
Electric Horn
Factory A/C
Power Port (Cigar lighter)
AM/FM Radio w/ Clock
Dual West Coast Stainless
Standard Factory Warranty

CHASSIS RECOMMENDATIONS-MINIMUM REQUIREMENT

STINGER RM3470 – Rear Mount Configuration

Combined Axle Weight Rating	60,000 lb (27 210 kg)
Front Axle Weight Rating	20,000 lb (9 067 kg)
Rear Axle Weight Rating	40,000 lb (18 144 kg)
Wheel base	261" (6.62 m)
Cab to Axle	192" (4.87 m)
Afterframe	114" (2.89 m)
Frame Section Modulus	30.00 in ³ (4.91 cm ³)
RBM per Frame Rail	1,800,000 in/lb (16 130 kg/m)
Frame Height (Unloaded)	40" (7.62 m)
Exhaust Position	Horizontal Left Side

For more information, product demonstration, or details on purchase, lease and rental plans, please contact your local Terex Cranes dealer.

We reserve the right to amend these specifications at any time without notice. The only warranty applicable is our standard written warranty applicable to the particular product and sale. We make no other warranty, expressed or implied.

Simple, available and
cost effective™



Waverly Operations
106 12th Street S.E.
Waverly, IA 50677-9466 USA
TEL: (319) 352-3920
FAX: (319) 352-5727
E-MAIL: inquire@terexwaverly.com
WEB: <http://www.terex.com>