



SEINEBOGEN

NEU!
NEW!



119 kW



20 t



20 m

620 HD

Heavy Duty Seilbagger / Kran
Duty Cycle Crawler Crane



SENEBOGEN[®]

620 HD





SENEBOGEN[®]

620 HD

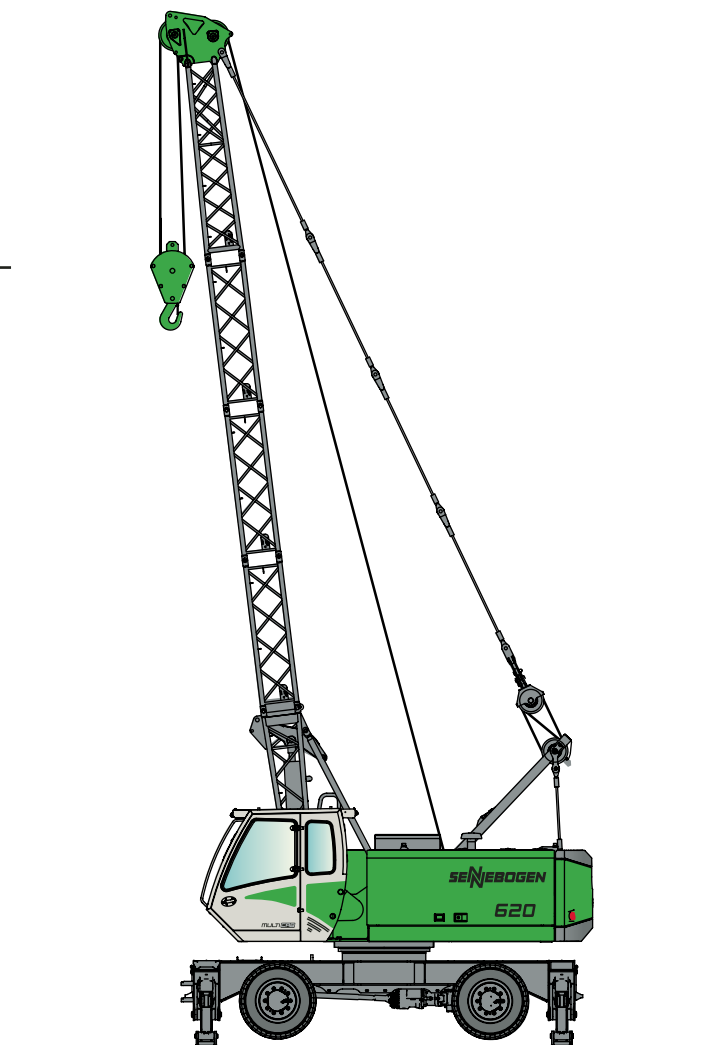
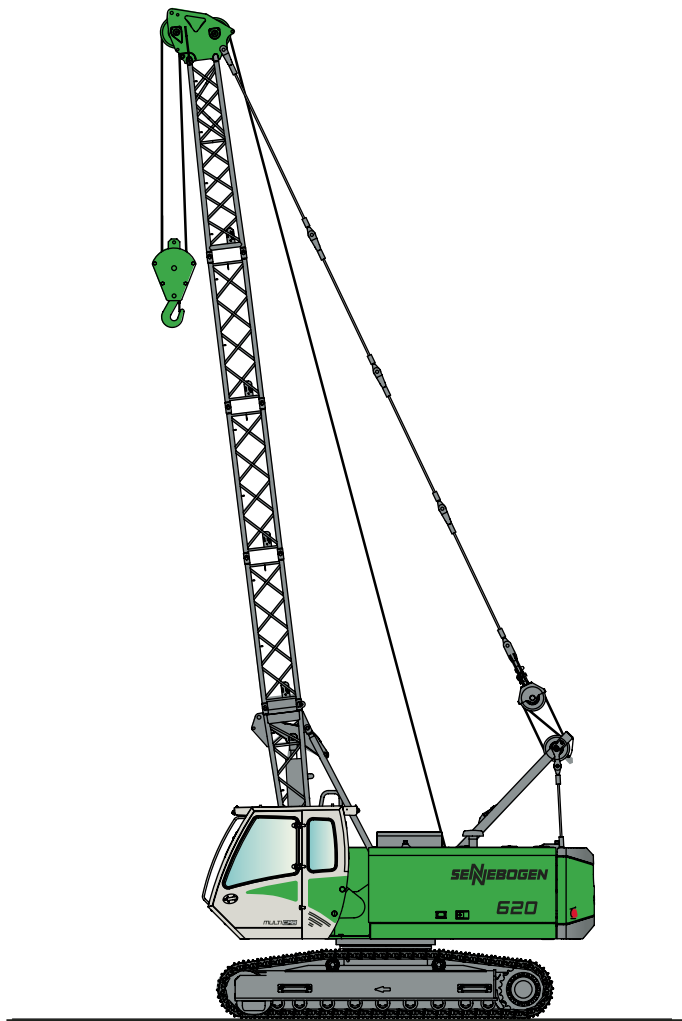

**SENNEBOGEN**[®]**620 HD****Technische Daten****Diesel-Motor**

Model	Cummins QSB 4.5-C160
Leistung	119 kW/162 PS bei 2200 min⁻¹
Direkteinspritzung, turboaufgeladen, Ladeluftkühlung, emissionsreduziert	
Kühlung	wassergekühlt
Luftfilter	Trockenfilter mit Vorabscheider, automatischer Staubaustrag, Haupt- und Sicherheitselement, Verschmutzungsanzeige
Kraftstofftankinhalt	325 l
Elektrische Anlage	24 V
Elektroinstallation	einfach und sehr übersichtlich
Batterien	2 x 110 Ah, Hauptschalter

Hydraulik-System

Load-Sensing/LUDV Hydrauliksystem	
Pumpentyp	Verstell-Kolbenpumpe in Schrägscheibenbauart Lastdruckunabhängige Volumensteuerung für gleichzeitige, unabhängige Steuerung der Arbeitsfunktionen
Pumpenregelung	Nullhubregelung, Bedarfsstromsteuerung - Die Pumpen fördern nur so viel Öl, wie auch tatsächlich verbraucht wird. Druckabscheidung, Grenzlastregelung
Fördermengen max.	315 l/min
Betriebsdruck max.	330 bar
Zusatzhydraulikpaket, optional	
Filtration	Hochleistungsfiltration mit Langzeitwechselintervall, Verschmutzungsanzeige SENNEBOGEN HydroClean Feinfiltersystem mit Wasserabscheidung (option),
Hydrauliktank	325 l / 280 l
Steuerung	Proportionale, feinfühlig hydraulische Servosteuerung der Bewegungen, 2 Servo Joysticks für die Arbeitsfunktionen, Zusatzfunktionen über Schalter und Fußpedale - ergonomisch und übersichtlich angeordnet

Hohe Energie-Effizienz durch großdimensionierte Hydraulikventile und Leitungen.

Zentrale Messanschlüsse für Hydrauliktest

Sicherheitsventile in den Hydraulikkreisen

Drehwerk

Kompaktplanetengetriebe mit Schrägachsen-Hydraulikmotor, integrierte Bremsventile	
Parkbremse	Lamellenbremse, über Federn wirkend
Drehkranz	starker Drehkranz, abgedichtet
Drehgeschwindigkeit	0-4,0 min ⁻¹ , stufenlos

Oberwagen

Bauart	Verwindungssteife Kastenbauweise, präzisionsbearbeitet, Bronzebüchsen für Auslegerlagerung, klare, sehr servicefreundliche Konzeption, in Längsrichtung eingebauter Motor
--------	---

Kühlsystem

großdimensioniertes Kühlsystem für Motor und Hydraulik. Sehr energieeffizient und lärmreduziert durch thermisch geregelten Lüfterantrieb

Winde 1 - Winde 2

Antrieb der Winden über hochdruckgeregelte Verstell-Hydraulikmotore, dadurch immer optimale Zugkraft-Geschwindigkeitregelung, hydraulische Senk-Bremsventile für feinfühliges, verschleißfreies Abbremsen. Starke Ölbad-Planetengetriebe, wartungsarm, Kran- und Freifallbremse sind federbelastete, wartungsfreie, verschleißsarme Lamellenbremsen im Ölbad laufend, ölgekühlt

Winden	6 t
Seilzug (Nennlast) 1.Lage	60 kN
Seildurchmesser mm	16
Seilgeschw. m/min	0-100

Arbeitsausrüstung

Konstruktion	Jahrzehntelange Erfahrung und modernste Computersimulation garantieren ein Höchstmaß an Stabilität und Lebensdauer
Auslegerverstellwinde	Antrieb über Schrägachsen-Hydraulikmotor mit Kompaktplanetengetriebe, Zugkraft 30 kN, Seildurchmesser 14 mm
Sicherheitsbremse Kransicherheit	Lamellenbremse, über Federn wirkend Neuste Generation der Lastmomentüberwachung, Graphic Display mit Anzeige aller wichtigen Daten, Hubendschalter, Überdruckventile, Seilablaufsicherung

Unterwagen 620 HD Raupe

Konstruktion	Sehr starker, Raupenunterwagen, mit integrierten geschützten Antriebsgetrieben. Starre Spurbreite oder optional hydraulisch teleskopierbar.
Fahrtrieb	Starker Fahrtrieb mit Axialkolben-Hydraulikmotor und direkt angebautes automatisch wirkendem Bremsventil und Kompaktplanetengetriebe je Fahrwerksseite
Parkbremse	Lamellenbremse, über Federn wirkend
Laufwerk	Wartungsfreies Traktorenlaufwerk mit hydraulischer Kettenspannung, 3-Steg-Bodenplatten, Flachbodenplatten optional
Fahrgeschwindigkeit	0-2,5 km/h

Unterwagen 620 M Mobil

Konstruktion	Starker Mobilunterwagen mit integrierter 4-Punkt Prätzenabstützung, Lenkachse als hydraulisch feststellbare Pendelachse. Pendelachszylinder mit Rohrbruchsicherheitsventilen, SENNEBOGEN MP26
Antrieb	Allradantrieb über Verstellhydraulikmotor mit direkt angebautes, automatisch wirkendem Bremsventil und 2-Stufen Lastschaltgetriebe. Starke 40t Planetenachsen mit integriertem Lenkzylinder, Lamellenbremse als Betriebsbremse im 2-Kreis System.
Parkbremse	Lamellenbremse über Federn wirkend
Bereifung	10.00-20, 8-fach
Fahrgeschwindigkeit	0-7 km/h Stufe I, 0-20 km/h Stufe II

SENNEBOGEN MULTICAB

SENNEBOGEN multicab, exzellente Ergonomie, Heiz-Klimaautomatik mit Temperaturvorwahl und Frischluft / Umluftfilter, Komfortsitz optional einstellbar, ausgezeichnete Rundumsicht, SENNEBOGEN Diagnostic System

Technische Änderungen vorbehalten!

**SENNEBOGEN**[®]**620 HD****Specifications****Diesel engine**

Model	Cummins QSB 4.5-C160
Output	119 kW/162 PS bei 2200 min⁻¹
Direct injection, turbo charged, intercooler, reduced emission	
Cooling	Water cooled
Air filter	Dry air filter with precleaner, automatic dust discharge, main and safety element, pollution indicator
Fuel tank	325 l
Electric system	24 V
Electric installation	simple and very clear design
Batteries	2 x 110 Ah, main switch

Hydraulic system

Load-Sensing/LUDV system	
Hydraulic pump	Variable displacement piston pump, swashplate Type, load sensing regulation for parallel, independent operation of the working function
Pump regulation	Zero flow regulation, flow on demand control - The pumps only supplying the required oil Pressure cut off, speed sensing regulation
Oil flow max.	315 l/min
Pressure max.	330 bar
Additional hydraulic package, optional	
Filtration	High-efficiency filtration with long-time change interval, pollution indicator SENNEBOGEN HydroClean micro filtration with water separation, (optional)
Hydraulic tank	325 l / 280 l
Steering	Proportional, servo hydraulics, precise control of the working functions, 2 servo joysticks for operating movements, additional functions through switches and foot pedals - in a clear and ergonomical layout

High efficiency through well sized hydraulic valves and lines

Central test ports for hydraulic circuits

Safety valves for all hydraulic circuits

Swing drive

Compact planetary reduction gear with hydraulic piston motor, integrated brake valves	
Parking brake	Multi-disc brake, spring-loaded
Swing bearing	Strong bearing, sealed
Swing speed	0-4,0 rpm, stepless

Upper carriage

Design	Torsion resistant box type design, precision machined, brass bushes for the boom pivot Clear, very servicefriendly design longitudinal installation of the engine
--------	---

Cooling system

Large sized cooling system for the engine and hydraulics. Very energy efficient and noise emission reduced through thermally controlled drive

Winch 1 - Winch 2

Each winch is driven independently by a directly flanged pressure regulated variable displacement hydraulic piston motor, this ensures at any time the best regulation of line speed and line pull. Hydraulic brake valves for wear resistant braking of loads. Strong low-maintenance oil bath planetary gears. The clutch and brake functions are affected by large-dimensioned, maintenance-free, low-wearing, oil-lubricated multiple disc brakes, oil cooled.

Winches	6 t
Single line pull 1.Layer	60 kN
Rope dia. mm	16
Line speed m/min	0-100

Working equipment

Design	Decades of experience and state-of-the-art computer simulation guarantes highest stability and durability
Boom hoist winch	Axial piston hydraulic motor, planetary gear, 30 kN line pull 14 mm rope diameter
Safety brake	Spring-applied multi-disc brake
Crane safety	State-of-the-art safe load indicator with graphic display, hoist limit switch, pressure relief valves, rope limit switch

Undercarriage 620 HD Crawler

Design	Very strong, crawler undercarriage with integrated protected drives Fixed track gauge, optional hydraulically extendable.
Drive system	High traction force through piston motors with directly mounted automatic brake valves and planetary gears at each track side
Parking brake	Multi-disc brake, spring-loaded
Tracks	Maintenance-free track type with hydraulic track tensioning system, triple grouser shoes. Flat shoes optional
Travel speed	0-2.5 km/h

Undercarriage 620 M Mobil

Design	Strong, rubber tired undercarriage with integrated 4-point outriggers, steering axle as oscillating axle lockable. Oscillating axle cylinders with safety check valves, SENNEBOGEN MP26
Drive	All-wheel drive via variable displacement piston motor with directly mounted automatic brake valve and 2-stage power shift gear. Strong 40t axles with integrated steering cylinder. Wet multi disk brakes in 2 circuit system.
Parking brake	Multi disc brake, spring loaded
Tires	10.00-20, 8 tires
Travel speed	0-7 km/h gear I, 0-20 km/h gear II

SENNEBOGEN MULTICAB

SENNEBOGEN multicab, excellent ergonomics, automatic heating/air conditioning with temperature pre-select and fresh air/recirculation filter, comfort seat optionally adjustable, excellent 360° visibility, SENNEBOGEN Diagnostics System

Subject to technical modification!



SENNEBOGEN®

620 HD

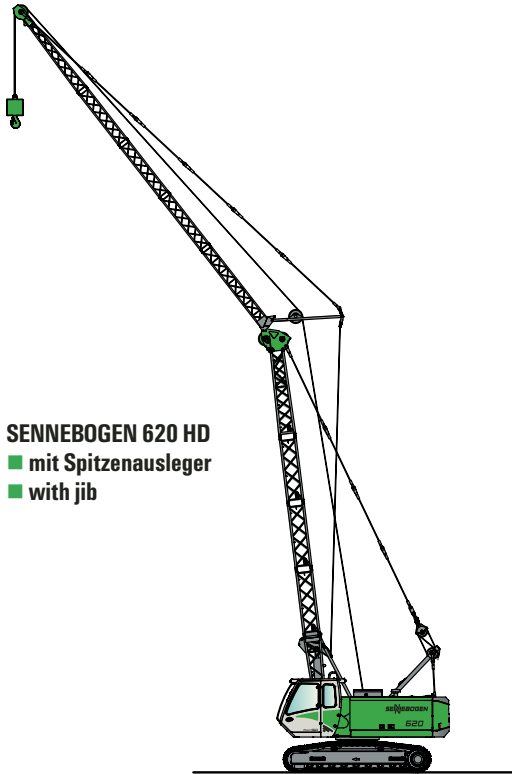

SENNEBOGEN 620 HD
■ mit Spitzenausleger
■ with jib

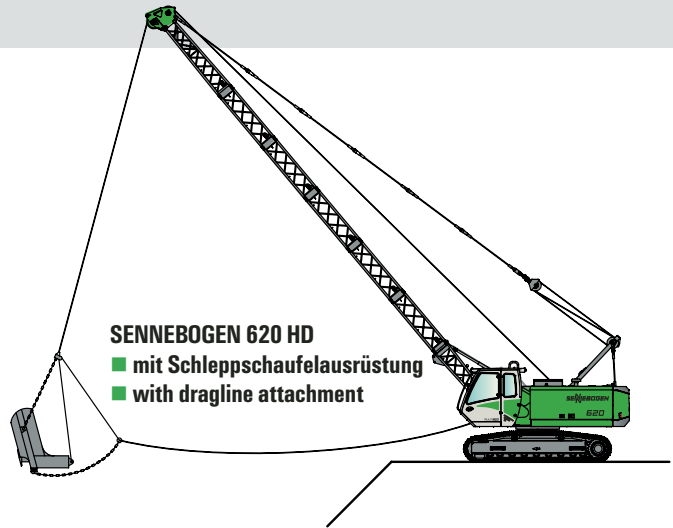

SENNEBOGEN 620 HD
■ mit Schleppschaufel­ausrüstung
■ with dragline attachment

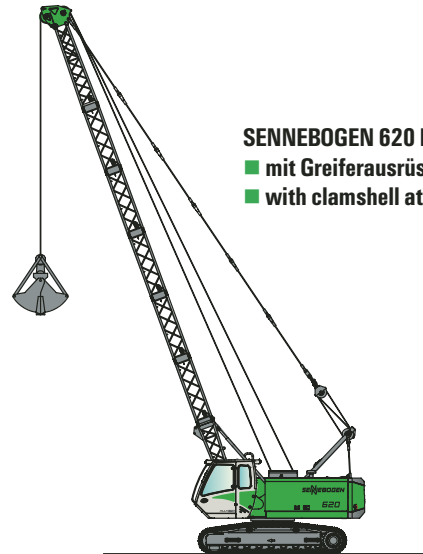

SENNEBOGEN 620 HD
■ mit Greiferausrüstung
■ with clamshell attachment

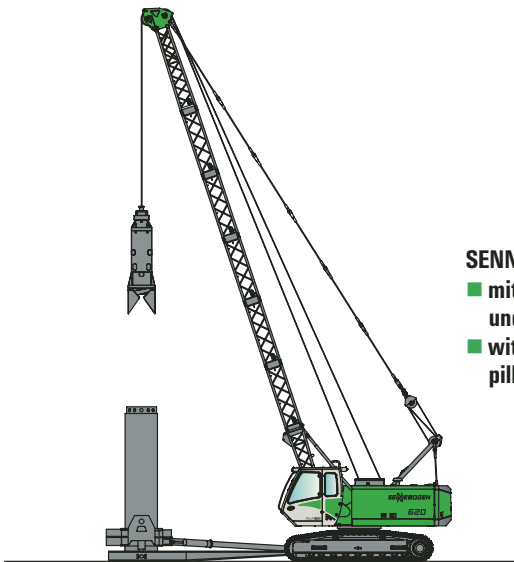

SENNEBOGEN 620 HD
■ mit Verrohrungs­maschine
und Bohrgreifer
■ with casing oscillator and
pilegrab

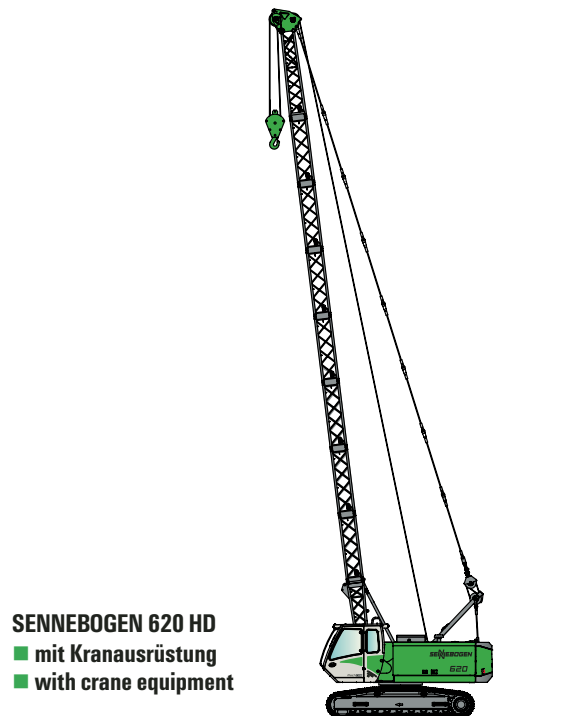

SENNEBOGEN 620 HD
■ mit Kranausrüstung
■ with crane equipment

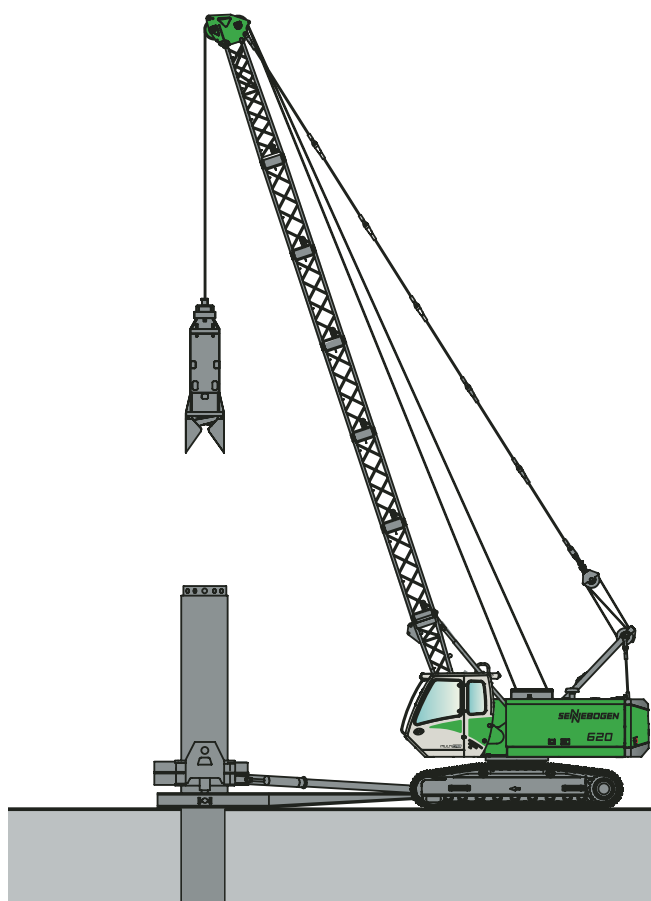
**SENNEBOGEN**[®]**620 HD****Spezialtiefbau / special foundation****Verrohrungsmaschine - casing oscillator**

Winden (kN) winches (kN)	2 x 60
Seilgeschwindigkeit (m/min) line speed (m/min)	0-110
Bohrdurchmesser (mm) bore diameter (mm)	600 / 800
Motor/engine	119 kW / 162 PS

Der „SENNEBOGEN Spirit“

- Kein Over-Engineering; Elektronik vermeiden
- Langlebigkeit, Wertstabilität, robuste Bauweise
- Ressourcenschonender Materialeinsatz
- Konstruktion und Produktion mit Fokus auf Zuverlässigkeit und Verfügbarkeit
- Hohe deutsche Qualitätsmaßstäbe an allen Komponenten

The “SENNEBOGEN Spirit”

- No over-engineering; avoid electronics
- Long service life, stability of value, robust construction
- Eco-friendly use of materials
- Construction and production with a focus on reliability and availability
- High German quality standards for all components



Greiferausrüstung / Clamshell Equipment

D-Serie

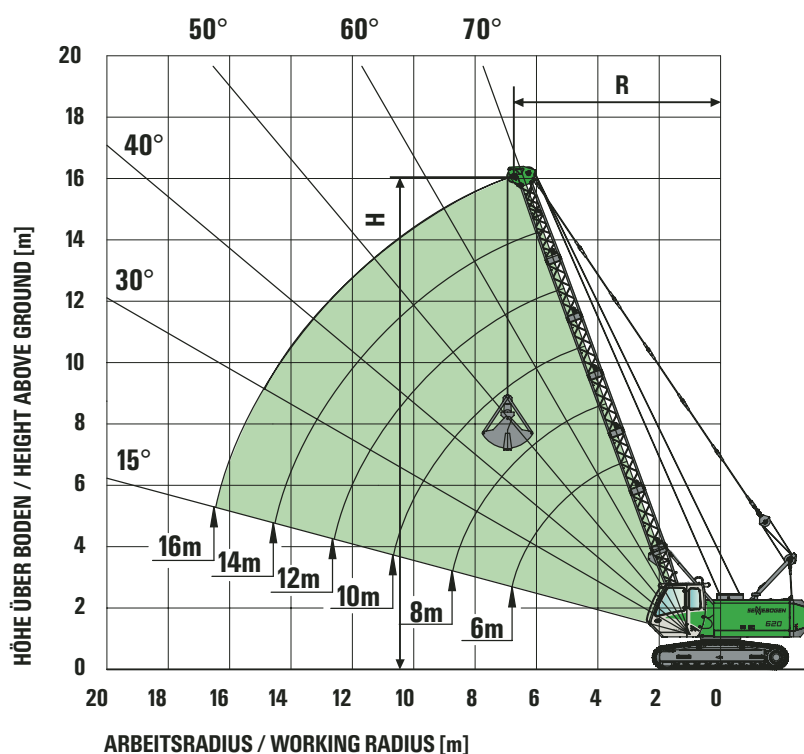

Anmerkungen:

- Die angegebenen Traglasten beinhalten das Greifergewicht und überschreiten nicht 66,7 % der Kipplast.
- Die Traglasten gelten bei max. Unterwagensepbreite.

Arbeitsbereich:

- R = Ausladung
- H = Höhe
- K = Länge des Greifers

Notes:

- For clamshell operations, bucket weight is considered part of the load and the total bucket weight plus contents must not exceed the corresponding ratings shown.
- In operation, crawlers must be extended.

Working range:

- R = Radius
- H = Height
- K = Length of grab

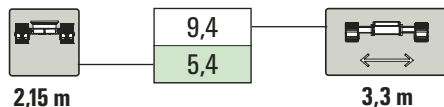

Auslegerlänge boom length	10,0 m			12,0 m			14,0 m			16,0 m		
	R	H		R	H		R	H		R	H	
Auslegerwinkel boom angle	m	m	t	m	m	t	m	m	t	m	m	t
alpha [°]												
70	4,7	10,4	9,4 5,4	5,4	12,3	7,5 4,4	6,1	14,2	6,2 3,7	6,8	16,1	5,3 3,1
65	5,5	10,1	7,3 4,3	6,3	11,9	5,9 3,5	7,2	13,7	4,8 2,9	8,0	15,5	4,1 2,4
60	6,3	9,7	6,0 3,6	7,3	11,4	4,8 2,9	8,3	13,1	3,9 2,3	9,3	14,8	3,3 1,9
55	7,0	9,2	5,1 3,1	8,1	10,8	4,1 2,4	9,3	12,4	3,3 2,0	10,4	14,1	2,8 1,6
50	7,7	8,6	4,5 2,7	8,9	10,1	3,5 2,1	10,2	11,7	2,9 1,7	11,5	13,2	2,4 1,4
45	8,3	8,0	4,0 2,4	9,7	9,4	3,2 1,9	11,1	10,8	2,6 1,5	12,5	12,2	2,1 1,2
40	8,9	7,3	3,6 2,2	10,4	8,6	2,9 1,7	11,9	9,9	2,3 1,3	13,4	11,2	1,9 1,1
35	9,4	6,6	3,4 2,0	11,0	7,8	2,6 1,6	12,6	8,9	2,1 1,2	14,3	10,1	1,7 0,9
30	9,8	5,9	3,1 1,9	11,5	6,9	2,5 1,4	13,3	7,9	2,0 1,1	15,0	8,9	1,6 0,9
25	10,2	5,1	3,0 1,8	12,0	5,9	2,3 1,4	13,8	6,8	1,9 1,0	15,6	7,6	1,5 0,8
20	10,5	4,3	2,9 1,7	12,4	5,0	2,2 1,3	14,3	5,6	1,8 1,0	16,1	6,3	1,4 0,8
15	10,7	3,4	2,8 1,7	12,7	4,0	2,1 1,3	14,6	4,5	1,7 1,0	16,5	5,0	1,4 0,7



SENEBOGEN®

620 HD

Schleppschaufel­ausrüstung / Dragline Equipment

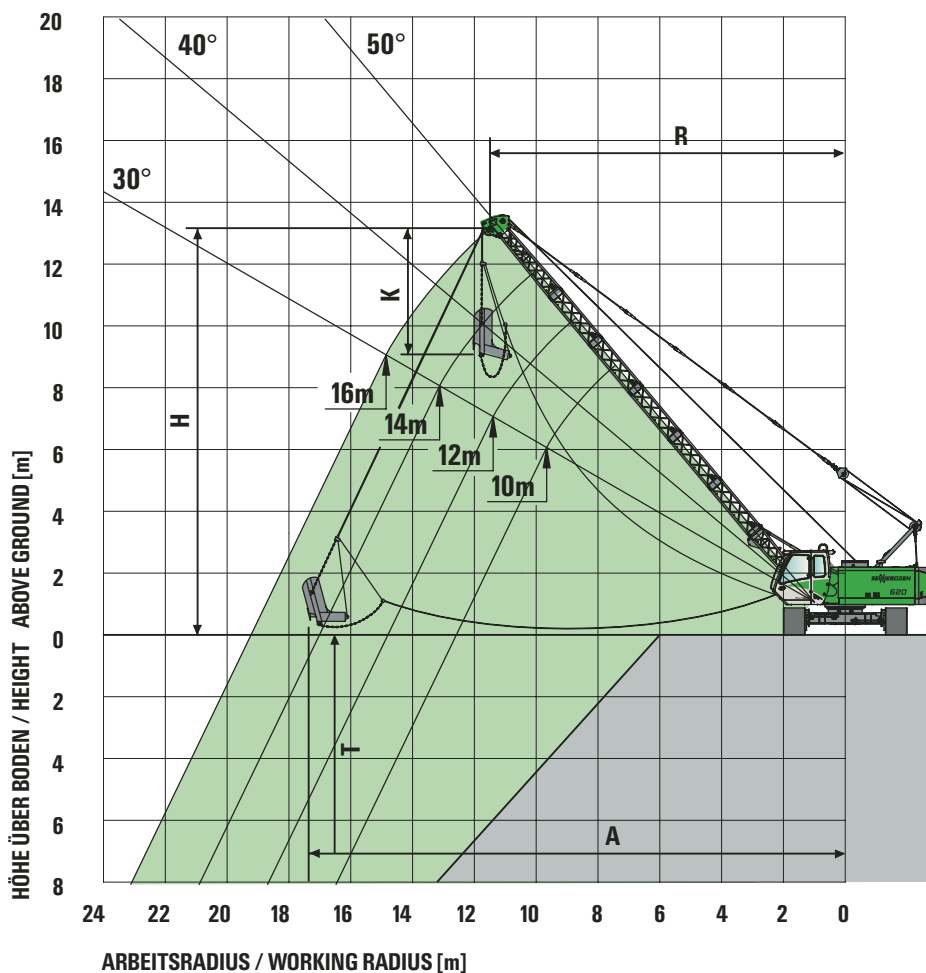

Anmerkungen:

1. Die angegebenen Traglasten beinhalten das Schleppschaufelgewicht und überschreiten nicht 75% der Kipplast.
2. Die Traglasten gelten bei max. Unterwagenspurbreite.
3. Die Schleppschaufelgröße ist entsprechend den gegebenen Bedingungen auszuliegen.

Grabkurve:

- R = Ausladung
- A = max. Grabweite = ca. $R + 1/3$ bis $1/2 (H-K)$
- T = Grabtiefe = ca. 40-50 % von R
- H = Höhe
- K = Länge der Schleppschaufel

Notes:

1. For dragline operation, bucket weight is considered part of the load and the total bucket weight plus contents must not exceed the corresponding ratings shown.
2. In operation, crawler must be extended.
3. The size of the bucket has to be determined according to local conditions.

Digging diagram:

- R = Radius
- A = max. digging reach = appr. $R + 1/3$ to $1/2 (H-K)$
- T = Digging depth = appr. 40-50 % of R
- H = Height
- K = Length of dragline

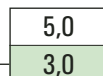
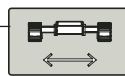

2,15 m

5,0
3,0

3,3 m

Auslegerlänge boom length	10,0 m			12,0 m			14,0 m			16,0 m		
Auslegerwinkel boom angle	R	H		R	H		R	H		R	H	
alpha [°]	m	m	t	m	m	t	m	m	t	m	m	t
50	7,7	8,6	5,0 3,0	8,9	10,1	4,0 2,4	10,2	11,7	3,3 1,9	11,5	13,2	2,7 1,6
45	8,3	8,0	4,5 2,7	9,7	9,4	3,6 2,1	11,1	10,8	2,9 1,7	12,5	12,2	2,4 1,4
40	8,9	7,3	4,1 2,5	10,4	8,6	3,2 1,9	11,9	9,9	2,6 1,5	13,4	11,2	2,1 1,2
35	9,4	6,6	3,8 2,3	11,0	7,8	3,0 1,8	12,6	8,9	2,4 1,4	14,3	10,1	1,9 1,1
30	9,8	5,9	3,5 2,1	11,5	6,9	2,8 1,6	13,3	7,9	2,2 1,3	15,0	8,9	1,8 1,0

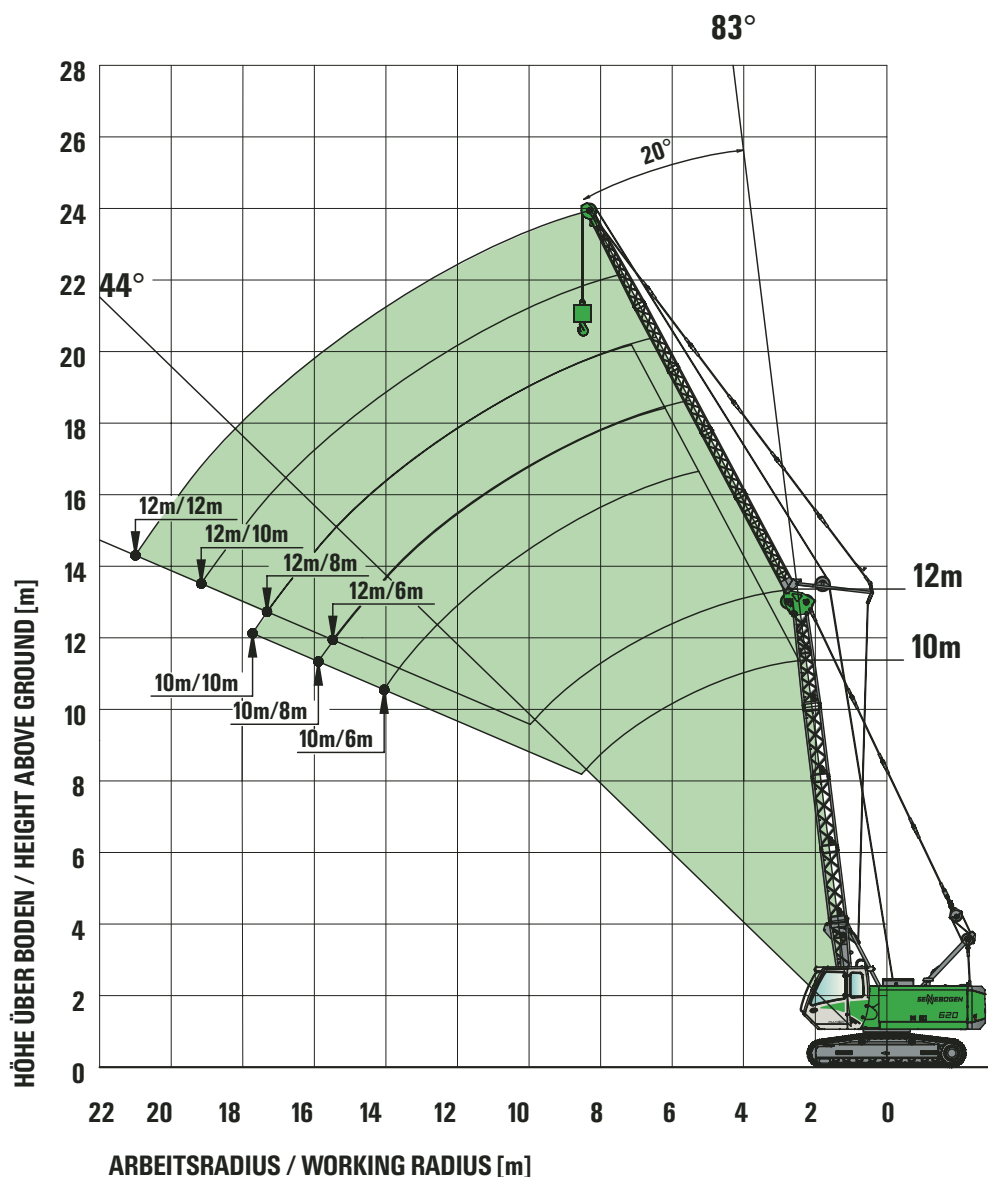
**SENEBOGEN®****620 HD****Spitzenausleger / Jib****D-Serie**

Auslegerkonfiguration - Hauptausleger mit Spitzenausleger boom configuration - main boom with jib								
Hauptausleger [m] main boom [m]		10			12			
Spitzenausleger [m] jib [m]		6	8	10	6	8	10	12
Fußstück lower boom	3 m	1	1	1	1	1	1	1
Zwischenstück boom insert	2 m	0	1	2	0	1	2	3
Kopfstück upper boom	3 m	1	1	1	1	1	1	1

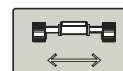
**SEINEBOGEN®****620 HD****Kran-Traglasten / crane load chart****Spitzenausleger
jib****3,3 m**

	Hauptauslegerlänge / main boom length [m]						
	10,0			12,0			
Ausladung	Spitzenauslegerlänge / fixed jib length [m]						
Radius[m]	6,0	8,0	10,0	6,0	8,0	10,0	12,0
5,0							
6,0	4,10			4,10			
7,0	4,10	3,65		4,10	3,65		
8,0	3,81	3,65	3,25	3,80	3,65	3,25	
9,0	3,51	3,39	3,25	3,50	3,38	3,25	3,06
10,0	3,22	3,13	3,03	3,19	3,12	3,02	3,06
11,0	2,92	2,88	2,80	2,89	2,85	2,79	2,83
12,0	2,63	2,62	2,58	2,59	2,59	2,56	2,60
13,0	2,33	2,36	2,36	2,29	2,32	2,33	2,37
14,0	2,06	2,11	2,14	2,02	2,06	2,10	2,14
15,0	1,83	1,87	1,91	1,78	1,82	1,86	1,91
16,0		1,67	1,70	1,58	1,62	1,66	1,70
17,0		1,49	1,52	1,41	1,44	1,48	1,51
18,0			1,36		1,29	1,32	1,35
19,0			1,22		1,15	1,18	1,21
20,0						1,05	1,08
21,0						0,93	0,96
22,0							0,85
23,0							0,75
24,0							
25,0							
26,0	TAB.-Nr. 620R-80/1703/3.8/02.10 SHFS 20						
Strangzahl / parts reeving	1	1	1	1	1	1	1

Anmerkungen:

- Die angegebenen Traglastwerte gelten für ebenen und festen Stand der Maschine.
- Traglastwerte sind in Tonnen angegeben und gelten für 360 Grad.
- Die Traglastwerte berücksichtigen die Normen DIN 15019/2 und ISO 4305 (Kippwinkel 4°)
- Das Gewicht der Lastaufnahmemittel (Haken, Gehänge) ist von den Traglasten abzuziehen.
- Die Traglastwerte gelten für maximale Unterwagenspurbreite.
- Lastwerte müssen begrenzt oder vermindert werden, um ungünstige Bedingungen zu berücksichtigen, wie weichen oder unebenen Boden, schräge Gefälle, Wind, Seitenlasten, schwingende Lasten, Rucken oder plötzliches Stoppen der Ladung, Unerfahrenheit des Personals, Fahren mit Last.
- Zulässiger Seilzug je Strang bei Kranbetrieb ist bei Seildurchmesser 16 mm - 4.500 kg
- Traglastwerte gelten für den SHFS-Ausleger (Zusammenbau gem. Anleitung)
- Traglastwerte gelten für optimalen Auslegerzusammenbau und Rollenkopf mit Kunststoffrollen.
- Die angegebenen Traglastwerte sind nur zur Orientierung. Die jeweils gültigen Traglastwerte entnehmen Sie bitte der Betriebsanleitung.

Alle Angaben vorläufig. Änderungen vorbehalten.

Notes:

- The rated loads shown are based on the machine on firm level ground and without travelling.
- The rated loads shown are in metric tons valid for 360 degrees swing.
- Liftcrane capacities are calculated to comply with DIN 15019/2 and ISO 4305 (tipping angle 4 deg.)
- The rated loads shown include the weight of all lifting attachments, such as hook and bucket.
- In operation crawler must be extended.
- The users must derate or limit the lifted loads to allow for adverse conditions such as soft or uneven ground, out of level conditions, wind side loads, pendulum action, jerking or sudden stopping of loads, inexperience of personnel and travelling with a load.
- Max. single line pull for crane operation with rope diameter 16 mm - 4.500 kg
- Loads are valid for SHFS-boom (boom assembly acc. operation manual)
- Lifting chart values apply to optimum boom assembly and boom head with plastic sheaves.
- The lifting capacities above are for reference only. For actual lifting capacities please refer to load chart in operator's manual.

All informations are subject to be changed without prior notice.

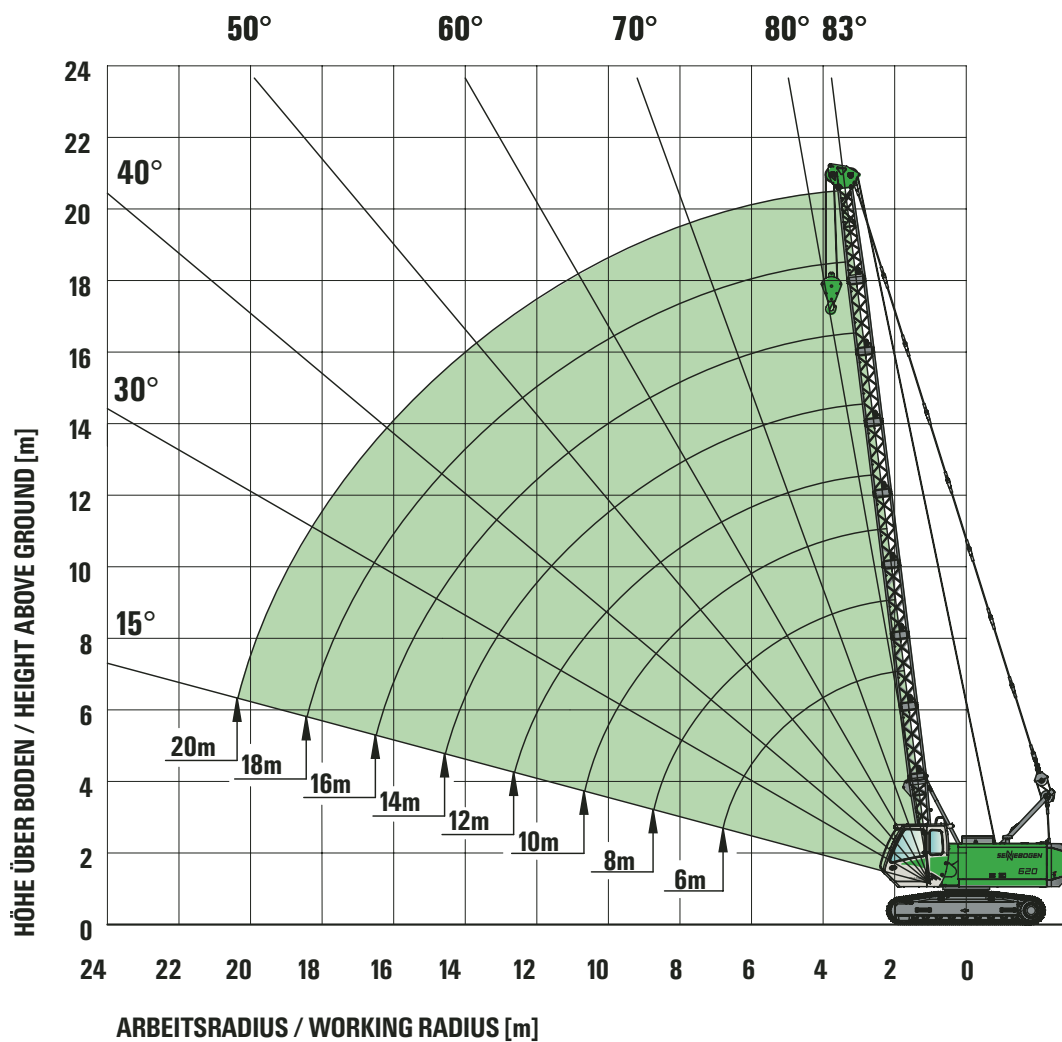



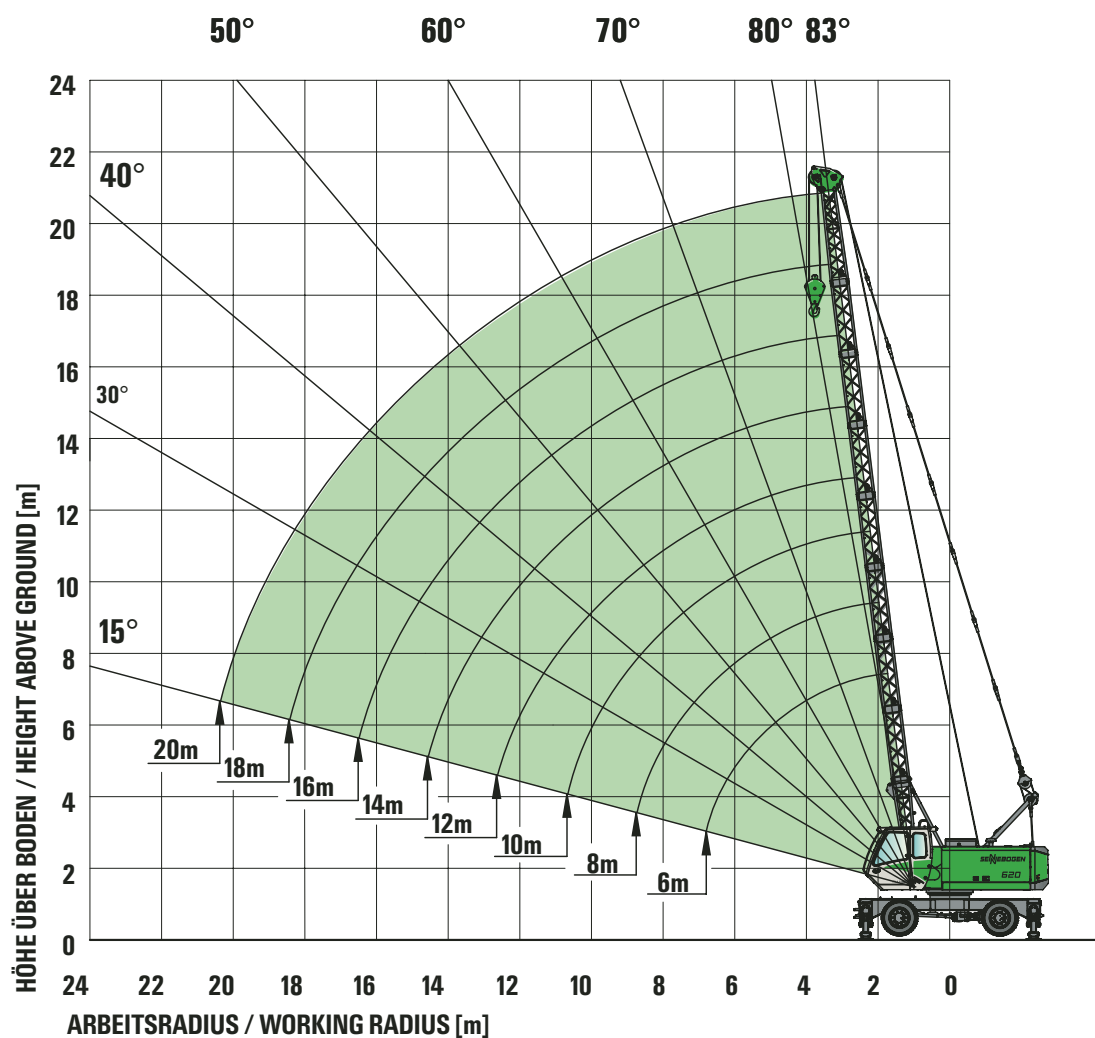

**SENEBOGEN[®]****620 HD****Kranausrüstung / Crane Equipment****D-Serie**

Auslegerkonfiguration - Hauptausleger boom configuration - main boom		8	10	12	14	16	18	20
Auslegerlänge[m] boom length [m]								
Fußstück 660.52 lower boom	3 m	1	1	1	1	1	1	1
Zwischenstück 660.52 boom insert	2 m	1	2	3	4	5	6	7
Kopfstück 660.52 upper boom	3 m	1	1	1	1	1	1	1







**SENEBOGEN[®]****620 M****Kranausrüstung / Crane Equipment****D-Serie**

Auslegerkonfiguration - Hauptausleger hydraulisch klappbar boom configuration - main boom hydraulically foldable			
Auslegerlänge[m] boom length [m]		10	12
Fußstück klappbar mit Zylinder 660.52 lower boom foldable with cylinder	3 m	1	1
Klappstück 660.52 folding boom insert	2 m	1	1
Zwischenstück 660.52 boom insert	2 m	1	2
Kopfstück 660.52 upper boom	3 m	1	1

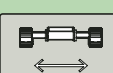
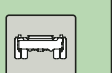
**SEINEBOGEN®****620 HD****Kran-Traglasten / crane load chart**

		620 HD			620 M		620 HD			
Auslegerlänge boom length	Ausladung Radius						Auslegerlänge boom length	Ausladung Radius		
		2,15 m	2,03 m	3,3 m					2,15 m	2,03 m
[m]	[m]	[t]	[t]	[t]	[t]	[t]	[m]	[m]	[t]	[t]
6	2,0	20,0	20,0	20,0	13,0	20,0	14	3,0	11,0	10,7
	2,5	16,6	16,6	18,5	11,6	18,6		3,5	9,6	9,2
	3,0	12,9	13,0	16,8	10,2	17,1		4,0	8,1	8,0
	3,5	10,1	10,2	15,2	8,7	15,7		5,0	5,9	6,0
	4,0	8,3	8,4	13,6	7,3	14,2		6,0	4,5	4,6
	5,0	6,0	6,1	10,3	5,3	11,2		7,0	3,6	3,7
	6,0	4,7	4,8	7,8	4,1	8,3		8,0	3,0	3,1
8	2,5	14,9	14,9	15,5	10,5	15,5		9,0	2,6	2,6
	3,0	12,5	12,6	14,4	9,4	14,5		10,0	2,2	2,3
	3,5	10,1	10,2	13,3	8,3	13,5		11,0	1,9	2,0
	4,0	8,2	8,4	12,2	7,2	12,4		12,0	1,7	1,7
	5,0	6,0	6,1	10,0	5,3	10,4		13,0	1,5	1,5
	6,0	4,7	4,8	7,8	4,1	8,3		14,0	1,3	1,4
	7,0	3,8	3,9	6,2	3,3	6,6		16	3,5	9,4
8,0	3,2	3,2	5,1	2,8	5,4	4,0	8,1		7,7	
10	2,5	13,0	13,0	13,0	8,1	13,0	5,0		5,8	5,9
	3,0	11,5	11,5	12,3	7,6	12,3	6,0		4,5	4,6
	3,5	9,8	9,9	11,5	7,0	11,6	7,0		3,6	3,7
	4,0	8,2	8,3	10,7	6,4	10,9	8,0		3,0	3,1
	5,0	6,0	6,1	9,2	5,2	9,4	9,0		2,5	2,6
	6,0	4,6	4,7	7,7	4,1	8,0	10,0		2,1	2,2
	7,0	3,7	3,8	6,1	3,3	6,5	11,0		1,9	1,9
	8,0	3,1	3,2	5,1	2,8	5,4	12,0		1,6	1,7
	9,0	2,7	2,7	4,3	2,4	4,5	13,0	1,4	1,5	
	10,0	2,3	2,4	3,8	2,0	3,9	14,0	1,3	1,3	
12	3,0	11,3	11,3	11,7	7,6	11,7	15,0	1,1	1,2	
	3,5	9,7	9,8	11,0	7,0	11,1	16,0	1,0	1,1	
	4,0	8,2	8,3	10,2	6,4	10,4	Anmerkungen: 1. Die angegebenen Traglastwerte gelten für ebenen und festen Stand der Maschine. 2. Traglastwerte sind in Tonnen angeben und gelten für 360 Grad. 3. Die Traglastwerte berücksichtigen die Normen DIN 15019/2 und ISO 4305 (Kippwinkel 4°) 4. Das Gewicht der Lastaufnahmemittel (Haken, Gehänge) ist von den Traglasten abzuziehen. 5. Lastwerte müssen begrenzt oder vermindert werden, um ungünstige Bedingungen zu berücksichtigen, wie weichen oder unebenen Boden, schräge Gefälle, Wind, Seitenlasten, schwingende Lasten, Rucken oder plötzliches Stoppen der Ladung, Unerfahrenheit des Personals, Fahren mit Last. 6. Zulässiger Seilzug je Strang bei Kranbetrieb ist bei Seildurchmesser 16 mm - 4.500 kg 7. Traglastwerte gelten für den SH-Ausleger (Zusammenbau gem. Anleitung) 8. Traglastwerte gelten für optimalen Auslegerzusammenbau und Rollenkopf mit Kunststoffrollen. 9. Die angegebenen Traglastwerte sind nur zur Orientierung. Die jeweils gültigen Traglastwerte entnehmen Sie bitte der Betriebsanleitung. Alle Angaben vorläufig, Änderungen vorbehalten.			
	5,0	5,9	6,0	8,9	5,2	9,1				
	6,0	4,6	4,7	7,5	4,0	7,8				
	7,0	3,7	3,8	6,1	3,3	6,5				
	8,0	3,1	3,2	5,1	2,7	5,3				
	9,0	2,6	2,7	4,3	2,3	4,5				
	10,0	2,2	2,3	3,7	2,0	3,9				
	11,0	2,0	2,0	3,2	1,7	3,4				
	12,0	1,7	1,8	2,9	1,5	3,0				

**SENEBOGEN®****620 HD**

620 _M			620 _{HD}				620 _M		
			Auslegerlänge boom length	Ausladung Radius					
3,3 m			[m]	[m]	2,15 m	2,03 m	3,3 m		
[t]	[t]	[t]			[t]	[t]	[t]	[t]	[t]
11,0	6,7	11,0	18	3,5	8,5	8,4	8,5	5,0	8,5
10,4	6,2	10,4		4,0	7,6	7,3	8,1	4,7	8,1
9,8	5,8	9,9		5,0	5,8	5,8	7,3	4,2	7,4
8,6	4,9	8,7		6,0	4,4	4,6	6,5	3,7	6,6
7,3	4,0	7,6		7,0	3,6	3,7	5,7	3,1	5,9
6,1	3,2	6,4		8,0	2,9	3,0	4,9	2,6	5,1
5,0	2,7	5,3		9,0	2,5	2,5	4,2	2,2	4,4
4,2	2,3	4,5		10,0	2,1	2,2	3,6	1,9	3,7
3,7	1,9	3,8		11,0	1,8	1,9	3,1	1,6	3,2
3,2	1,7	3,3		12,0	1,6	1,6	2,7	1,4	2,9
2,8	1,5	2,9		13,0	1,4	1,4	2,4	1,2	2,5
2,5	1,3	2,6		14,0	1,2	1,3	2,2	1,1	2,3
2,3	1,2	2,4		15,0	1,1	1,1	2,0	0,9	2,0
9,8	5,5	9,8		16,0	1,0	1,0	1,8	0,8	1,8
9,2	5,1	9,3	17,0	0,9	0,9	1,6	0,7	1,7	
8,2	4,5	8,3	18,0	0,8	0,8	1,5	0,7	1,5	
20	7,1	3,8	4,0	7,1	7,1	7,3	4,4	7,4	
	6,0	3,2	5,0	5,7	5,6	6,7	3,9	6,7	
	5,0	2,6	6,0	4,4	4,5	6,1	3,5	6,1	
	4,2	2,2	7,0	3,5	3,6	5,4	3,0	5,5	
	3,6	1,9	8,0	2,9	3,0	4,8	2,5	4,9	
	3,1	1,6	9,0	2,4	2,5	4,1	2,1	4,3	
	2,8	1,4	10,0	2,1	2,1	3,5	1,8	3,7	
	2,5	1,3	11,0	1,8	1,8	3,1	1,5	3,2	
	2,2	1,1	12,0	1,5	1,6	2,7	1,3	2,8	
	2,0	1,0	13,0	1,3	1,4	2,4	1,2	2,5	
	1,8	0,9	14,0	1,2	1,2	2,1	1,0	2,2	
			15,0	1,0	1,1	1,9	0,9	2,0	
			16,0	0,9	1,0	1,7	0,8	1,8	
			17,0	0,8	0,9	1,6	0,7	1,6	
		18,0	0,7	0,8	1,4	0,6	1,5		
		19,0	0,6	0,7	1,3	0,5	1,3		
		20,0	0,6	0,6	1,2	0,5	1,2		

Notes:

- The rated loads shown are based on the machine on firm level ground and without travelling.
- The rated loads shown are in metric tons valid for 360 degrees swing.
- Liftcrane capacities are calculated to comply with DIN 15019/2 and ISO 4305 (tipping angle 4 deg.)
- The rated loads shown include the weight of all lifting attachments, such as hook and bucket.
- The users must derate or limit the lifted loads to allow for adverse conditions such as soft or uneven ground, out of level conditions, wind side loads, pendulum action, jerking or sudden stopping of loads, nexperience of personnel and travelling with a load.
- Max. single line pull for crane operation with rope diameter 16 mm - 4.500 kg
- Loads are valid for SH-boom (boom assembly acc. operation manual)
- Lifting chart values apply to optimum boom assembly and boom head with plastic sheaves.
- The lifting capacities above are for reference only. For actual lifting capacities please refer to load chart in operator's manual.

All informations are subject to be changed without prior notice.

**SENEBOGEN**[®]**620 M**

Spitzenausleger / Jib

D-Serie

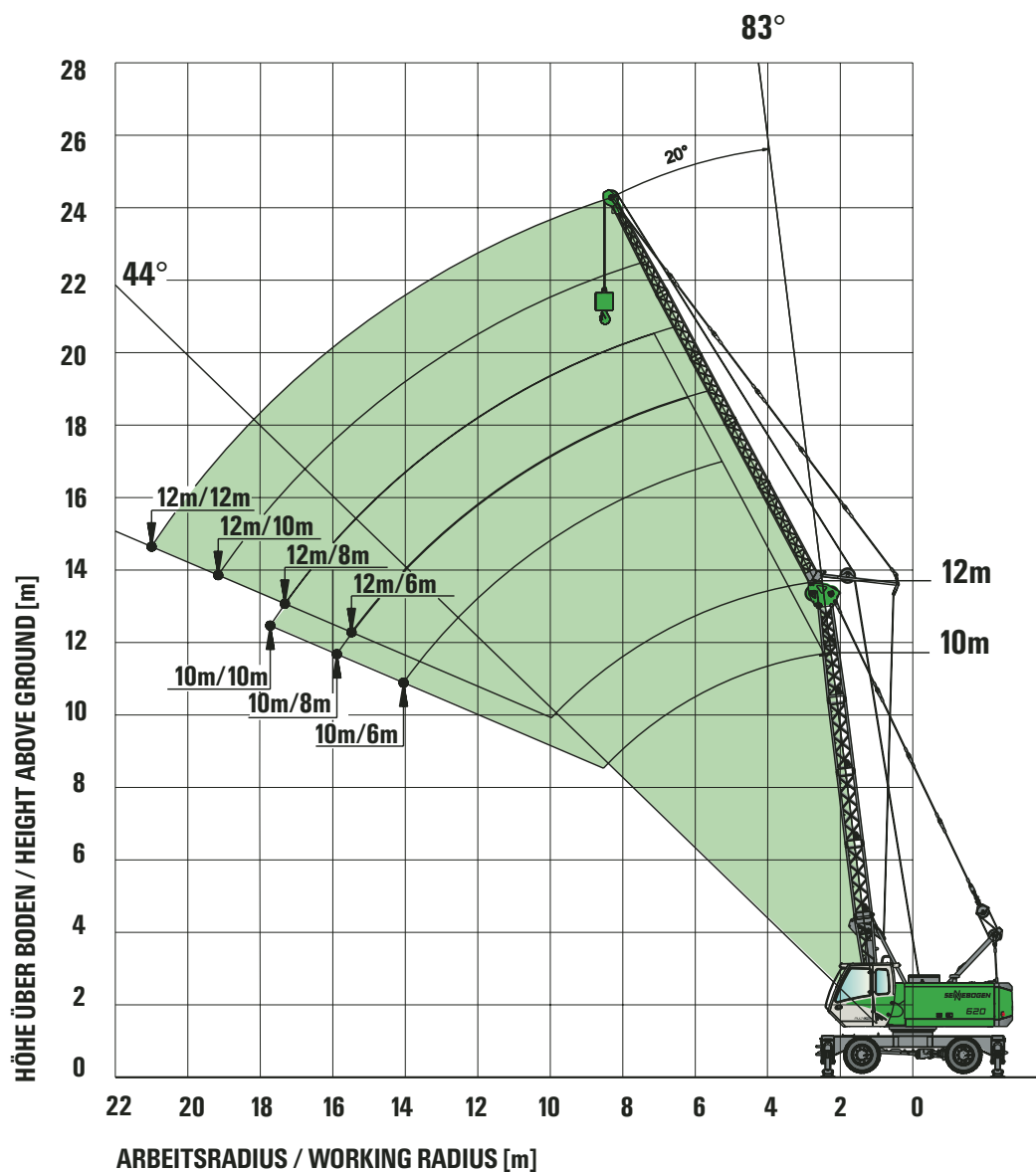

Auslegerkonfiguration - Hauptausleger mit Spitzenausleger boom configuration - main boom with jib								
Hauptausleger [m] main boom [m]		10			12			
Spitzenausleger [m] jib [m]		6	8	10	6	8	10	12
Fußstück lower boom	3 m	1	1	1	1	1	1	1
Zwischenstück boom insert	2 m	0	1	2	0	1	2	3
Kopfstück upper boom	3 m	1	1	1	1	1	1	1

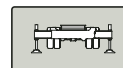
**SENEBOGEN[®]****620 M****Kran-Traglasten / crane load chart****Spitzenausleger
jib**

	Hauptauslegerlänge / main boom length [m]						
	10,0			12,0			
Ausladung	Spitzenauslegerlänge / fixed jib length [m]						
Radius[m]	6,0	8,0	10,0	6,0	8,0	10,0	12,0
5,0							
6,0	4,10			4,10			
7,0	4,10	3,65		4,10	3,65		
8,0	3,81	3,65	3,25	3,80	3,65	3,25	
9,0	3,51	3,39	3,25	3,50	3,38	3,25	3,06
10,0	3,22	3,13	3,03	3,19	3,12	3,02	3,06
11,0	2,92	2,88	2,80	2,89	2,85	2,79	2,83
12,0	2,63	2,62	2,58	2,59	2,59	2,56	2,60
13,0	2,33	2,36	2,36	2,29	2,32	2,33	2,37
14,0	2,06	2,11	2,14	2,02	2,06	2,10	2,14
15,0	1,83	1,87	1,91	1,78	1,82	1,86	1,91
16,0		1,67	1,70	1,58	1,62	1,66	1,70
17,0		1,49	1,52	1,41	1,44	1,48	1,51
18,0			1,36		1,29	1,32	1,35
19,0			1,22		1,15	1,18	1,21
20,0						1,05	1,08
21,0						0,93	0,96
22,0							0,85
23,0							0,75
24,0							
25,0							
26,0	TAB.-Nr. 620R-80/1703/3.8/02.10 SHFS 20						
Strangzahl / parts reeving	1	1	1	1	1	1	1

Anmerkungen:

- Die angegebenen Traglastwerte gelten für ebenen und festen Stand der Maschine.
- Traglastwerte sind in Tonnen angegeben und gelten für 360 Grad.
- Die Traglastwerte berücksichtigen die Normen DIN 15019/2 und ISO 4305 (Kippwinkel 4°)
- Das Gewicht der Lastaufnahmemittel (Haken, Gehänge) ist von den Traglasten abzuziehen.
- Die Traglastwerte gelten für maximale Unterwagenspurbreite.
- Lastwerte müssen begrenzt oder vermindert werden, um ungünstige Bedingungen zu berücksichtigen, wie weichen oder unebenen Boden, schräge Gefälle, Wind, Seitenlasten, schwingende Lasten, Rucken oder plötzliches Stoppen der Ladung, Unerfahrenheit des Personals, Fahren mit Last.
- Zulässiger Seilzug je Strang bei Kranbetrieb ist bei Seildurchmesser 16 mm - 4.500 kg
- Traglastwerte gelten für den SHFS-Ausleger (Zusammenbau gem. Anleitung)
- Traglastwerte gelten für optimalen Auslegerzusammenbau und Rollenkopf mit Kunststoffrollen.
- Die angegebenen Traglastwerte sind nur zur Orientierung. Die jeweils gültigen Traglastwerte entnehmen Sie bitte der Betriebsanleitung.

Alle Angaben vorläufig. Änderungen vorbehalten.

Notes:

- The rated loads shown are based on the machine on firm level ground and without travelling.
- The rated loads shown are in metric tons valid for 360 degrees swing.
- Liftcrane capacities are calculated to comply with DIN 15019/2 and ISO 4305 (tipping angle 4 deg.)
- The rated loads shown include the weight of all lifting attachments, such as hook and bucket.
- In operation crawler must be extended.
- The users must derate or limit the lifted loads to allow for adverse conditions such as soft or uneven ground, out of level conditions, wind side loads, pendulum action, jerking or sudden stopping of loads, inexperience of personnel and travelling with a load.
- Max. single line pull for crane operation with rope diameter 16 mm - 4.500 kg
- Loads are valid for SHFS-boom (boom assembly acc. operation manual)
- Lifting chart values apply to optimum boom assembly and boom head with plastic sheaves.
- The lifting capacities above are for reference only. For actual lifting capacities please refer to load chart in operator's manual.

All informations are subject to be changed without prior notice.

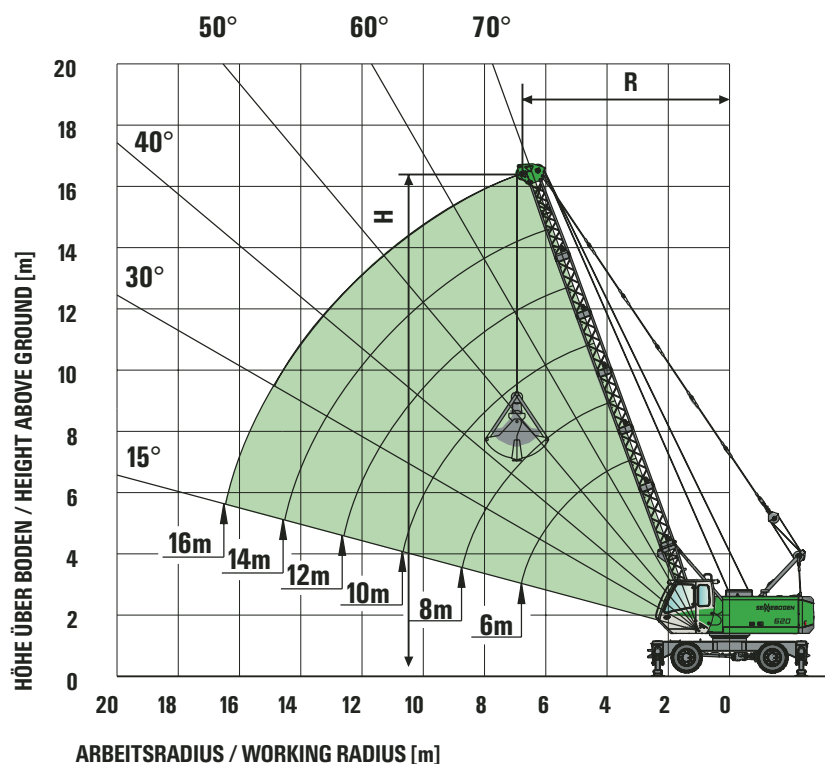
**SENEBOGEN**[®]**620 M****Greiferausrüstung / Clamshell Equipment****D-Serie****Anmerkungen:**

- Die angegebenen Traglasten beinhalten das Greifergewicht und überschreiten nicht 66,7 % der Kipplast.
- Die Traglasten gelten bei max. Unterwagensebreite.

Arbeitsbereich:

- R = Ausladung
H = Höhe
K = Länge des Greifers

Notes:

- For clamshell operations, bucket weight is considered part of the load and the total bucket weight plus contents must not exceed the corresponding ratings shown.
- In operation, crawlers must be extended.

Working range:

- R = Radius
H = Height
K = Length of grab

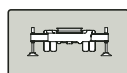

Auslegerlänge boom length	10,0 m			12,0 m			14,0 m			16,0 m		
	R	H		R	H		R	H		R	H	
Auslegerwinkel boom angle	m	m	t	m	m	t	m	m	t	m	m	t
alpha [°]												
70	4,7	10,4	9,4	5,4	12,3	7,5	6,1	14,2	6,2	6,8	16,1	5,3
65	5,5	10,1	7,3	6,3	11,9	5,9	7,2	13,7	4,8	8,0	15,5	4,1
60	6,3	9,7	6,0	7,3	11,4	4,8	8,3	13,1	3,9	9,3	14,8	3,3
55	7,0	9,2	5,1	8,1	10,8	4,1	9,3	12,4	3,3	10,4	14,1	2,8
50	7,7	8,6	4,5	8,9	10,1	3,5	10,2	11,7	2,9	11,5	13,2	2,4
45	8,3	8,0	4,0	9,7	9,4	3,2	11,1	10,8	2,6	12,5	12,2	2,1
40	8,9	7,3	3,6	10,4	8,6	2,9	11,9	9,9	2,3	13,4	11,2	1,9
35	9,4	6,6	3,4	11,0	7,8	2,6	12,6	8,9	2,1	14,3	10,1	1,7
30	9,8	5,9	3,1	11,5	6,9	2,5	13,3	7,9	2,0	15,0	8,9	1,6
25	10,2	5,1	3,0	12,0	5,9	2,3	13,8	6,8	1,9	15,6	7,6	1,5
20	10,5	4,3	2,9	12,4	5,0	2,2	14,3	5,6	1,8	16,1	6,3	1,4
15	10,7	3,4	2,8	12,7	4,0	2,1	14,6	4,5	1,7	16,5	5,0	1,4



Schleppschaufel­aus­rüs­tung / Dragline Equipment

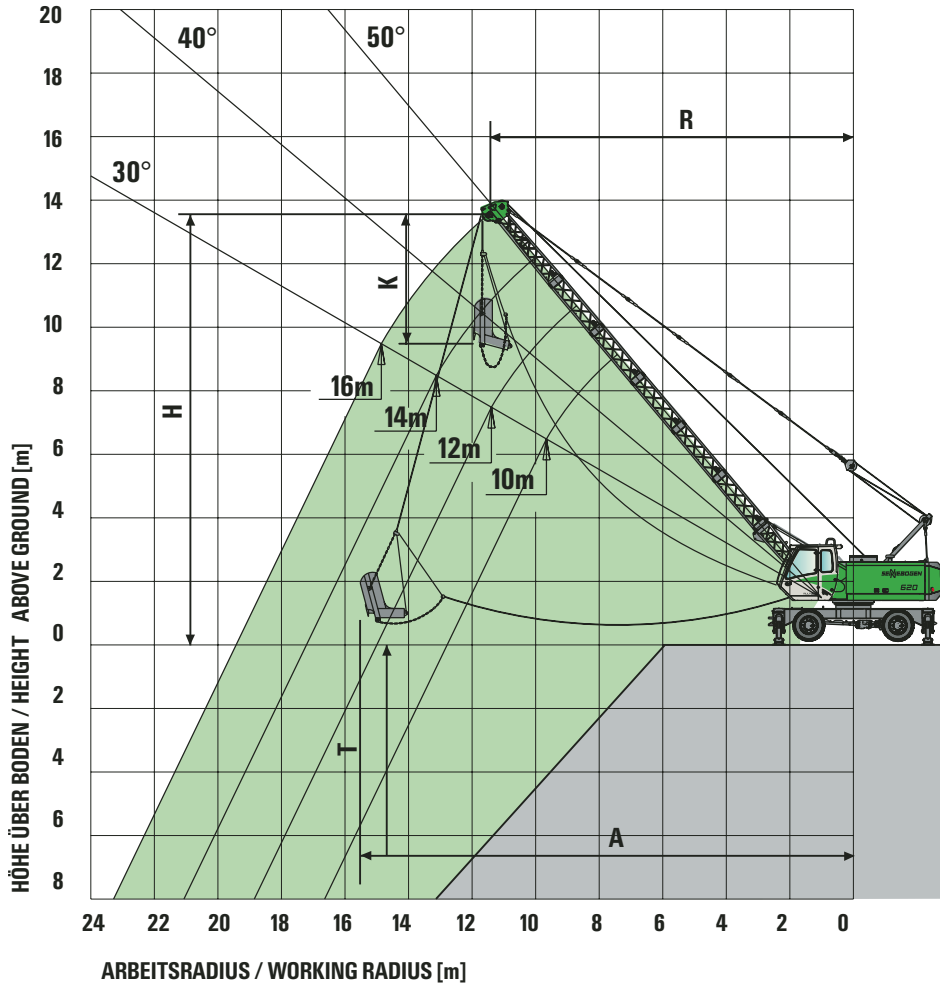

Anmerkungen:

1. Die angegebenen Traglasten beinhalten das Schleppschaufelgewicht und überschreiten nicht 75% der Kipplast.
2. Die Traglasten gelten bei max. Unterwagenspurbreite.
3. Die Schleppschaufelgröße ist entsprechend den gegebenen Bedingungen auszulegen.

Grabkurve:

- R = Ausladung
- A = max. Grabweite = ca. $R + 1/3$ bis $1/2 (H-K)$
- T = Grabtiefe = ca. 40-50 % von R
- H = Höhe
- K = Länge der Schleppschaufel

Notes:

1. For dragline operation, bucket weight is considered part of the load and the total bucket weight plus contents must not exceed the corresponding ratings shown.
2. In operation, crawler must be extended.
3. The size of the bucket has to be determined according to local conditions.

Digging diagram:

- R = Radius
- A = max. digging reach = appr. $R + 1/3$ to $1/2 (H-K)$
- T = Digging depth = appr. 40-50 % of R
- H = Height
- K = Length of dragline

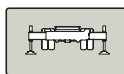

Auslegerlänge boom length	10,0 m			12,0 m			14,0 m			16,0 m		
Auslegerwinkel boom angle	R	H		R	H		R	H		R	H	
alpha [°]	m	m	t	m	m	t	m	m	t	m	m	t
50	7,7	8,6	5,0	8,9	10,1	4,0	10,2	11,7	3,3	11,5	13,2	2,7
45	8,3	8,0	4,5	9,7	9,4	3,6	11,1	10,8	2,9	12,5	12,2	2,4
40	8,9	7,3	4,1	10,4	8,6	3,2	11,9	9,9	2,6	13,4	11,2	2,1
35	9,4	6,6	3,8	11,0	7,8	3,0	12,6	8,9	2,4	14,3	10,1	1,9
30	9,8	5,9	3,5	11,5	6,9	2,8	13,3	7,9	2,2	15,0	8,9	1,8



SENNEBOGEN®

620 M

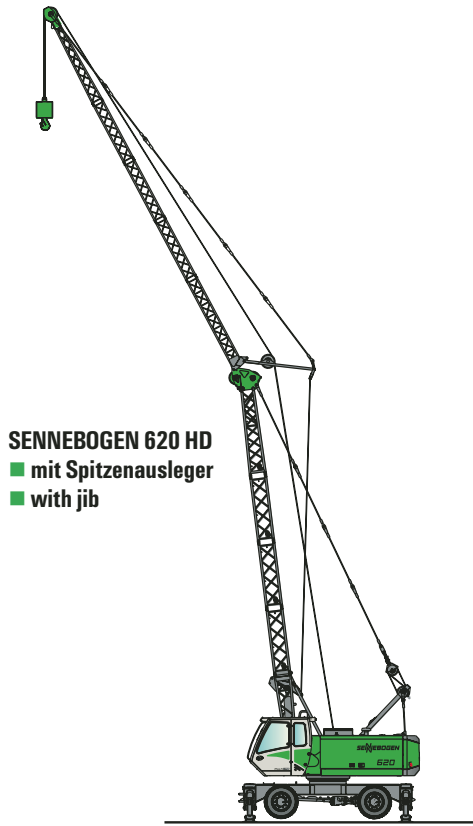

SENNEBOGEN 620 HD
■ mit Spitzenausleger
■ with jib



SENNEBOGEN 620 HD
■ mit Schleppschaufel­ausrüstung
■ with dragline attachment

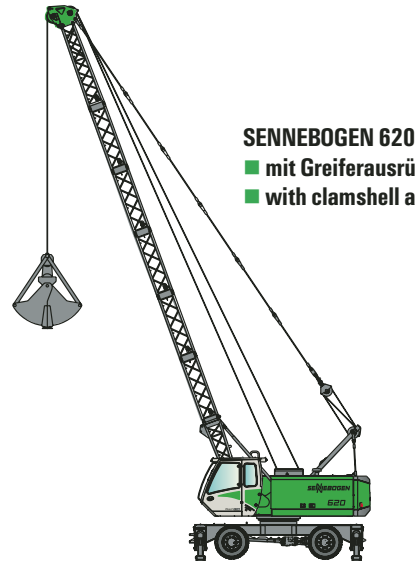

SENNEBOGEN 620 HD
■ mit Greiferausrüstung
■ with clamshell attachment

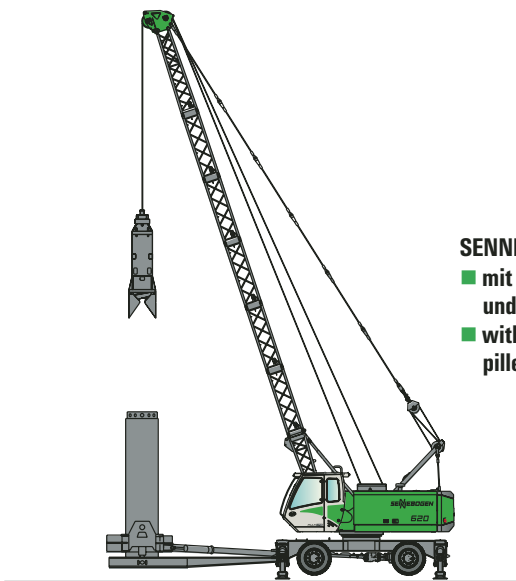

SENNEBOGEN 620 HD
■ mit Verrohrungs­maschine
und Bohrgreifer
■ with casing oscillator and
pilegrab

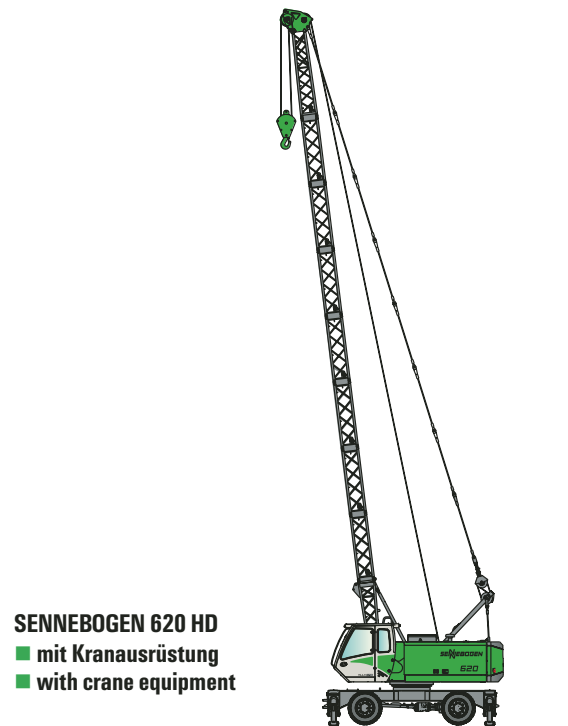

SENNEBOGEN 620 HD
■ mit Kranausrüstung
■ with crane equipment

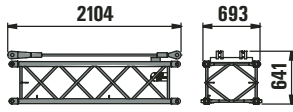
**SENEBOGEN**[®]**620 M****Transportmaße / Transport dimensions**

Auslegerzwischenstück 2m Typ 660.52 (mit Abspannung)
boom insert 2m type 660.52 (with pendants)
Gewicht: 133 kg
weight: 133 kg

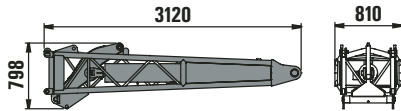

Klappauslegerfußstück 3m Typ 660.52
Lower boom section 3m type 660.52
Gewicht: 636kg
weight: 636kg

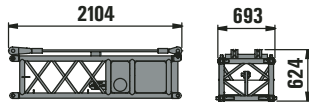

Klappauslegerzwischenstück 2m Typ 660.52 (mit Abspannung)
boom insert 2m type 660.52 (with pendants)
Gewicht: 245 kg
weight: 245 kg

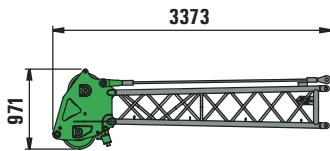

Auslegerkopfstück 3m Typ 660.52 (mit Abspannung)
Upper boom 3m type 660.52 with pendants
Gewicht: 335 kg (mit Kunststoffrollen)
weight: 335 kg (with synthetik sheaves)
Breite: 693mm
width: 693mm

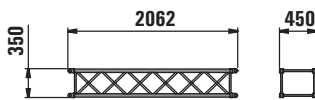

Spitzenausleger Zwischenstück 2m
jib insert 2m
Gewicht: 56 kg
weight: 56 kg

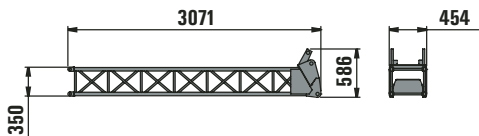

Spitzenausleger Fußstück 3m
jib lower boom section 3m
Gewicht: 200 kg
weight: 200 kg

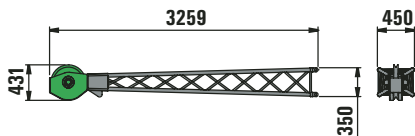

Spitzenausleger Kopfstück 3m
jib upper boom 3m
Gewicht: 134 kg (mit Kunststoffrollen)
weight: 134 kg (with synthetik sheaves)



Haken für 60 KN Winde mit 16 mm Seildurchmesser
Hook for 60 KN winch with 16 mm rope diameter

Kapazität capacity	Gewicht weight	Seilstränge und max. Traglast / Noof reevings and max rated load				
		5	4	3	2	1
5 t						4.500 kg
14 t 1 Rolle				13.500 kg	9.000 kg	4.500 kg
20 t 2 Rollen		20.000 kg	18.000 kg	13.500 kg	9.000 kg	4.500 kg



SENEBOGEN®

620 HD

Maße / Dimensions

620 HD Raupe mit Starrunterwagen R25

620 HD Crawler with fixed undercarriage 25

ca. / appr. 21.500 kg

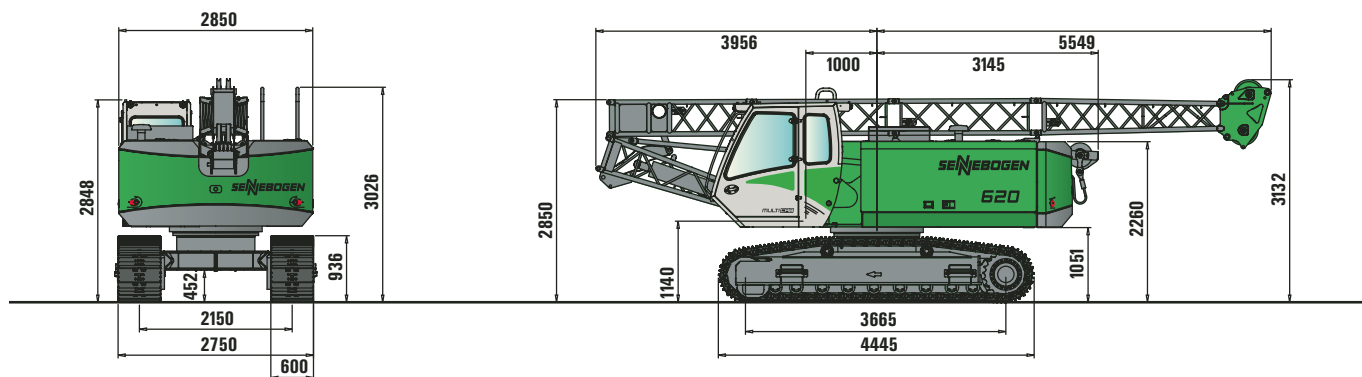

620 HD Raupe mit teleskopierbarem Unterwagen T17-330

620 HD Crawler with extendable undercarriage T17-330

ca. / appr. 23.500 kg

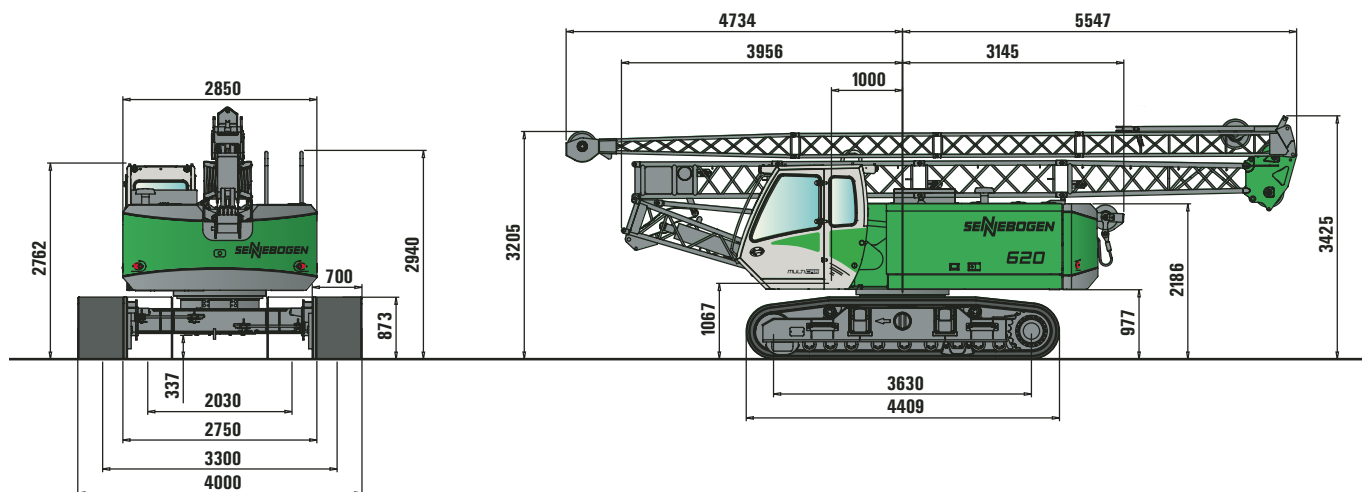
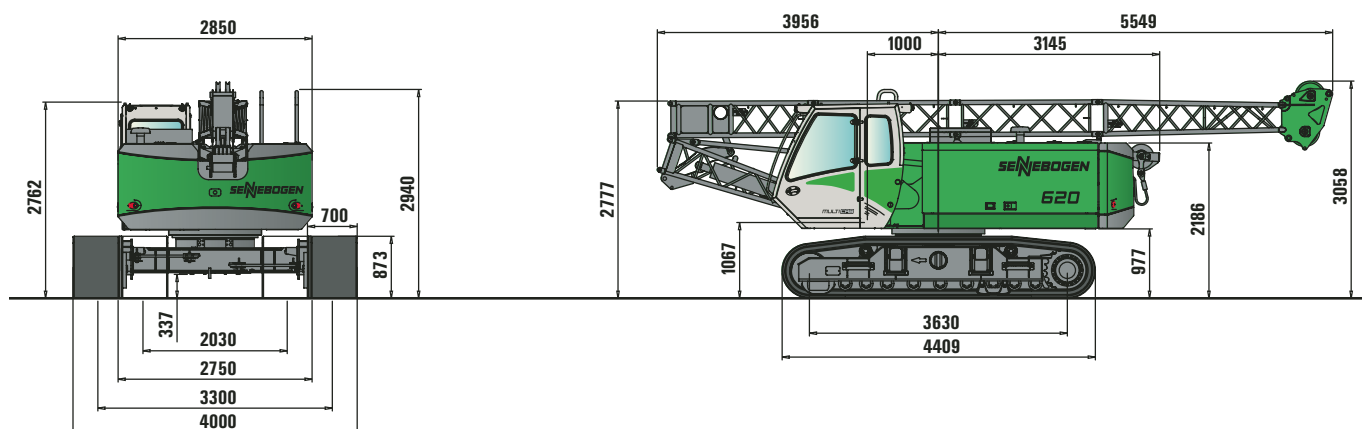



SENEBOGEN®

620 M

Maße / Dimensions

620 M mit Mobilunterwagen MP26

620 M with rubber tired undercarriage MP26

ca. / appr. 22.500 kg

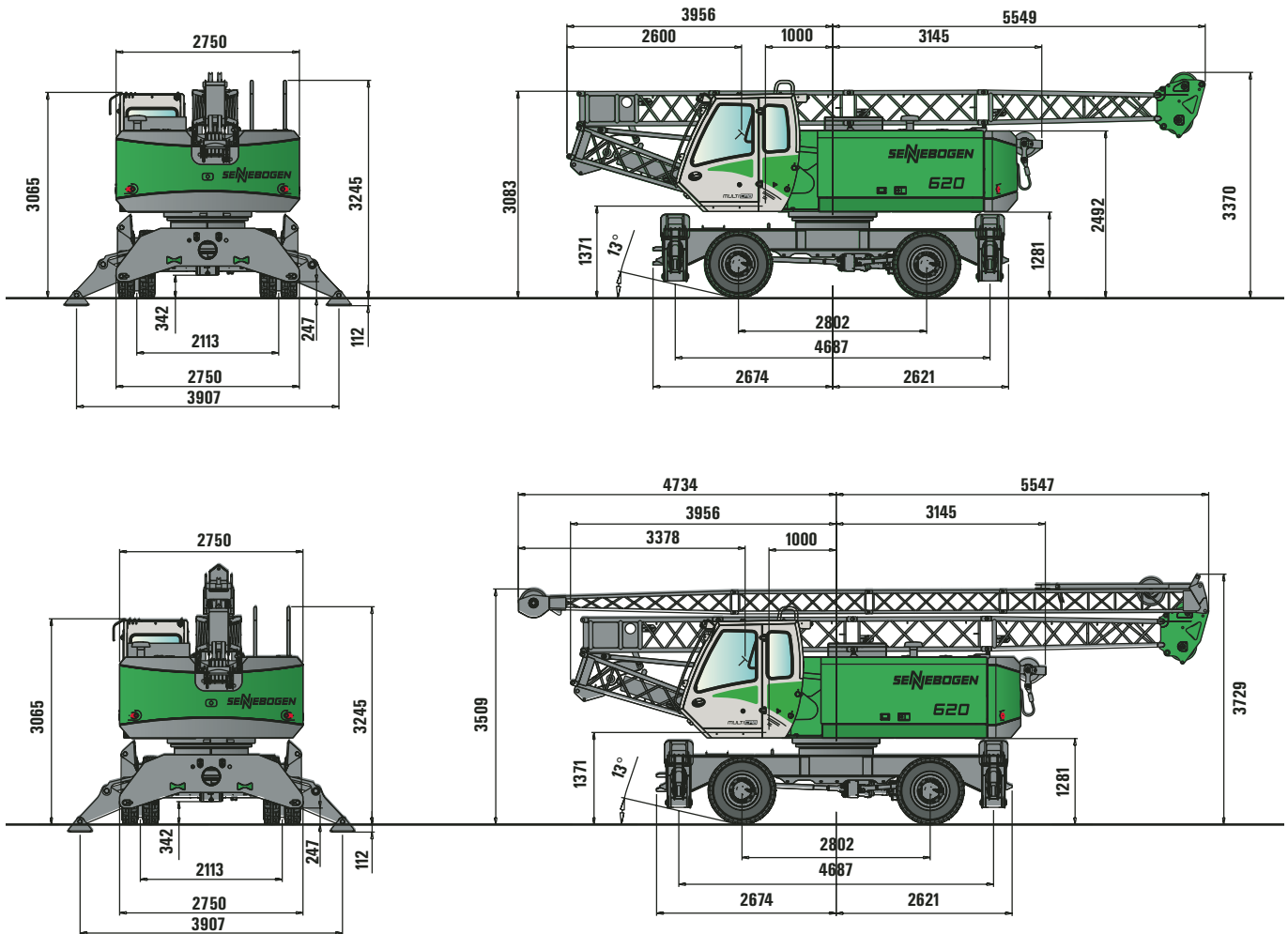



620 HD

Maße / Dimensions

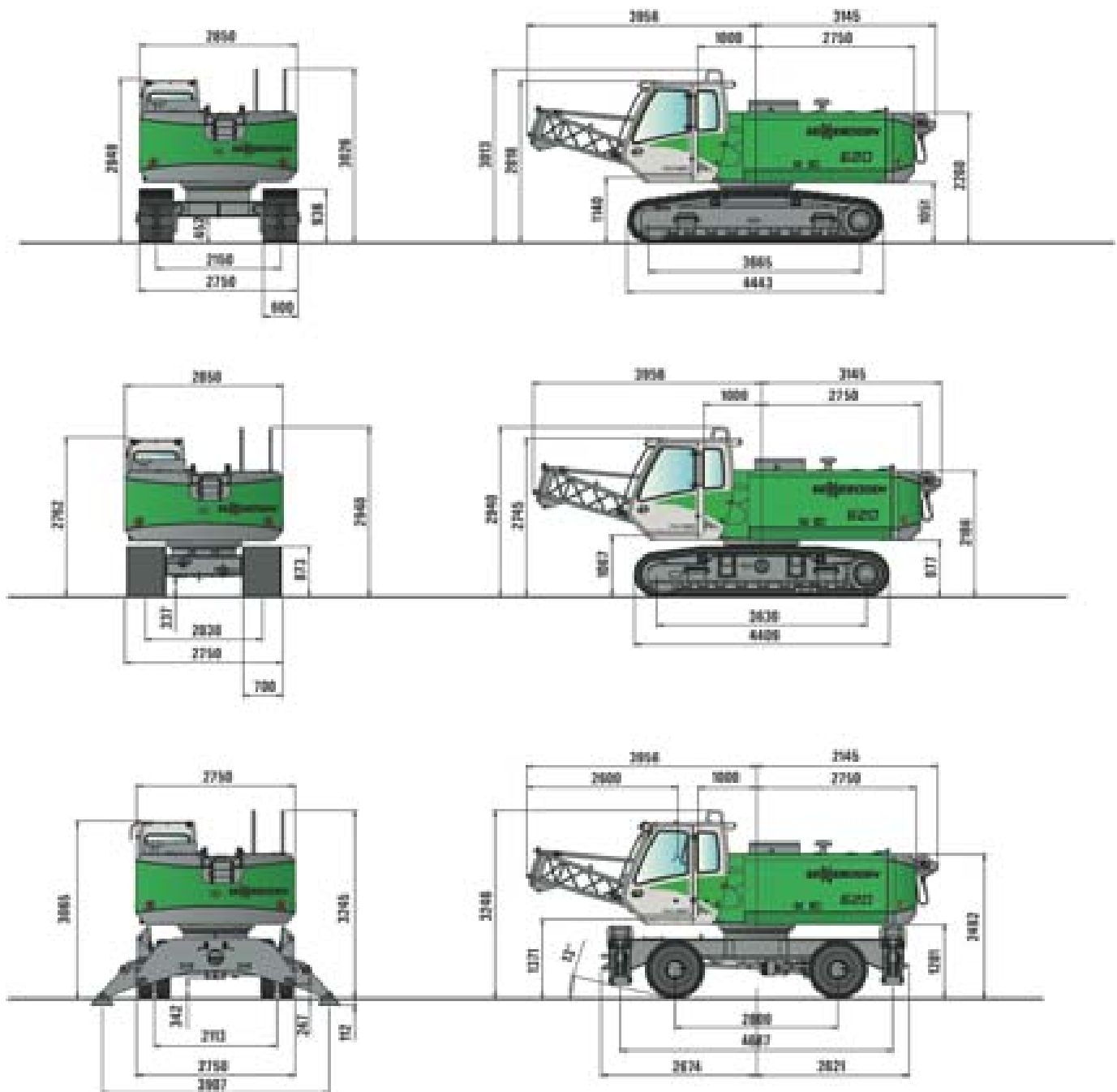

SENNEBOGEN
Maschinenfabrik GmbH
 Sennebogenstraße 10
 94315 Straubing, Germany

Tel. +49 9421 540-144/146
 Fax +49 9421 43 882
 marketing@sennebogen.de

620 HD - 041025*