



# P&H<sup>®</sup> OMEGA<sup>®</sup> T-250

**25-ton hydraulic truck crane**  
**134-ft. (40.8m) maximum tip height**



PROVEN OMEGA<sup>®</sup> UPPER WITH NEW TRUCK CARRIER

- **Excellent reach** afforded by telescoping 80 ft. (24.4 m) 3 section full power boom. Add 30 ft. (9.1 m) lattice boom extension and 20 ft. (6.1 m) jib for total length of 130 ft. (39.6 m).
- **Telescope rated loads** for precise placement. Semi-fixed cylinder mounts decrease cylinder deflection under load and increase telescoping capacity.
- **Superior lifting performance** provided by rectangular full depth four-plate OMEGA boom that is welded inside and out.
- **New 6 x 4 truck carrier** has strong rigid frame utilizing a high strength rectangular box side rail construction, roomy lowline cab, sprung front suspension, 8'-0" (2.44 m) road width and road speeds to 49 mph (78.6 Kmph).
- **A duty-cycle machine** — OMEGA's powerful winches offer high line speeds, and pull. VOLUMATIK<sup>®</sup> hydraulic system provides optimum oil flow for fast crane functioning.
- **Total operator comfort** means less fatigue and greater production. Spacious OMEGA cab module allows placement of controls "in the palm of your hand", lots of leg and elbow room, and full vision of all activities.
- **Less downtime** — OMEGA is "Pit-Stop" maintenance-proven. It's industry's most serviceable crane — engineered for parts commonality, accessibility and fast tear-down.
- **Fast, solid set-up** with P&H outriggers. Excellent stability with 17'-10" (5.43 m) outrigger stance.

## Specifications

# specifications

## BOOM



**BOOM:** All boom sections are of full depth rectangular four-plate construction welded inside and out, with adjustable nylon-slider pads on top, bottom and sides. All powered sections are hydraulically self-proportioning, single lever controlled. Semi-fixed telescope cylinder mounts provide capacity to telescope rated loads. Boom point contains three 15" (381 mm) P.D. main sheaves and one 15" (381 mm) P.D. idler sheave. Sheaves are non-metallic with roller bearings.

Three (3) section boom, 32' (9.8 m) retracted length, 80' (24.4 m) extended length, consisting of one base section and 2 powered sections.

**BOOM EXTENSION (OPTIONAL):** 30' (9.1 m) swing-around tapered lattice structure with single 15" (381 mm) P.D. metallic boom point sheave with roller bearing. Easily installed from ground level by pivoting from its stored position on right side of boom base and pin connecting to boom point. For extending reach of boom.

**JIB (OPTIONAL):** 20' (6.1 m) underslung A-frame structure with single 15" (381 mm) P.D. metallic jib point sheave with bronze bushing, compression strut and guy cables. Pin and guy line connected. For extending reach of extension. Jib stored on carrier deck.

**AUXILIARY SHEAVE (OPTIONAL):** Single metallic sheave 11.25" (286 mm) P.D. with bronze bushing, bracket-mounted on boom point, for use with single auxiliary winch line.

### HOOK BLOCKS (OPTIONAL).

- A) 25 Ton — 3 sheaves with swivel hook and safety latch, for 5/8" (15.9 mm) wire rope.
- B) 10 Ton — 1 sheave with swivel hook and safety latch, for 1/2" (12.7 mm) or 5/8" (19mm) wire rope.
- C) 8.5 Ton — weighted hook with swivel and safety latch, for 1/2" (12.7 mm) wire rope.
- D) 5 Ton — weighted hook with swivel and safety latch, for 1/2" (12.7 mm) wire rope.

## UPPERSTRUCTURE



**OPERATOR'S CAB:** All-weather environmental cab of steel has hinged ceiling window, slide-by right side window with guard, large windows with full view in all directions and locking slide-by door. Safety glass used throughout. Operator's four-way adjustable seat has torsion suspension. Cab is 34.5 inches (876 mm) wide with a stand-up height of 56 inches (1422 mm) and is cushion-mounted for vibration dampening and noise reduction.

**CAB ACCESSORIES (STANDARD):** Cab contains all crane function controls in addition to mechanical boom angle indicator, electric windshield wiper, dash light, warning light and buzzer (monitoring hydraulic oil temperature, engine water temperature, air pressure and engine oil pressure), fuel gauge, master ignition switch, engine start button, two-speed controls for winches, circular level, hand throttle and electric remote control of outriggers, and electronic anti-two-block device.

**CAB ACCESSORIES (OPTIONAL):** Heater (diesel or propane fueled, thermostatically controlled), defroster fan, electric roof window wiper, windshield washer, seat belt, fire extinguisher, electronic boom angle indicator, electronic boom length indicator, load moment device, drum rotation indicators for main and auxiliary winches, vandal-proof glass (lexan), cold weather engine starting aid, floodlights, rear view mirrors, electric horn and rotary roof beacon and alcohol evaporator.



**CONTROLS:** In front of operator are foot pedals for boom hoist, swing brake, service brakes, and engine throttle. Mounted on the left hand side of front console are double-acting levers for swing (with optional horn button) and telescope. At the right are levers for auxiliary winch (optional), main winch, and boom hoist. Also on right console are main winch speed indicator and engine starting aid switch. On right side of seat are floor mounted levers for house lock and swing holding brake. Drum rotation indicators (optional) are mounted on auxiliary and main winch levers. At operator's right are console mounted switches for master ignition, windshield wiper (optional), defroster (optional), and outrigger controls. Also on console are engine start button, engine high temperature warning light, dash light, fuel gauge, air pressure gauge, circular level, and positive (air) hand throttle. Console has prewired removable modules for ease of service.



**MAIN WINCH:** P&H 1580 two speed, mounted on rear of revolving frame. Planetary gearing with equal speed power raising and lowering. Infinitely variable controlled speed. Spring applied, hydraulically released load holding multiple disc brake is automatic. Complete with 450' (137 m) wire rope.

Drum: 14.875" (378 mm) P.D. x 18.5" (470 mm) wide with 22.25" (565 mm) dia. flanges.

Wire Rope: 5/8" (16 mm) dia. 8 x 19 spin resistant, extra improved plow steel with 7 x 7 I.W.R.C.

Drum Capacity: 639 ft. (195 m) 5 layers.

Line Pull (Max.): 14,875 lb. (6741 kg) 1st layer (low speed).

Line Pull (Permissible): 8,600 lb. (3924 kg) per part of line.

Line Speed Up (Maximum):

High speed - 515 fpm (157 m/m) 5th layer (high speed).

**AUXILIARY WINCH (OPTIONAL):** P&H 1580 see above.

**AUXILIARY WINCH (OPTIONAL):** P&H 1080 single speed mounted on counterweight. Planetary gearing with equal speed power raising and lowering. Infinitely variable controlled speed. Spring applied, hydraulically released load holding multiple disc brake is automatic. Complete with 360' (110 m) wire rope and additional boom point idler sheave.

Drum: 11.25" (286 mm) P.D. x 16.5" (419 mm) wide with 16.75" (425 mm) dia. flanges.

Wire Rope: 1/2" (12.7 mm) dia. 8 x 19 spin resistant, extra improved plow steel with 7 x 7 I.W.R.C.

Drum Capacity: 543 ft. (165 m) 5 layers.

Line Pull (Max.): 10,500 lb. (4761 kg) 1st layer.

Line Pull (Permissible): 6,200 lb. (2812 kg) per part of line.

Line Speed Up (Maximum):

High speed - 360 fpm (110 m/m) 5th layer.



**BOOM HOIST:** One 9" (229 mm) I.D. cylinder, double-acting. Hydraulically powered raising and lowering with holding valve.

**BOOM TELESCOPE:** Two 5.75" (146 mm) I.D. cylinders — double acting. Hydraulically powered extending and retracting with holding valve. Supplied by a single hose loop.



**SWING UNIT:** Hydraulic motor driving through 36:1 planetary gear reducer to pinion gear. 360° continuous rotation to 3.13 RPM.

**SWING GEAR:** External cut spur gear with 136 teeth 45.3" (1151 mm) P.D. Dust cover is available (optional).

**SWING BRAKE:** STANDARD — Caliper disc brake mounted on swing gear reducer, manually applied with swing brake pedal for slow dynamic stopping and swing brake lever for static holding. Hydraulically released by swing lever engagement.

**HOUSE LOCK:** Two position (front and rear) pin-in-hole lock manually engaged with house lock lever in cab. A positive 360° position lock is available to meet New York city code (optional).

**ROTARY MANIFOLD:** Sealed rotary swivel for air and hydraulic hose connections between rotating upper and carrier. Quickly removable from above or below for servicing. Electrical swivel is mounted on top of air and hydraulic swivel.

**FASTENING TO LOWER:** Single row ball bearing integral with swing gear. Welded to carrier frame and bolted to rotating frame. Bearing is protected from dust by labyrinth seal.

**COUNTERWEIGHT:** STANDARD — 3,552 lb. (1611 kg) with main winch only, 2,585 (1172 kg) with both main and auxiliary winches. Mounted on revolving frame. OPTIONAL — 5,917 lb. (2685 kg) with main winch only, 4,950 lb. (2245 kg) with both main and auxiliary winches.

**Optional -** 5,883 lb. (2668 kg) removable counterweight with main winch only, 5,375 lb. (2438 kg) with both main and auxiliary winches. P&H 1580 auxiliary winch not available with this counterweight.

**CARRIER**

P&amp;H 6 x 4

**FRAME:** All-welded unitized construction assures rigidity and permanent alignment of swing bearing and rotating upper machinery. Fabricated of rectangular main frame beams of high strength 80,000 psi minimum yield alloy steel and reinforced with box cross members of high strength 80,000 psi minimum yield alloy steel.

**LIGHTS:** Dual headlights, tail lights, stop lights, front and rear directional signals with emergency flashers, rear license plate light, front, rear and side clearance lights with integral reflectors, dome light, and front identification lights.

**EQUIPMENT (STANDARD):** Front bumper, full fenders, tow hooks front and rear, carrier-mount boom rack, and sliding engine hood.

**EQUIPMENT (OPTIONAL):** Back-up warning device, cold weather starting aid, fire extinguisher, spare wheel, hydraulic front stabilizer and float (required for 360° ratings), windshield washer, air dryer, tool box, and sound reduction package (82 DbA.)



**CAB:** Low profile environmental cab of steel construction is mounted forward of the front suspension on the left side of the carrier frame. Cab is cushion mounted for vibration dampening and noise reduction. Large safety glass windows are used throughout, providing full view in all directions. Operators four-way adjustable seat has torsion suspension.

**CAB EQUIPMENT:** Contains all roading controls and instrumentation. Includes illuminated instrument panel with speedometer, tachometer, hour meter, voltmeter and warning light, three (3) air pressure gauges with warning lights, fuel gauge, oil pressure gauge with warning lights, water temperature gauge with warning lights, master ignition switch, engine start button. Panel also includes switches for highway lights, dome light, windshield wiper and washer (opt.), engine starting aid (opt.), heater, defroster, turn signals. Right side console includes inter-axle differential lock, transmission shift lever and parking brake. Other cab equipment includes cigarette lighter, engine condition warning alarm, air horns, seat belt and West Coast rear view mirror.



**HYDRAULIC OUTRIGGERS:** Four (4) independent assemblies that hydraulically extend out horizontally from carrier frame and down vertically to form a stable working platform. Four (4) double acting hydraulic cylinders provide independent horizontal beam movement and four (4) provide vertical rod movement. Vertical cylinders are equipped with holding valves. Cylinders are actuated by electric solenoid directional control valves operated from operator's cab console switches or control stations on either side of carrier.

**OUTRIGGER BEAMS:** 80,000 PSI min. yield high strength alloy steel box extending to a maximum of 8'11" (2.71 m) from center of carrier (with machine fully raised on outriggers).

**OUTRIGGER FLOATS:** Removable floats with storage on carrier. Float size is 20.25" (514 mm) square.

**FRONT AXLE:** Rockwell FL-931 forged balanced section I-beam.

**REAR AXLE:** Rockwell SQ100 single reduction, ratio 7.2:1 with inter-axle differential.

**SUSPENSION:** Front — Reyco multi-leaf spring mounted with torque rods. Rear — Hendrickson solid bogie, mounted tandem with torque rods.

**STEERING:** Ross 32.5:1 hydraulic powered gear and integral valve with Garrison dual hydraulic power assist cylinder, 18" (457 mm) diameter steering wheel.

**SERVICE BRAKES:** Rockwell Stopmasters on front. Maxi safety brakes on rear. Air on all six wheels — shoe type with separate front and rear air reservoirs for safety.

**PARKING BRAKES:** Maxi-spring set, air release on rear wheels.

**TIRES: Standard** — Front (2) and Rear (4) 15.00 x 22.5 super single bias 16 ply load range H. (Not for use with 6200 lb. counterweight).  
**Optional** — Front (2) and Rear (4) 16.5 x 22.5 super single bias 16 ply load range H.

Front (2) 16.5 x 22.5 super single bias 16 ply load range H and Rear (8) 10.00 x 20 dual bias 12 ply load range F.

Front (2) 15.00 x 22.5 super single bias 16 ply load range H and Rear (8) 10.00 x 20 dual bias 12 ply load range F.

Front (2) 15R x 22.5 super single radial 18 ply load range J and Rear (8) 10R x 20 dual radial 14 ply load range G.

Front (2) and Rear (4) 15R x 22.5 super single radial 18 ply load range J. (Not for use with 6200 lb. counterweight).

**POWER PLANT:**

ENGINE:	STANDARD	OPTIONAL
Make		Caterpillar Diesel
Model	3208NA	3208NA (Calif.)
Type	Direct Injection Diesel	
No. of Cylinders	8	
Bore x Stroke, In.	4.5 x 5.0	
mm	(114 x 127)	
Displacement, In. <sup>3</sup>	636	
liters	10.4	
Cycles	4	
Air Induction	Naturally Aspirated	

**TRANSMISSION:**

Make	Fuller
Model	RT6613
	Road ranger
Speeds	13-speed Forward
	3-speed Reverse

**Clutch:** Spicer 14" (355.6 mm) single plate ceramic disc clutch.

**RATINGS:**

Horsepower, Gross	210 @ 2800 RPM	200 @ 2800 RPM
SAE (157 kw)		SAE (149 kw)

**PERFORMANCE:**

Speed and gradeability based on 50,000 pounds (22,679 kg) G.V.W. and may vary due to engine performance, vehicle weights and tire options.

Low gear	2.7 MPH (4.4 km/h)	2.7 MPH (4.4 km/h)
High gear	49 MPH (78.6 km/h)	49 MPH (78.6 km/h)
Max. grade	69.6%	61.6%

**PUMP DRIVES:**

Driven off carrier engine with manual disconnect for travel.

Drive ratio 1:1

**ACCESSORIES:**

Air Cleaner	Two-stage dry type — replaceable element
Oil Filter	Full-flow with replaceable element
Fuel Filter	Heavy duty with replaceable element
Fuel Tank	FHWA approved (Left side of carrier) 60 gal. (227 liters) cap.
Cooling Radiator	Liquid-pressurized, recirculating by-pass
Fan	Fin and tube core, thermostat controlled
Starting	6 Blade, suction type, 26 in (660 mm) dia.
Charging	12 volt motor
	12 volt system with 65 amp. alternator, negative ground
Battery	1 — 385 amp. hour
Compressor, air	12.9 CFM
Governor, air	105-120 PSI

**VOLU-MATIC® HYDRAULIC SYSTEM:** This system utilizes 4 pumps and is designed to provide ample volume and pressure for optimum performance. A heavy duty power steering pump operating at 2800 rpm (engine full load) provides 8 gpm (30.3 lpm) to steering circuit. Three main gear type pumps are piggy-back mounted (use common driveshaft) and driven off front of engine at 2800 rpm (engine full load). The pump closest to engine provides 40 gpm (151.4 lpm) to boom hoist and telescope circuits. The shaft end pump of the piggy-back mounted tandem pump provides 80 gpm (302.8 lpm) to main and auxiliary winch circuits. The cover end pump of the tandem provides 29 gpm (109.8 lpm) to swing and outrigger circuits.

Total flow for this system at governed engine speed is 149 gpm (564 lpm). High pressure oil leaving the pump to the swing and outrigger circuits is filtered to 20 microns to protect seals in cylinders, valves and motors, before entering the functioning circuits. All returning oil (100%) is filtered in a bypass type filter to 10 microns before entering the reservoir.

The 115 gal. (435.3 liter) reservoir is located on mid right side of carrier. Pumps, valves, cylinders and motors are readily accessible and easy to service. Control valves are four way, three position type with low effort spools and pilot-operated relief valves for quick smooth response. A single spool pressure compensated valve is used for swing metering control. Cable linkage connects valves to control levers. Air to oil cooler is standard.



**VEHICLE WEIGHTS:** Basic machine includes standard engine, standard boom (forward in travel position), standard main winch and cable, standard tires, 30 gals. fuel, 115 gals. hydraulic fluid, and standard counterweight.

	G.V.W.	Front Axle	Rear Axle
	48,739 lb. (22,108 kg)	15,541 lb. (7,049 kg)	33,198 lb. (15,059 kg)
Effect on axle loads by adding on these items:			
1580 Auxiliary winch with cable	+98 lb. (45 kg)	-33 lb. (-15 kg)	+131 lb. (60 kg)
Opt. 5917 lb. counterweight (adj.)	+2365 lb. (1073 kg)	+1321 lb. (-588 kg)	+3686 lb. (+1672 kg)
Opt. 5883 removable counterweight (adj.)	-2329 lb. (-1056 kg)	+1327 lb. (602 kg)	-3656 lb. (-1658 kg)
Front 16.5 x 22.5 tires (2)	+54 lb. (24 kg)	+54 lb. (24 kg)	+0 lb. (0 kg)
30 ft. boom extension	+898 lb. (407 kg)	+731 lb. (331 kg)	+167 lb. (76 kg)
20 ft. jib (stored)	+862 lb. (391 kg)	+137 lb. (62 kg)	+725 lb. (329 kg)
Auxiliary sheave (with mounting)	+85 lb. (39 kg)	+145 lb. (66 kg)	-60 lb. (-27 kg)
8.5 ton weighted hook (stowed)	+220 lb. (100 kg)	+370 lb. (168 kg)	-150 lb. (-68 kg)
10 ton hook block (stowed)	+342 lb. (155 kg)	+575 lb. (261 kg)	-233 lb. (-106 kg)
25 ton hook block (stowed)	+425 lb. (193 kg)	+714 lb. (324 kg)	-289 lb. (-131 kg)
Propane heater with tank	+68 lb. (31 kg)	-13 lb. (6 kg)	+81 lb. (37 kg)
Hydraulic front Stabilizer and float	+348 lb. (158 kg)	+449 lb. (204 kg)	-101 lb. (-46 kg)
Tool box	+187 lb. (85 kg)	+240 lb. (109 kg)	-52 lb. (-24 kg)
Rear dual tires (8)			
10.00X20F	+659 lb. (299 kg)	0 lb. (0 kg)	+659 lb. (299 kg)
10.00R20G	+771 lb. (350 kg)	0 lb. (0 kg)	+771 lb. (350 kg)
Spare tire (wheel)	+312 lb. (142 kg)	-117 lb. (53 kg)	+429 lb. (195 kg)

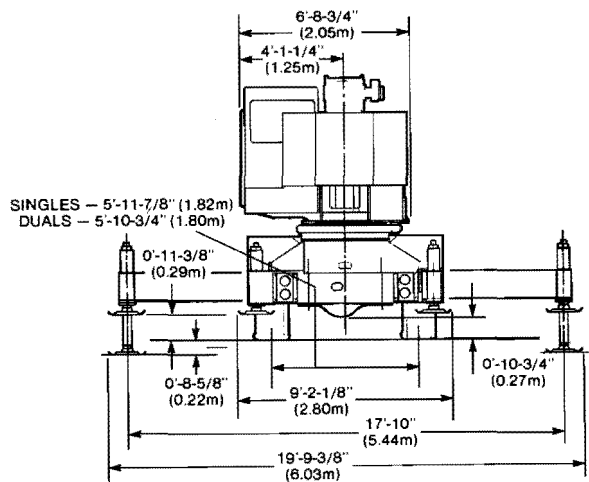
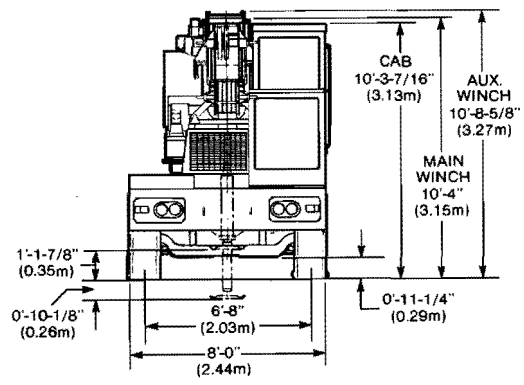

VEHICLE TURNING CIRCLE 65'-7" (19.99 m)  
 VEHICLE CLEARANCE CIRCLE (OVER BOOM POINT) 76'-8" (23.37 m)  
 DIMENSIONS ARE WITH STANDARD 15 x 22.5 TIRES  
 ADD 0'-0-3/4" (0.02 m) TO ALL HEIGHT DIMENSIONS FOR 16.5 x 22.5 TIRES  
 SUBTRACT 0'-0-3/8" (0.01 m) FROM REAR END HEIGHT DIMENSIONS FOR 10 x 20 DUAL TIRES

## general dimensions

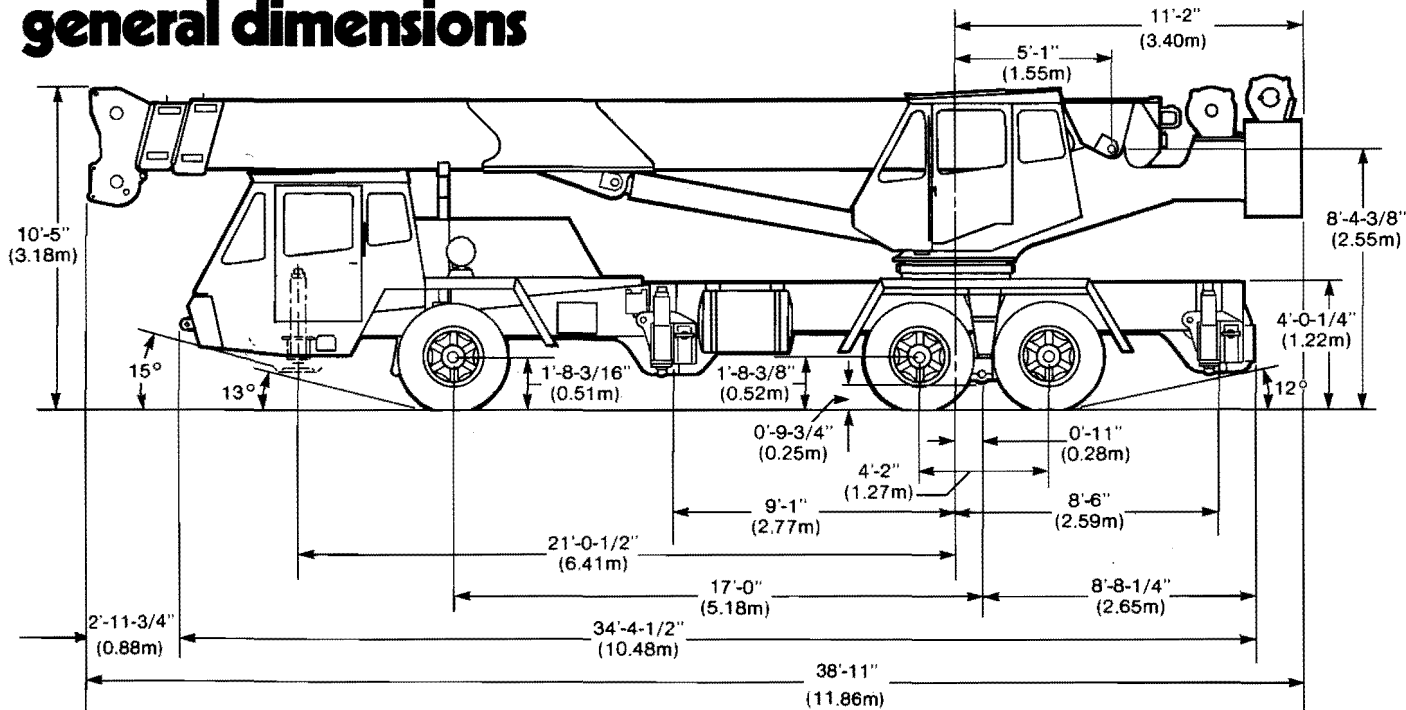

# operating instructions

This P&H crane meets the requirements of ANSI B30.15 (1973). Boom structure (boom, lattice extension and jib) has been tested per SAE J1063, machine stability tested per SAE J765. LOAD RATINGS shown apply only to machine as originally manufactured and equipped by Harnischfeger Corporation.

- LOAD RADIUS is horizontal distance from axis of rotation (before loading) to center of vertical hoist line (after loading). Actual working radii should be an accurate measurement.
- Boom, lattice extension and jib point height dimensions are measured from ground to center of load sheave.
- LOADED BOOM ANGLE is the angle between the boom base section and the horizontal axis after lifting rated load at rated radius. Loaded boom angles shown are with rated loads applied and provide an approximation of the LOAD RADIUS at the specified BOOM LENGTH (includes lattice extension). The boom angle before loading should be slightly greater to account for boom deflection.
- LOAD RATINGS shown are for machine with counterweight as shown, leveled and standing on firm, uniform supporting surface. Ratings are based on freely suspended loads and are not more than 85% of minimum tipping loads. Ratings above the bold horizontal line are based on machine's hydraulic or structural competence and not on machine stability (tipping conditions).
- To determine LOAD RATINGS in-between those shown on chart, proceed as follows:
  - for boom lengths not shown, use rating of next longer rated boom;
  - for load radii not shown, use rating of next longer rated radius.
- Deduct weight from LOAD RATINGS of all suspended load handling devices such as hooks, hookblocks, slings, buckets, etc. as they are considered part of the load. See table for deductions.
- Deduct weight from LOAD RATINGS of fixed boom attachments (jib, boom extension) either stowed or erected, as they reduce capacity of boom. See table for deductions.
- LOAD RATINGS shown make no allowance for such factors as wind effect on lifted loads, ground conditions, out-of-level, operating speed or conditions that could be detrimental to safe operation of this machine. The operator must judge these factors and reduce ratings accordingly.
- "ON OUTRIGGERS" LOAD RATINGS are based on outriggers fully extended and set at a distance of 8 ft. 11 in. (2.71 m) from longitudinal axis of carrier to vertical axis of outrigger float. Machine must be level and supported by outriggers with tires free of supporting surface.
- "ON TIRES" LOAD RATINGS are based on lift limitations and conditions of tires inflated to pressures shown in table. Over rear "Travel" ratings are limited to travel speed less than 2½ mph (4 kmph) on firm, level ground with load centered over rear of machine and load restrained from swinging.
- Maximum JIB LOAD RATINGS are based on structural competence. Ratings at any radius shall not exceed BOOM LOAD RATINGS at same radius and shall not exceed maximum ratings shown.
- Jibs are intended to increase lifting height — not load radius. Maximum JIB LOAD RADIUS shall not exceed maximum BOOM LOAD RADIUS of boom length on which jib is mounted. Jib ratings are based on boom angle.
- For bucket ratings on jib, deduct 20% from maximum JIB LOAD RATINGS.
- Method of telescoping boom is hydraulically synchronous with each section extendible a distance of 24 ft. (7.32 m). See rating chart.
- The maximum load which may be telescoped is limited by hydraulic pressure, boom angle and lubrication. It is safe to telescope any load within limits of load rating chart.

## areas of operation

### ON OUTRIGGERS

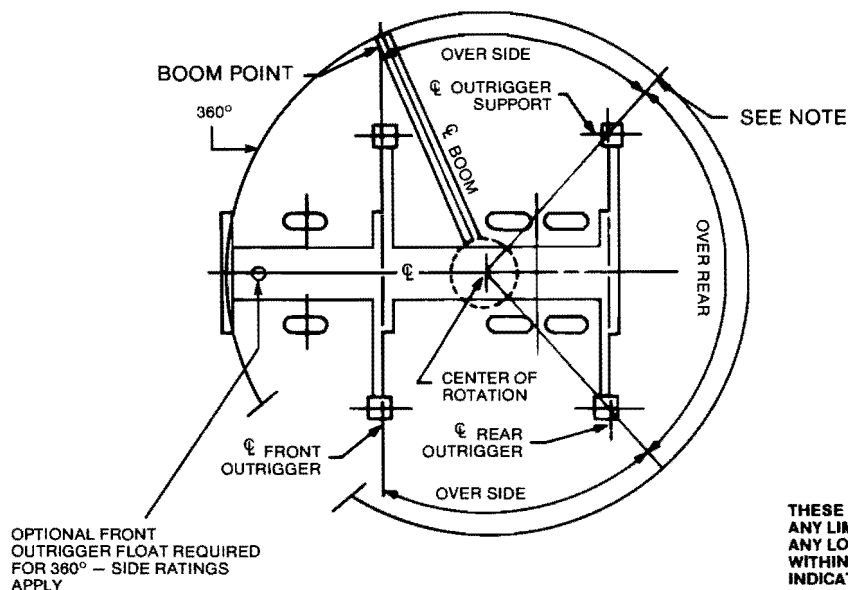

### ON TIRES

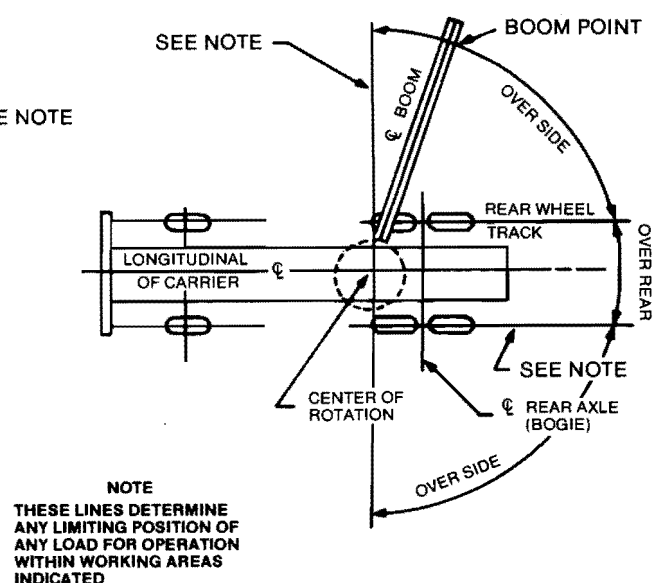



# working ranges

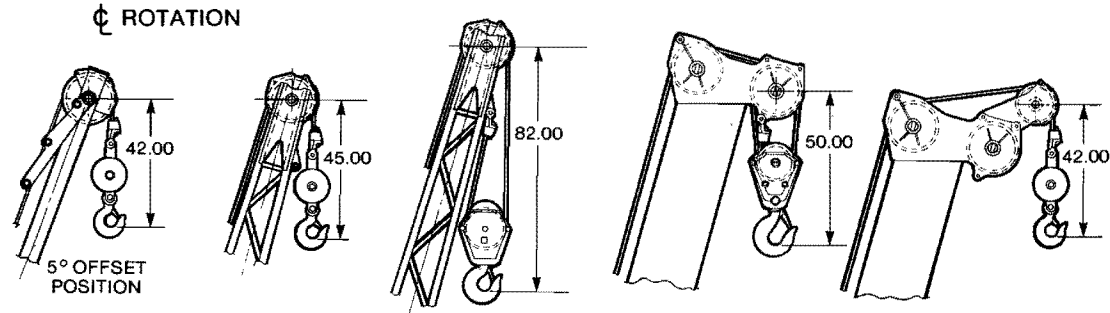
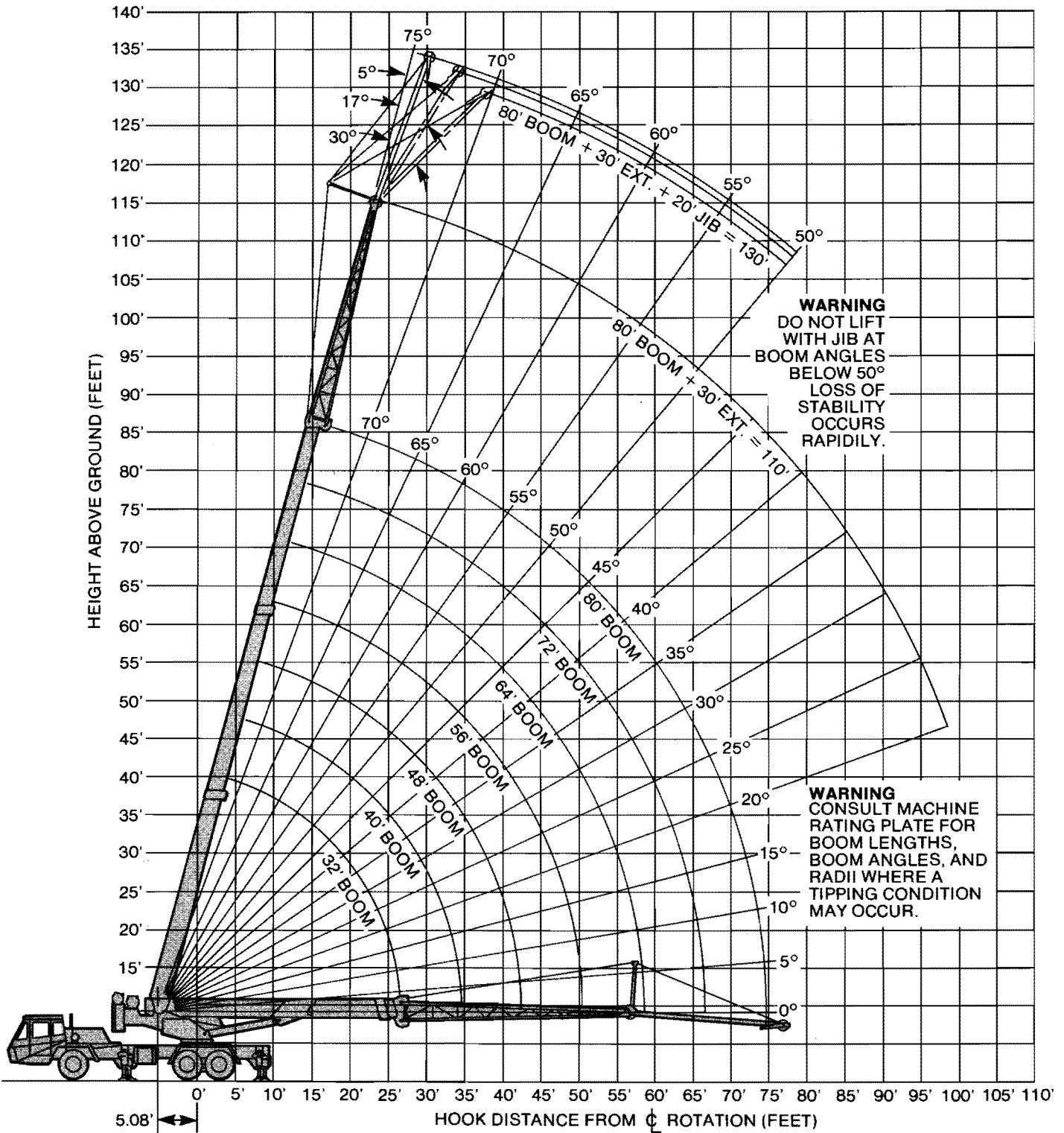

105J1438



## Jib ratings

MAXIMUM LOAD RATINGS IN POUNDS			
Minimum Boom Angle	JIB ANGLE OFFSET		
	5°	17°	30°
75°	6200	6000	5100
70°	5500	5000	4500
65°	3700	3500	3300
60°	2700	2500	2300
55°	1800	1700	1600
50°	1200	1100	1000

1. MAXIMUM JIB LOAD RATINGS ARE BASED ON STRUCTURAL COMPETENCE AND DO NOT EXCEED 85% OF TIPPING LOAD WITH FULLY EXTENDED OUTRIGGERS. USE OF OUTRIGGERS IS REQUIRED WHEN BOOM IS EQUIPPED WITH JIB.
2. FOR BUCKET RATINGS ON JIB, DEDUCT 20% FROM MAXIMUM JIB LOAD RATINGS.
3. **WARNING:** DO NOT LIFT WITH JIB AT BOOM ANGLES BELOW 50°. LOSS OF STABILITY OCCURS RAPIDLY.
4. **WARNING:** DO NOT EXCEED 95 FOOT LOAD RADIUS OVERSIDE WITH ERECTED JIB WITHOUT LOAD OR A TIPPING CONDITION WILL OCCUR.

## deductions to be made from rated loads

	<table border="1"> <thead> <tr> <th colspan="4">DEDUCTIONS TO BE MADE FROM MAIN BOOM RATED LOADS (IN POUNDS) (Hoisting from Boom Point)</th> </tr> <tr> <th colspan="2" rowspan="2">LATTICE EXTENSION</th> <th>STOWED</th> <th>ERECTED</th> </tr> <tr> <th>200</th> <th>1375</th> </tr> <tr> <th colspan="2">JIB</th> <td></td> <td>3750</td> </tr> <tr> <th colspan="2">AUX. BOOM PT. SHEAVE</th> <td></td> <td>100</td> </tr> <tr> <th>HOOK BLOCK</th> <th>ON BOOM POINT</th> <th>ON LATTICE EXTENSION</th> <th>ON JIB</th> </tr> <tr> <td>25 Ton 3 Sheave</td> <td>425</td> <td>—</td> <td>—</td> </tr> <tr> <td>10 Ton 1 Sheave</td> <td>342</td> <td>2175</td> <td>—</td> </tr> <tr> <td>8.5 Ton Ball Hook</td> <td>220</td> <td>1875</td> <td>4475</td> </tr> </thead> </table>	DEDUCTIONS TO BE MADE FROM MAIN BOOM RATED LOADS (IN POUNDS) (Hoisting from Boom Point)				LATTICE EXTENSION		STOWED	ERECTED	200	1375	JIB			3750	AUX. BOOM PT. SHEAVE			100	HOOK BLOCK	ON BOOM POINT	ON LATTICE EXTENSION	ON JIB	25 Ton 3 Sheave	425	—	—	10 Ton 1 Sheave	342	2175	—	8.5 Ton Ball Hook	220	1875	4475
DEDUCTIONS TO BE MADE FROM MAIN BOOM RATED LOADS (IN POUNDS) (Hoisting from Boom Point)																																			
LATTICE EXTENSION		STOWED	ERECTED																																
		200	1375																																
JIB			3750																																
AUX. BOOM PT. SHEAVE			100																																
HOOK BLOCK	ON BOOM POINT	ON LATTICE EXTENSION	ON JIB																																
25 Ton 3 Sheave	425	—	—																																
10 Ton 1 Sheave	342	2175	—																																
8.5 Ton Ball Hook	220	1875	4475																																
	<table border="1"> <thead> <tr> <th colspan="4">DEDUCTIONS TO BE MADE FROM LATTICE EXTENSION RATED LOADS (IN POUNDS) (Hoisting from Extension Point)</th> </tr> <tr> <th colspan="2" rowspan="2">JIB</th> <th>STOWED</th> <th>ERECTED</th> </tr> <tr> <th>575</th> <th>1250</th> </tr> <tr> <th>HOOK BLOCK</th> <th>ON BOOM POINT</th> <th>ON LATTICE EXTENSION</th> <th>ON JIB</th> </tr> <tr> <td>25 Ton</td> <td>325</td> <td>425</td> <td>—</td> </tr> <tr> <td>10 Ton</td> <td>250</td> <td>342</td> <td>—</td> </tr> <tr> <td>8.5 Ton</td> <td>175</td> <td>220</td> <td>1400</td> </tr> </thead> </table>	DEDUCTIONS TO BE MADE FROM LATTICE EXTENSION RATED LOADS (IN POUNDS) (Hoisting from Extension Point)				JIB		STOWED	ERECTED	575	1250	HOOK BLOCK	ON BOOM POINT	ON LATTICE EXTENSION	ON JIB	25 Ton	325	425	—	10 Ton	250	342	—	8.5 Ton	175	220	1400								
DEDUCTIONS TO BE MADE FROM LATTICE EXTENSION RATED LOADS (IN POUNDS) (Hoisting from Extension Point)																																			
JIB		STOWED	ERECTED																																
		575	1250																																
HOOK BLOCK	ON BOOM POINT	ON LATTICE EXTENSION	ON JIB																																
25 Ton	325	425	—																																
10 Ton	250	342	—																																
8.5 Ton	175	220	1400																																
	<table border="1"> <thead> <tr> <th colspan="4">DEDUCTIONS TO BE MADE FROM JIB RATED LOADS (IN POUNDS) (Hoisting from Jib Point)</th> </tr> <tr> <th>HOOK BLOCK</th> <th>ON BOOM POINT</th> <th>ON LATTICE EXTENSION</th> <th>ON JIB</th> </tr> </thead> <tbody> <tr> <td>25 Ton</td> <td>275</td> <td>375</td> <td>—</td> </tr> <tr> <td>10 Ton</td> <td>225</td> <td>300</td> <td>—</td> </tr> <tr> <td>8.5 Ton</td> <td>150</td> <td>200</td> <td>220</td> </tr> </tbody> </table>	DEDUCTIONS TO BE MADE FROM JIB RATED LOADS (IN POUNDS) (Hoisting from Jib Point)				HOOK BLOCK	ON BOOM POINT	ON LATTICE EXTENSION	ON JIB	25 Ton	275	375	—	10 Ton	225	300	—	8.5 Ton	150	200	220														
DEDUCTIONS TO BE MADE FROM JIB RATED LOADS (IN POUNDS) (Hoisting from Jib Point)																																			
HOOK BLOCK	ON BOOM POINT	ON LATTICE EXTENSION	ON JIB																																
25 Ton	275	375	—																																
10 Ton	225	300	—																																
8.5 Ton	150	200	220																																

**PCSA CLASS 12-91 three section full powered boom****rated crane loads in pounds — boom in overside and over rear work areas**

LOAD RADIUS (FEET)	BOOM LENGTH (IN FEET)															
	32'		40'		48'		56'		64'		64'		64'			
	LOADED BOOM ANGLE Δ°	RATED LOAD POUNDS	LOADED BOOM ANGLE Δ°	RATED LOAD POUNDS	LOADED BOOM ANGLE Δ°	RATED LOAD POUNDS	LOADED BOOM ANGLE Δ°	RATED LOAD POUNDS	LOADED BOOM ANGLE Δ°	RATED LOAD POUNDS	LOADED BOOM ANGLE Δ°	RATED LOAD POUNDS	LOADED BOOM ANGLE Δ°	RATED LOAD POUNDS		
10	66	50000	50000	71	50000	50000										
12	61	50000	50000	68	50000	50000	72	50000	50000	75	46000	46000				
15	55	43000	43000	63	43000	43000	68	43000	43000	72	43000	43000	74	35500		
20	42	30000	30000	54	30000	30000	61	30000	30000	66	30000	30000	70	30000		
25	24	22000	22800	44	22000	22800	54	22000	22800	60	22000	22800	65	22000		
30				32	15700	18000	46	15700	18000	54	15700	18000	59	15700		
35							36	11800	15800	47	11800	15800	54	11800		
40							23	9100	12500	39	9100	12500	48	9100		
45	CAUTION: FOR 32 FOOT BOOM LENGTH RATINGS TELESCOPE CYLINDERS MUST BE FULLY RETRACTED AND AGAINST STOPS.									29	7200	10200	41	7200		
50											13	5700	8400	33	5700	
55				WARNING: Do not exceed rated load radius for a rated load.											23	4600
60																

32R783

**WARNING: Main boom ratings must be reduced by weight of fixed boom attachments. See table.**WHEN LIFTING A LOAD, ALL POWERED SECTIONS OF THE BOOM MUST  
BE EXTENDED EQUALLY, WITHIN ONE (1) FOOT.**“on tires”****rated crane loads in pounds — main boom — without outriggers**

EQUIPPED WITH REAR 10.00 x 20 (F) or 10R x 20 (G) TIRES				LOAD RADIUS (FEET)	EQUIPPED WITH REAR 16.5 x 22.5 (H)			
STATIONARY RATINGS		TRAVEL RATINGS			STATIONARY RATINGS		TRAVEL RATINGS	
OVER REAR	OVER SIDE	OVER REAR			OVER REAR	OVER SIDE	OVER REAR	
		CREEP	2½ MPH			CREEP	2½ MPH	
18700	12300	15100	13400	10	12800	10900	12800	9600
15700	9600	13000	11500	12	11300	9000	11300	8300
11400	6700	10700	9300	15	9600	6600	9600	6800
7200	3700	7200	6800	20	7300	3800	7300	5000
4700	1800	4700	4700	25	4700	2000	4700	3600
3300	—	—	—	30	3300	—	—	—
2200	—	—	—	35	2200	—	—	—
1300	—	—	—	40	1300	—	—	—

32U2046

32U2043

**WARNING: DO NOT EXCEED RATED LOAD AT  
RADIUS SHOWN OR TIPPING WILL OCCUR.**





with lattice extension . . . and 6,200 lbs. counterweight

with outriggers fully extended and set

BOOM LENGTH (IN FEET)						LOAD RADIUS (FEET)
72'			80'			
LOADED BOOM ANGLE Δ°	RATED LOAD POUNDS		LOADED BOOM ANGLE Δ°	RATED LOAD POUNDS		
	SIDE	REAR		SIDE	REAR	
						10
						12
						15
72	27000	27000	75	25000	25000	20
68	22000	22800	71	21000	21000	25
64	15700	17500	67	15700	17200	30
59	11800	15800	63	11800	14800	35
54	9100	12500	58	9100	12500	40
48	7200	10200	54	7200	10200	45
43	5700	8400	49	5700	8400	50
36	4600	6900	44	4600	6900	55
28	3700	5800	38	3700	5800	60
16	2900	4800	31	2900	4800	65
			23	2300	4000	70
			11	1800	3500	74

RATINGS ABOVE THE HEAVY LINE ARE BASED ON STRUCTURAL COMPETENCE AND NOT ON MACHINE STABILITY.

FOR BOOM ANGLES NOT SHOWN, USE RATING OF NEXT LOWER BOOM ANGLE.

LOAD RADIUS (FEET)	LATTICE EXTENSION		
	FOR ALL BOOM LENGTHS 62 TO 110 FT.		
	LOADED BOOM ANGLE Δ°	RATED LOAD POUNDS	
SIDE		REAR	
FOR 110 FOOT BOOM ONLY			
30	73	12000	12000
35	71	10700	10700
40	68	9800	9800
45	65	8100	8100
50	62	6800	7500
55	59	5500	7100
60	56	4600	6400
65	53	3800	5700
70	49	3100	4900
74	46	2700	4400
80	41	2100	3700
85	37	1700	3200
90	32	1300	2800
95	26	1000	2400
100	19	↑	2000

**WARNING:**  
DO NOT EXCEED 95 FOOT RADIUS  
OVERSIDE AS TIPPING WILL OCCUR

32R783

**WARNING:** LIFTS WITH JIB OR BOOM EXTENSION IN WORKING POSITION ARE PROHIBITED.

TO HELP PREVENT TIPPING CONDITIONS WHEN "LIFTING ON TIRES", IT IS RECOMMENDED THAT —

1. MINIMUM BOOM LENGTHS BE USED, NOT EXCEEDING 48 FEET.
2. OUTRIGGERS BE EXTENDED AS FAR AS POSSIBLE AND CLEAR OF GROUND.

LOAD RATINGS DEPEND ON TIRE CAPACITY AND CONDITION, INFLATED PER TABLE.

SIZE	TIRE INFLATION (PSI)			
	STAT	CREEP	2½ MPH	ROADING
10.00x20 (F)	95	95	85	75
10R x 20 (G)	120	120	120	95
16.5x22.5 (H)	100	100	90	90

WHEN TRANSPORTING A LOAD, MACHINE MUST BE ON FIRM, LEVEL SURFACE WITH MECHANICAL HOUSELOCK ENGAGED AND LOAD CENTERED OVER REAR OF MACHINE AND RESTRAINED FROM SWINGING. DO NOT EXCEED 2½ MPH (4 KMPH) VEHICLE SPEED.

CREEP IS MOTION FOR LESS THAN 200 FT. (60.9 M) IN A 30 MIN. PERIOD AND NOT EXCEEDING 1 MPH.

RATINGS ABOVE THE HEAVY LINE ARE BASED ON STRUCTURAL COMPETENCE AND NOT ON MACHINE STABILITY.

PERMISSIBLE HOIST LINE LOAD IN POUNDS		
PARTS OF LINE	MAIN WINCH	AUXILIARY WINCH
1	8,600	6,200
2	17,200	12,000
3	25,800	
4	34,400	
5	43,000	
6	50,000	

HOIST LINE WIRE ROPE		
TYPE	MAIN	AUXILIARY
	¾"-8 x 19 IWRC	P&H TYPE 25 ½"-8 x 19 IWRC
BREAKING STRENGTH	36,200	23,400
PERMISSIBLE STRENGTH	10,343	6,686