



View thousands of Crane Specifications on FreeCraneSpecs.com

Series 600D: National Telescoping Crane

America's Leading Manufacturer of Truck-Mounted Hydraulic Cranes.

600D



National Pride



NATIONAL CRANE
A Grove Worldwide Company



Why Buy a National Series 600D?



- **18-ton Rating** – The new 600D provides an 18-ton capacity at a five-foot radius.
- **New 85-foot Four-section Boom** – The longest in its size range. The longer boom allows the operator to perform more lifts without the use of a jib, reducing setup time and improving efficiency.
- **Internal Anti-two-block** – The patent-pending design, standard on the 600D, eliminates the external reel and wire. No more snagging the reel or wire on obstructions.
- **Adjustable Swing Speed** – A control knob located on the swing motor brake release valve can be easily adjusted to the crane operator's swing speed preference.
- **Stronger Torsion Box** – The stronger standard torsion box improves rigidity, reduces truck frame flex and eliminates the need for counterweight.
- **Speedy Reeve Boom Tip and Sheave Blocks** – These standard features simplify rigging changes.
- **Pre-painted Components** – Painting crane components before assembly reduces the possibility of rust, improves serviceability and enhances the appearance of the machine.
- **Self-lubricating "Easy glide" Wear Pads/Polymer Paint** – The standard self-lubricating pads, used in conjunction with National's specially formulated *Polymer Paint*,[†] reduce the conditions that cause boom chatter and vibration. The net result is smoother crane operation.
[†]Patent pending
- **Improved Serviceability** –
 - A removable winch allows the internal telescoping cylinder to be removed quickly, without dismantling the boom.
 - Bearings on the boom extend and retract cables can be greased through access holes in the boom side plates.
 - Internal anti-two-block wire routing eliminates damage potential.
 - The boom sheave case is open, allowing access to replace the internal anti-two-block wire and to observe internal boom components.
 - Pre-paint reduces rust.
 - Internal boom parts have been reduced, facilitating rebuilding the machine.
- **New State-of-the-Art Control Valve** – Provides smoother operation. The new design eliminates parts, reducing repair costs and improving the machine's serviceability.
- **National Crane Is the Market Leader** – National is number one in the production of commercial truck-mounted boom trucks. National has many programs and people directly and indirectly involved to provide our customers reliable products.
 - National has the boom truck industry's leading test program. Every structural part of the crane is cycle tested, some up to 60,000 cycles at full capacity. In addition to cycle testing, each model is subjected to state-of-the-art strain gauge testing that measures metal deformation as small as one one-millionth of an inch. The net result is that weak areas are caught in test, not on job sites where costly downtime occurs.
 - All outrigger, lift and telescoping cylinders are manufactured by National Crane, so that the seals, packing glands, and end plates are traced for accurate shipment of replacement parts.
 - Parts are available for all National Crane machines, even if they are 35 years old.
 - National has a formalized quality program and is ISO 9001 approved.
- **National Crane is a Quality Product That Will Provide Years of Service.**

- 18 ton (16.33 t) maximum capacity
- 138 ft (42.06 m) maximum vertical reach*
- 94 ft (28.65 m) maximum vertical hydraulic reach*
- Hydraulic Capacity Alert system (HCA)
- Proportional boom extension
- High performance planetary winch
- Heavy-duty triple pump hydraulics

* Maximum vertical reach is ground-level to boom tip height at maximum extension and angle with outriggers/stabilizers fully extended.



600D Capacities

Load Rating Chart: Model 685D with 45-ft jib

Series 600D Load Rating Charts are available for all Model 638D, 647D, 649D, 657D, 675D and 685D cranes. National will send you a chart by FAX or mail on request - or you may secure needed load rating information through your nearest National dealer.

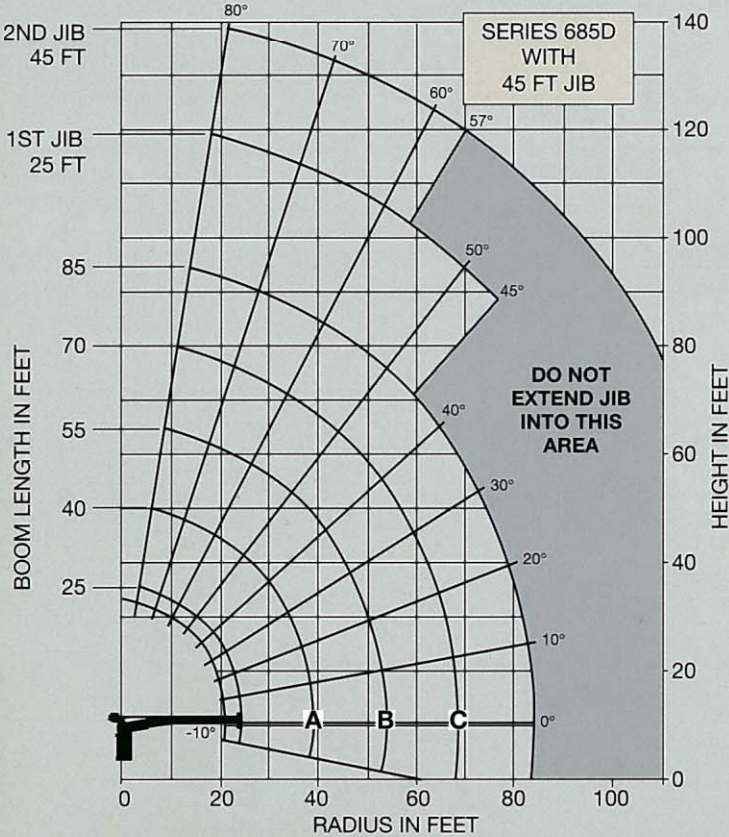

Caution:

- Do not operate crane booms, jib extensions, any accessories or loads within 10 ft (3m) of live power lines or other conductors of electricity
- Jib and boom capacities shown are maximum for each section
- Do not exceed capacities at reduced radii
- Load ratings shown on the load rating charts are maximum allowable loads with the outriggers properly extended on a firm, level surface and the crane leveled and mounted on a factory-recommended truck
- Always level the crane with the level indicator located on the crane
- The operator must reduce loads to allow for factors such as wind, ground conditions, operating speeds and their effects on freely suspended loads
- Overloading this crane may cause structural collapse or instability
- Weights of any accessories attached to the boom or loadline must be deducted from the load chart capacities
- Do not exceed jib capacities at any reduced boom lengths
- Do not deadhead lineblock against boom tip when extending boom or winching up
- Keep at least three wraps of loadline on drum at all times
- Use only specified cable with this machine
- Maximum capacity with Burst-of-Speed is 3,000 lb (1361 kg) on single part line

LOAD RATINGS

Load Radius (Feet)	Loaded Boom Angle	A			B			C		
		25 Ft Boom (Lb)	Loaded Boom Angle	40 Ft Boom (Lb)	Loaded Boom Angle	55 Ft Boom (Lb)	Loaded Boom Angle	70 Ft Boom (Lb)	Loaded Boom Angle	85 Ft Boom (Lb)
5	78.5	36,000								
8	71	23,000								
10	65.5	19,350	75.5	17,450						
12	60.5	16,550	73	14,650	78	13,550				
14	55	14,550	69.5	12,750	76	11,950				
16	50	13,000	66.5	11,500	74	10,350	78	9,300		
20	34.5	10,500	60	9,400	69.5	8,450	75	7,300	78	6,850
25			51	7,600	63.5	6,900	70.5	6,000	74.5	5,450
30			41	6,250	55	5,550	65.5	5,100	71	4,450
35			28.5	5,050	51	4,800	61.5	4,300	67.5	3,800
40					44	4,000	56.5	3,700	63.5	3,250
45					35.5	3,450	51.5	3,150	60	2,950
50					24.5	2,750	45.5	2,750	55.5	2,500
55							39.5	2,300	51	2,150
60							32	2,000	46.5	1,900
65							22	1,600	41.5	1,600
70									36	1,350
75									29	1,050
80									20	850
	0	6,550	0	3,200	0	1,600	0	700		

Load Radius (Feet)	Loaded Boom Angle	25 Ft Jib (Lb)	Loaded Boom Angle	45 Ft Jib (Lb)
25	78	2,800		
30	75.5	2,500	78.5	1,700
35	73	2,200	76	1,500
40	70	1,900	74	1,300
45	67.5	1,600	71.5	1,100
50	64.5	1,400	69.5	1,000
55	61.5	1,200	67	900
60	58.5	1,000	64.5	800
65	55.5	800	62.5	700
70	52	700	59.5	600
75	48.5	600	57	500
80	45	500		

* Shaded areas are structurally limited capacities.



Mounting Configurations

The configurations are based on the Series 600D with an 85% stability factor. The complete unit must be installed in accordance with factory requirements and a test performed to determine actual stability and counterweight requirements since individual truck chassis vary.

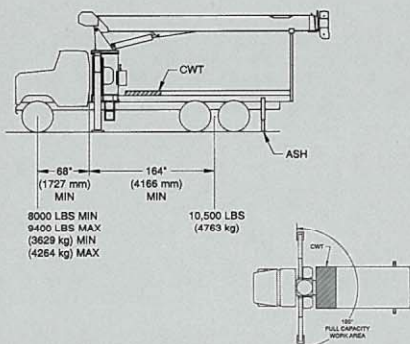

Configuration 1 – All boom lengths, other than 675D

Working area	180°
Gross Axle Weight Rating Front	14,000 lb (6350 kg)
Gross Axle Weight Rating Rear	34,000 lb (15 422 kg)
Gross Vehicle Weight Rating	48,000 lb (21 773 kg)
Wheelbase	232 in (589 cm)
Cab to Axle/trunnion (CA/CT)	164 in (417 cm)
Frame Section Modulus (SM) under crane w/110,000 PSI (758 MPa)	15.9 in ³ (261 cm ³)
Frame Section Modulus (SM) over rear stabilizers w/110,000 PSI (758 MPa)	13 in ³ (213 cm ³)
Stability Weight, Front	8,000 lb (3629 kg) minimum*
Stability Weight, Rear	10,500 lb (4763 kg) minimum*
Estimated Average Final Weight	35,000 lb (15 876 kg)

This configuration allows the installation of the Series 600D by using the standard subbase for 18' bed or the subbase for a 20' bed. In most cases, the chassis will not require reinforcing and the amount of counterweight required is minimized, increasing payload capabilities. Requires rear stabilizer.

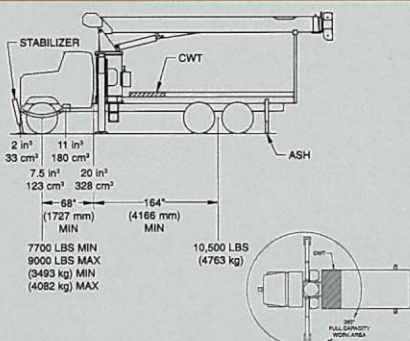

Configuration 2 – All boom lengths, other than 675D

Working area	360°
Gross Axle Weight Rating Front	14,000 lb (6350 kg)
Gross Axle Weight Rating Rear	34,000 lb (15 422 kg)
Gross Vehicle Weight Rating	48,000 lb (21 773 kg)
Wheelbase	232 in (589 cm)
Cab to Axle/trunnion (CA/CT)	164 in (417 cm)
Frame Section Modulus (SM) under crane w/110,000 PSI (758 MPa)	20 in ³ (328 cm ³)
Frame Section Modulus (SM) over rear stabilizers w/110,000 PSI (758 MPa)	13 in ³ (213 cm ³)
Stability Weight, Front	7,700 lb (3493 kg) minimum*
Stability Weight, Rear	10,500 lb (4763 kg) minimum*
Estimated Average Final Weight	36,000 lb (16 329 kg)

This mount requires front stabilizer, proper subbase, and additional counterweight in the underside of the bed for full capacity 360° around the truck. Front stabilizer gives the machine a solid base, helping the operator control loads. Requires rear stabilizer.

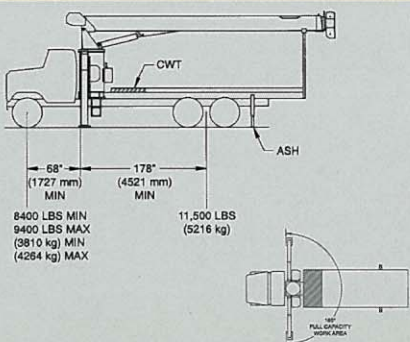

Configuration 3 – 675D (Add SFO for 360° Stability)

Working area	180°
Gross Axle Weight Rating Front	14,000 lb (6350 kg)
Gross Axle Weight Rating Rear	34,000 lb (15 422 kg)
Gross Vehicle Weight Rating	48,000 lb (21 773 kg)
Wheelbase	246 in (625 cm)
Cab to Axle/trunnion (CA/CT)	178 in (452 cm)
Frame Section Modulus (SM) under crane w/110,000 PSI (758 MPa)	15.9 in ³ (261 cm ³)
Frame Section Modulus (SM) over rear stabilizers w/110,000 PSI (758 MPa)	13 in ³ (213 cm ³)
Stability Weight, Front	8,400 lb (3810 kg) minimum*
Stability Weight, Rear	11,500 lb (5216 kg) minimum*
Estimated Average Final Weight	38,000 lb (17 237 kg)

This configuration allows the installation of the Series 675D by using the proper subbase for 22' bed. In most cases, the chassis will not require reinforcing and the amount of counterweight required is minimized, increasing payload capacities. Requires rear stabilizer. Add SFO for 360° stability.

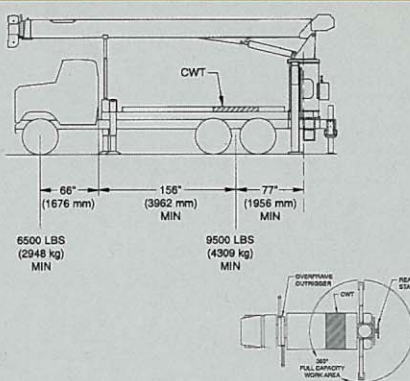

Configuration 4 – 600D Rear Mount

Working area	360°
Gross Axle Weight Rating Front	12,000 lb (5443 kg)
Gross Axle Weight Rating Rear	34,000 lb (15 422 kg)
Gross Vehicle Weight Rating	46,000 lb (20 865 kg)
Wheelbase	222 in (564 cm)
Cab to Axle/trunnion (CA/CT)	156 in (396 cm)
Frame Section Modulus (SM) under crane w/110,000 PSI (758 MPa)	15.9 in ³ (261 cm ³)
Frame Section Modulus (SM) over rear stabilizers w/110,000 PSI (758 MPa)	15.9 in ³ (261 cm ³)
Stability Weight, Front	6,500 lb (2948 kg) minimum*
Stability Weight, Rear	9,500 lb (4309 kg) minimum*
Estimated Average Final Weight	36,000 lb (16 329 kg)

This type of mount enables the operator to position the crane close to the load in tight working areas. 360° stability at full rated load can be attained with front out-and-down outriggers, heavy-duty, rear-mount subbase and a single rear stabilizer. Weights shown for front and rear axles are weights of the truck chassis and bed prior to installation of crane, subbase, front outriggers and rear stabilizer. Truck frame must have been, or be capable of being, lengthened to an AF of 106 inches (269 cm) minimum.

Notes:

- Gross Vehicle Weight Rating (GVWR) is dependent on all components of the vehicle (axles, tires, springs, frame, etc.) meeting manufacturers' recommendations; always specify GVWR when purchasing trucks
- Diesel engines require a variable speed governor and energize-to-run fuel solenoid for smooth crane operation; electronic fuel injection requires EET engine remote throttle
- All mounting data is based on a National Series 600D with an 85 percent stability factor
- The complete unit must be installed in accordance with factory requirements, and a test performed to determine actual stability and counterweight requirements per SAE J765; contact the factory for details
- Transmission neutral safety interlock switch is required with optional remote control

* Estimated axle scale weights prior to installation of crane, stabilizers and subbase for 85% stability.



Boom and Jib Combinations Data

Available in six basic models: 638D 3-section, 647D 3-section, 649D 4-section, 657D 3-section, 675D 3-section and 685D 4-section.

Model 638D — Equipped with a 16-38 ft (4.88-11.58 m) three-section boom. This model can be equipped with a 15 ft (4.57 m) single-section jib or a 15-25 ft (4.57-7.62 m) two-section jib. Maximum tip height w/25 ft (7.62 m) jib is 73 ft (22.25 m).

16-38 ft (4.88-11.58 m) three-section boom



16-38 ft (4.88-11.58 m) three-section boom



6FJ15 15 ft (4.57 m) jib

16-38 ft (4.88-11.58 m) three-section boom



6FJ25M 15-25 ft (4.57- 7.62 m) two-section jib

Model 647D — Equipped with a 19-47 ft (5.79-14.33 m) three-section boom. This model can be equipped with an 18 ft (5.49 m) single-section jib or an 18-29 ft (5.49-8.84 m) two-section jib. Maximum tip height w/29 ft (8.84 m) jib is 86 ft (26.21 m).

19-47 ft (5.79-14.33 m) three-section boom

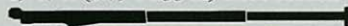

19-47 ft (5.79-14.33 m) three-section boom



6FJ18 18 ft (5.49 m) jib

19-47 ft (5.79-14.33 m) three-section boom



6FJ29M 18-29 ft (5.49-8.84 m) two-section jib

Model 675D — Equipped with a 29-75 ft (8.84-22.86 m) three-section boom. This model can be equipped with a 25 ft (7.62 m) single-section jib or a 25-45 ft (7.62-13.72 m) two-section jib. Maximum tip height w/45 ft (13.72 m) jib is 128 ft (39.06 m).

29-75 ft (8.84-22.86 m) three-section boom



29-75 ft (8.84-22.86 m) three-section boom



6FJ25 25 ft (7.62 m) jib

29-75 ft (8.84-22.86 m) three-section boom



6FJ45M 25-45 ft (7.62-13.72 m) two-section jib

Model 685D — Equipped with a 25-85 ft (7.62-25.91 m) four-section boom. This model can be equipped with a 25 ft (7.62 m) single-section jib or a 25-45 ft (7.62-13.72 m) two-section jib. Maximum tip height w/45 ft (13.72 m) jib is 138 ft (42.07 m).

25-85 ft (7.62-25.91 m) four-section boom



25-85 ft (7.62-25.91 m) four-section boom



6FJ25 25 ft (7.62 m) jib

25-85 ft (7.62-25.91 m) four-section boom



6FJ45M 25-45 ft (7.62-13.72 m) two-section jib

Note: Maximum tip height is measured with outriggers/stabilizers fully extended.

5

600D Winch Data

- All winch pulls and speeds in this chart are shown on the third layer
 - Winch line pulls would increase on the first and second layers
 - Winch line speed would decrease on the first and second layers
 - Winch line pulls may be limited by the winch capacity or the ANSI 5 to 1 cable safety factor (3.5 to 1 for optional 6x25 IWRC cable)
 - Hook blocks are rated at maximum capacity for the block
- Do not exceed rated cable pull with any block.**

Winch	Cable Supplied	Average Breaking Strength	1 Part Line	2 Part Line	3 Part Line	4 Part Line	5 Part Line
			Lift and Speed	Lift and Speed	Lift and Speed	Lift and Speed	Lift and Speed
Standard Planetary Winch	9/16" Diameter Rotation Resistant	38,500 lb (17 463 kg)	7,700 lb (3493 kg) 135 fpm (41.2 m/min)	15,400 lb (6985 kg) 68 fpm (20.7 m/min)	23,100 lb (10 478 kg) 45 fpm (13.7 m/min)	30,800 lb (13 971 kg) 34 fpm (10.4 m/min)	36,000 lb (16 330 kg) 27 fpm (8.2 m/min)
	Optional 9/16" Diameter 6x25 IWRC	29,750 lb (13 494 kg)	8,400 lb (3810 kg) 135 fpm (41.2 m/min)	16,800 lb (7620 kg) 68 fpm (20.7 m/min)	25,200 lb (11 421 kg) 45 fpm (13.7 m/min)	33,600 lb (14 515 kg) 34 fpm (10.4 m/min)	36,000 lb (16 330 kg) 27 fpm (8.0 m/min)
With "Burst-of-Speed"	Same as corresponding cable data shown above		3,000 lb (1361 kg) 206 fpm (62.8 m/min)	6,000 lb (2722 kg) 103 fpm (31.4 m/min)	9,000 lb (4082 kg) 69 fpm (21.0 m/min)	12,000 lb (5443 kg) 52 fpm (15.9 m/min)	15,000 lb (6804 kg) 41 fpm (12.5 m/min)

Winch	Bare Drum Pull	Allowable Cable Pull
With standard rotation resistant rope	10,200 lb (4627 kg)	7,700 lb (3493 kg)
With optional 6x25 IWRC rope	10,200 lb (4627 kg)	8,400 lb (3810 kg)

Block Type	Rating	Weight
Downhaul Weight	3.85 ton (3.49 t)	150 lb (68 kg)
1 Sheave Block	11.55 ton (10.48 t)	200 lb (91 kg)
2 Sheave Block	19.25 ton (17.46 t)	355 lb (161 kg)



Accessories

Cabled Remote Controls - A one-hand remote control is ideal where precise control and total load visibility are required.

- **Model R4** (adds winch control)

Radio Remote Controls - Eliminate the handling and maintenance concerns that accompany cabled remotes. Operate to a range of about 250 feet (76 m), varying with conditions.

- **Model R3R** (lift, turn, telescope)
- **Model R4BR** (adds winch control)

One-Person Basket - Strong but lightweight steel basket with 300 lb (139 kg) capacity, gravity hung with swing lock and full body harness.

- **Model B1-S**
- **Model 2B1-S** (for dual locking baskets)

Heavy-duty Personnel Basket - 1,200 lb (544 kg) capacity steel basket with four safety loops. Gravity leveling 72 x 42 inch (183 x 107 cm) platform. Fast attachment and secure locking systems. Load chart must show 2,300 lb (1043 kg) minimum to operate this accessory.

- **Model BSA-1**
- **Model BSA-R1** (provides rotation)

Pallet Fork - Manual leveling fork with adjustable throat and teeth, 4,400 lb (1996 kg) capacity.

- **Model MKF**

Loose Material Clam - Moves up to 2/3 yard³ (.50 m³) material. Bucket hooks easily to loadline and includes manual control hose reel.

- **Model LMC**

Hydraulic Oil Cooler - Automatic, self-contained radiator system with electric fans cools oil under continuous operation.

- **Model OC**

Continuous Rotation - Allows rotation of turret/boom without stop.

- **Model CR**

Burst-of-Speed Winch - Provides faster winch payout and pickup of unloaded cable. Increases line speed up to 60 percent over normal.

- **Model BOS**

Dimensions Specifications:

All dimensions are in inches (mm) unless otherwise specified.

MAX RATED LOAD MOMENT 3,318,949 IN LB (374 991 Nm)
MAX RATED ROTATIONAL TORQUE 220,944 IN LB (24 963 Nm)
THRUST @ MAX RATED LOAD MOMENT 8,228 LB (3732 Kg)
MAXIMUM THRUST 42,524 LB (19 289 Kg)

38' BOOM--16' RET 38' EXT [4.88 m -- 11.58 m]
47' BOOM--19' RET 47' EXT [5.79 m -- 14.33 m]
57' BOOM--23' RET 57' EXT [7.01 m -- 17.37 m]
75' BOOM--28' RET 75' EXT [8.74 m -- 22.86 m]
49' BOOM--16' RET 49' EXT [4.98 m -- 14.94 m]
85' BOOM--25' RET 85' EXT [7.72 m -- 25.91 m]

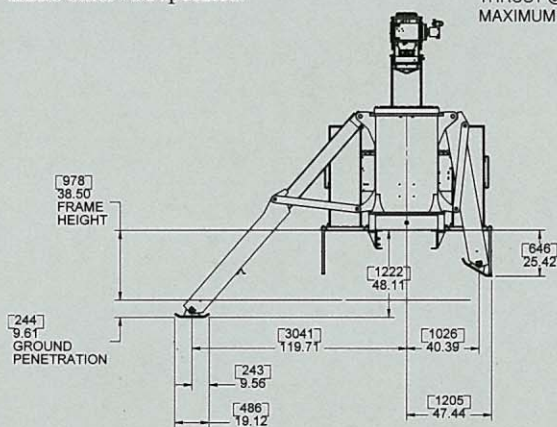

42.03 [1068] TAILSWING
MAINTAIN CLEARANCE
FOR TAILSWING

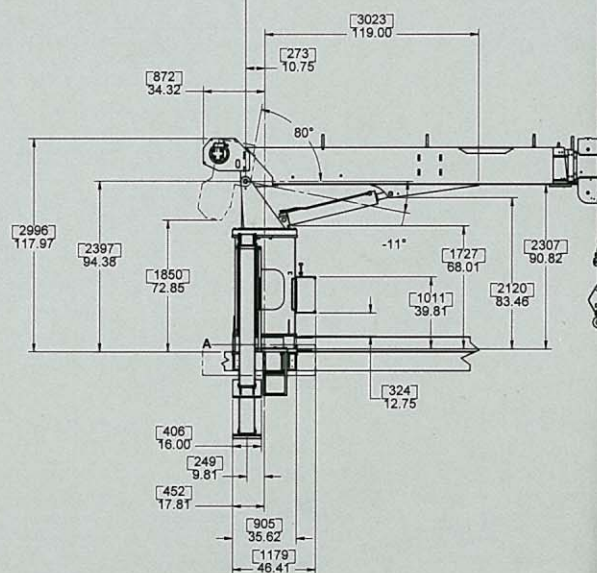
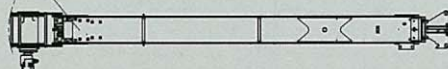

NATIONAL CRANE
A Grove Worldwide Company

Your National Dealer:

National
Crane is
ISO 9001
Certified

General Offices:

11200 North 148th Street
Waverly, NE 68462 USA
Phone: (402) 786-6300
FAX: (402) 786-6363
Email: sales@nationalcrane.com
Web: www.nationalcrane.com

National Crane reserves the right to change designs, prices and specifications at any time without notice.
Printed in U.S.A. Form No. 600D/0601/5M/AA/JN