

BLEED
TRIM

Boom and Jib Combinations Data

Available in two basic models.

Model 14100H — Equipped with a 30 ft 10 in to 100 ft (9.40-30.49 m) four-section boom. This model can be equipped with a 30 ft (9.15 m) single-section jib or a 30-54 ft (9.15-16.46 m) two-section jib. Maximum tip height w/30ft (9.15 m) jib is 137 ft (41.77 m), while maximum tip height w/30-54 ft (9.15-16.46 m) jib is 161 ft (49.08 m).

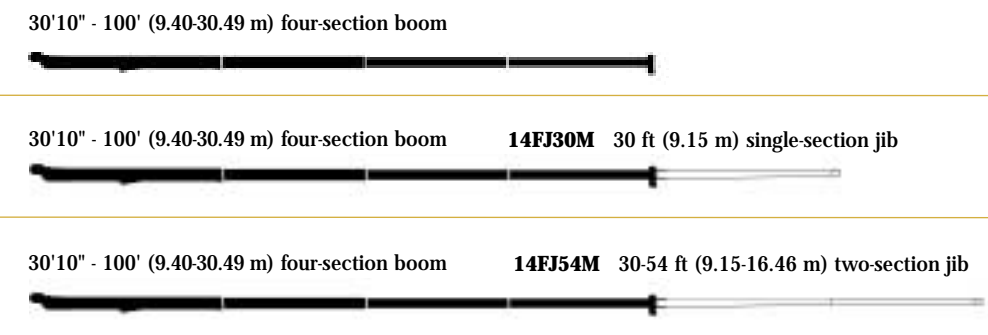

Model 14127H — Equipped with a 31 ft 7 in to 127 ft (9.63-38.72 m) five-section boom. This model can be equipped with a 30 ft (9.15 m) single-section jib. Maximum tip height w/ 30 ft (9.15 m) jib is 167 ft (50.91 m).

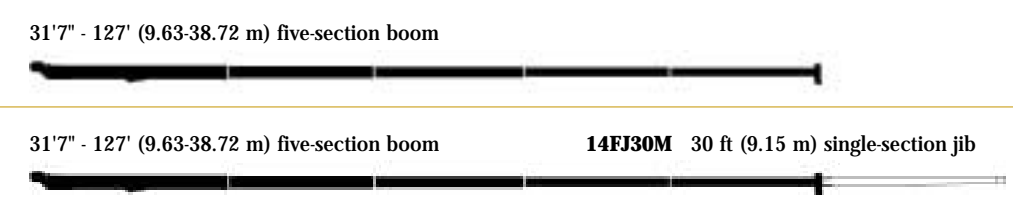

Note: maximum tip height is measured with outriggers/stabilizers fully extended.

1400H Winch Data

- Do not deadhead line block against boom tip when extending boom.
- Keep at least 3 wraps of loadline on drum at all times.
- Use only 5/8" diameter rotation-resistant cable with 45,400 pounds breaking strength on this machine.

Winch	Cable Supplied	Average Breaking Strength	Part Line							
			1 Part Line	2 Part Line	3 Part Line	4 Part Line	5 Part Line	6 Part Line	7 Part Line	8 Part Line
Standard Planetary Winch Low Speed	5/8" Diameter Rotation Resistant 18 x 19 IWRC	45,400 lb (20,593 kg)	9,000 lb (4,082 kg) 170 fpm (52 m/min)	18,000 lb (8,165 kg) 85 fpm (26 m/min)	27,000 lb (12,247 kg) 57 fpm (17 m/min)	36,000 lb (16,329 kg) 43 fpm (13 m/min)	45,000 lb (20,412 kg) 34 fpm (10 m/min)	54,000 lb (24,494 kg) 28 fpm (9 m/min)	63,000 lb (28,576 kg) 24 fpm (7 m/min)	66,000 lb (29,937 kg) 21 fpm (6 m/min)
Standard Planetary Winch High Speed	5/8" Diameter Rotation Resistant 18 x 19 IWRC	45,400 lb (20,593 kg)	4,400 lb (1,996 kg) 340 fpm (104 m/min)	8,800 lb (3,992 kg) 170 fpm (52 m/min)	13,200 lb (5,987 kg) 113 fpm (34 m/min)	17,600 lb (7,983 kg) 85 fpm (26 m/min)	22,000 lb (9,979 kg) 68 fpm (21 m/min)	26,400 lb (11,975 kg) 57 fpm (17 m/min)	30,800 lb (13,971 kg) 49 fpm (15 m/min)	35,200 lb (15,967 kg) 43 fpm (13 m/min)
All winch pulls and speeds in this chart are shown on the fourth layer. Winch line pulls would increase on the first, second and third layers. Winch line speed would decrease on the first, second and third layers. Winch line pulls may be limited by the winch capacity or the ANSI 5 to 1 cable safety factor. These are shown below:			Winch		Full Drum Pull		Allowable Cable Pull		Aux. Boom Head Downhaul Weight	
			Standard planetary		4,400 lb. (1,996 kg) (high speed) 9,000 lb. (4,082 kg) (low speed)		9,080 lb. (4,119 kg)		100 lb 180 lb 375 lb 640 lb 870 lb 970 lb	

Accessories

- Winch Drum Rotation Indicator - With indicators at each control station.**
 - **Model WDRI**
- Radio Remote Controls - Eliminate the handling and maintenance concerns that accompany cabled remotes. Operate to a range of about 250 feet (76 m), varying with conditions.**
 - **Model NB3R** (lift, turn telescope)
 - **Model NB4R** (adds winch control)
- One-Person Basket - Strong but lightweight steel basket with 300-lb. (136-kg) capacity, gravity hung with swing lock and full body harness.**
 - **Model B1-S**
 - **Model 2B1-S** (for dual locking baskets)
- Heavy-duty Personnel Basket - 1,200-lb. (544-kg) capacity on main boom, 500lb (227kg) on jib, steel basket with four safety loops. Gravity leveling 72" x 42-inch (183" x 107-cm) platform. Fast attachment and secure locking systems. Load chart must show at least 3,550 lb (1610 kg) minimum to operate this accessory on main boom; 2,150 lb (975 kg) on jib.**
 - **Model BSA-1**
 - **Model BSA-RI** (provides rotation)
- Pallet Fork - Manual leveling fork with adjustable throat and teeth, 4,400-lb. (1,996-kg) capacity.**
 - **Model MKF**
- Loose Material Clam - Moves up to 2/3 yard³ (.50 m³) material. Bucket hooks easily to loadline and includes control valve and boom-mounted hose reel.**
 - **Model LMC**
- Single Front Stabilizer - Attaches at front bumper location to provide 360° stability. Chassis requires extended front frame rails.**
 - **Model SFO**

Dimensions Specifications:
All dimensions are in inches (mm) unless otherwise specified.

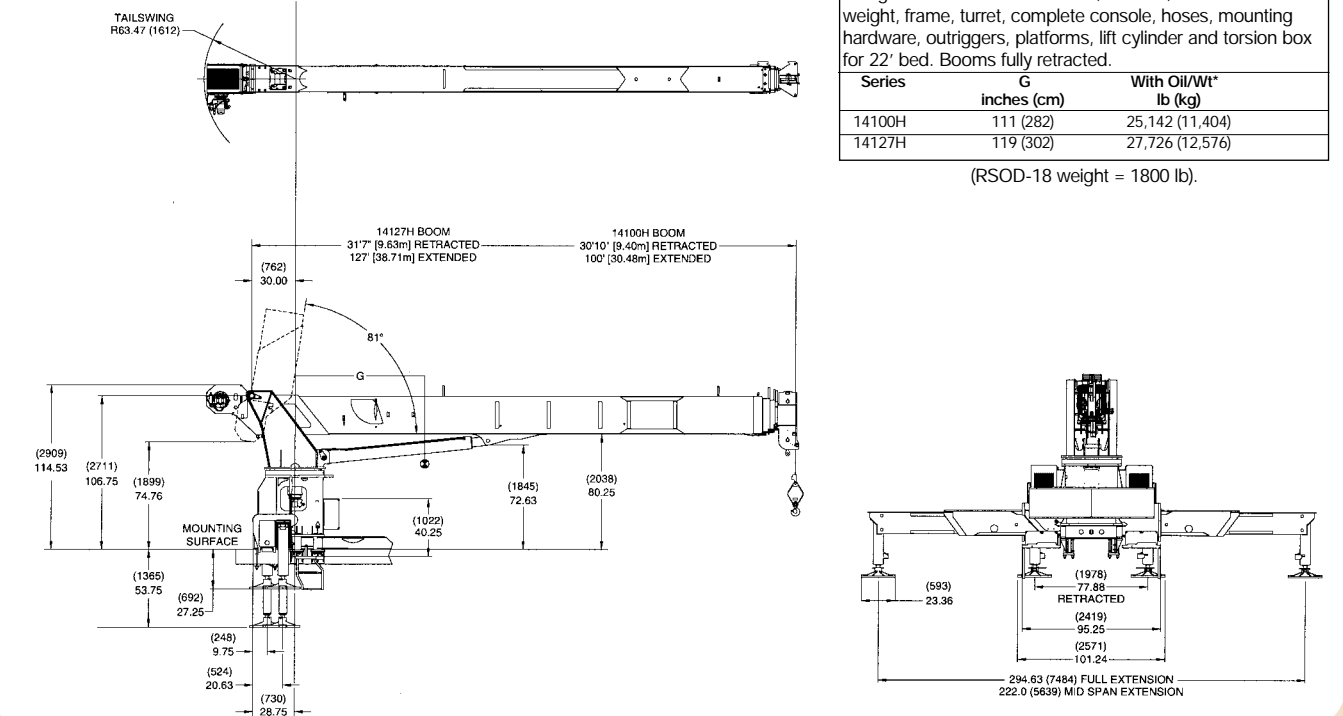

*Weight includes boom w/winch, loadline, 180lb downhaul weight, frame, turret, complete console, hoses, mounting hardware, outriggers, platforms, lift cylinder and torsion box for 22" bed. Booms fully retracted.

Series	G Inches (cm)	With Oil/Wt* lb (kg)
14100H	111 (282)	25,142 (11,404)
14127H	119 (302)	27,726 (12,576)

(RSOD-18 weight = 1800 lb.)



General Offices:
11200 North 148th Street
Waverly, NE 68462 USA
Phone: (402) 786-6300
FAX: (402) 786-6363
Email: sales@nationalcrane.com
Web: www.nationalcrane.com

Your National Dealer:

National Crane is ISO 9001 Certified

National Crane reserves the right to change designs, prices and specifications at any time without notice.
Printed in U.S.A. Form No. 1400H/1002/5M/AA/JN

Series 1400H: National Telescoping Crane

America's Leading Manufacturer of Truck-Mounted Hydraulic Cranes.

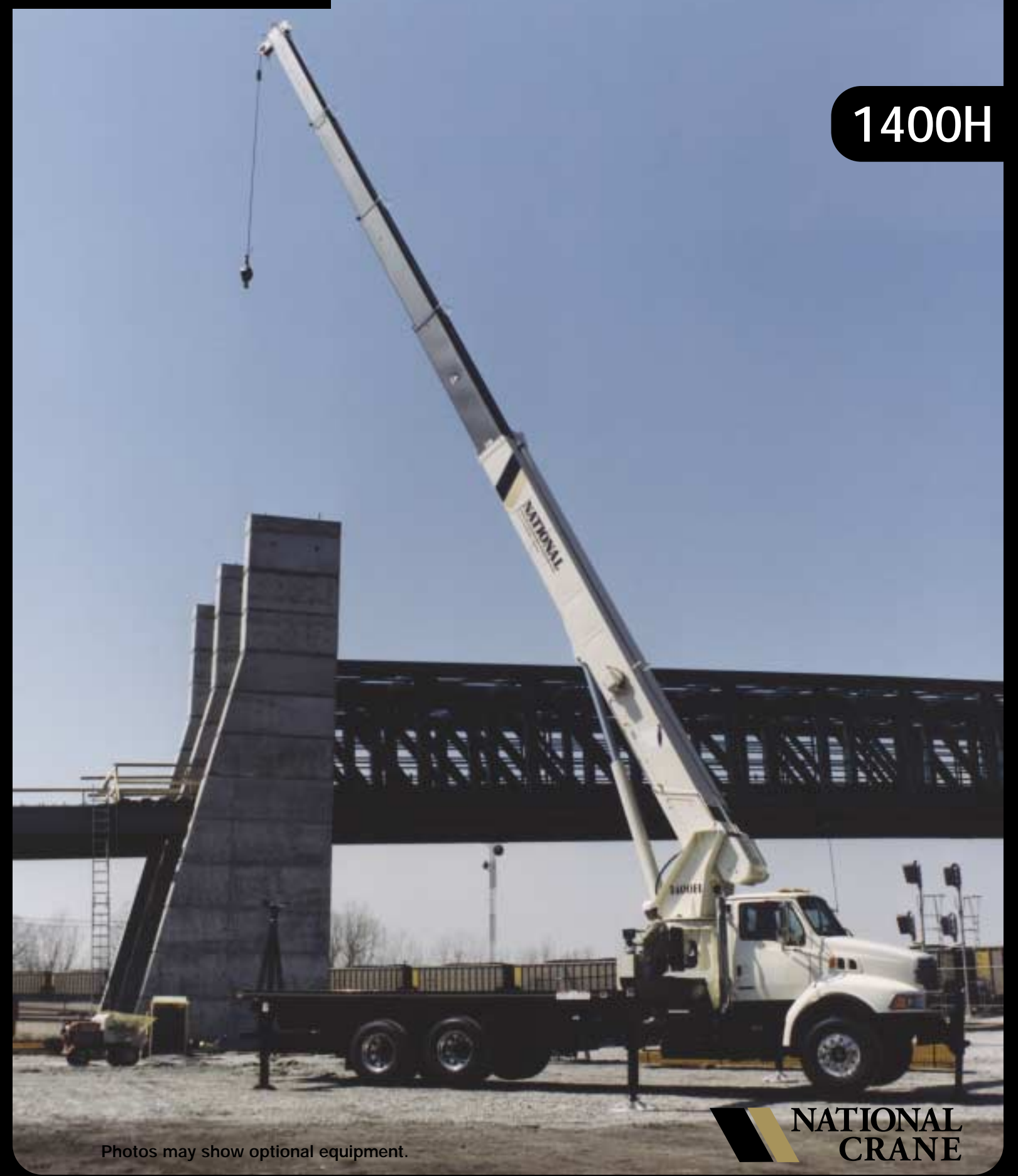

1400H

Photos may show optional equipment.



BLEED
TRIM

Why Buy a National Series 1400H?



- **33-ton Rating** – The new 1400H is a 33-ton machine, an 18% increase in capacity over the Series 1100.
- **New 127-foot Five-section Boom** – The longest in its size range. The longer boom allows the operator to perform more lifts without the use of a jib, reducing setup time and improving efficiency. A four-section 100-foot boom option is also available.
- **Overload Protection** – All National cranes are equipped with overload protection:
 - Load Moment Indicator (LMI) standard on all Series 1400H machines.
 - LMI display and CPU are weatherproof.
 - LCD display is visible in full or low light.
 - All crane load lifting values are displayed simultaneously.
- **Crossframe Outriggers** – Mainframe outriggers are crossframe H-style, with 24'6" (7.47 m) span, with mid-span setting of 18'6" (5.64 m). Rear stabilizers are H-style with 18'6" (5.64 m) span. Removable ball-and-socket aluminum outrigger pads on mainframe outriggers.
- **Self-lubricating "Easy glide" boom Wear Pads** – The self-lubricating boom pads, standard on the 1400H, reduce the conditions that cause boom chatter and vibration. The net result is smoother boom operation.
- **Internal Anti-two-block Wire** – This exclusive design, standard on the Series 1400H, routes the wire through the inside of the boom. No more snagging the wire on obstructions.
- **Rotation** – 375° non-continuous rotation is standard, with an option for continuous rotation.
- **Adjustable Swing Speed** – Standard on the 1400H. A control knob located on the swing motor brake release valve can be easily adjusted to the crane operator's swing speed preference.
- **Heavier Duty Torsion Box** – The stronger standard torsion box improves rigidity, reduces truck frame flex and reduces the need for counterweight.
- **Speedy-reeve Boom Tip and Sheave Blocks** – These standard features simplify rigging changes by decreasing the time needed to change line reeving.
- **Pre-painted Components** – Painting crane components before assembly reduces the possibility of rust, improves serviceability and enhances the appearance of the machine.
- **Oil Cooler** – Radiator mounted on truck frame with electric fan is standard, with an option to deduct the cooler for low duty-cycle applications.
- **Improved Serviceability** –
 - Bearings on the boom extend and retract cables can be greased through access holes in the boom side plates.
 - Number of internal boom parts has been reduced, decreasing service time when rebuilding the machine.
- **New State-of-the-art Control Valve** – Provides smoother operation. The new control valve has specially designed spools to provide optimum control for the smoothest metering and precise load positioning.
- **National Crane Is the Market Leader** – National is number one in the production of commercial truck-mounted boom trucks. National has the resources, programs and people to provide our customers with reliable products.
- **National has the boom truck industry's leading test program.** The Series 1400H is a completely new design that has been through a strenuous six-month testing regimen. Structural parts of the crane have been cycle tested up to 60,000 cycles at full capacity. In addition to cycle testing, each model has been subjected to state-of-the-art strain gauge testing that measures metal deformation as small as one one-millionth of an inch. The net result is that any weak areas are caught in test, not on job sites where costly downtime occurs.
- **Outrigger, lift and telescoping cylinders** are manufactured by National Crane, so that the seals, packing glands, and other cylinder components are traced for accurate shipment of replacement parts.
- **Parts are available for all National Crane machines, even if they are 35 years old.**
- **National has a formalized quality program and is ISO 9001 approved.**
- **You Expect a National Crane to be a Quality Product That Will Provide Years of Service and So Do We.**

- 33-ton (29,94t) maximum capacity
- 167ft (50.91m) maximum vertical reach*
- 137-ft (41.77-m) maximum vertical hydraulic reach*
- Load Moment Indicator system (LMI)
- Proportional boom extension
- High performance planetary winch
- Heavy-duty triple pump hydraulics
- 107-gallon (405L) reservoir with 10-micron return filter
- * Maximum vertical reach is ground-level to boom tip height at maximum extension and angle with outriggers/stabilizers fully extended.

1400H Capacities

Load Rating Chart: Model 14127H with 30-ft jib

Series 1400H Load Rating Charts are available for all Model 14100H and 14127H cranes. National will send you a chart by FAX or mail on request – or you may secure needed load rating information through your nearest National dealer.

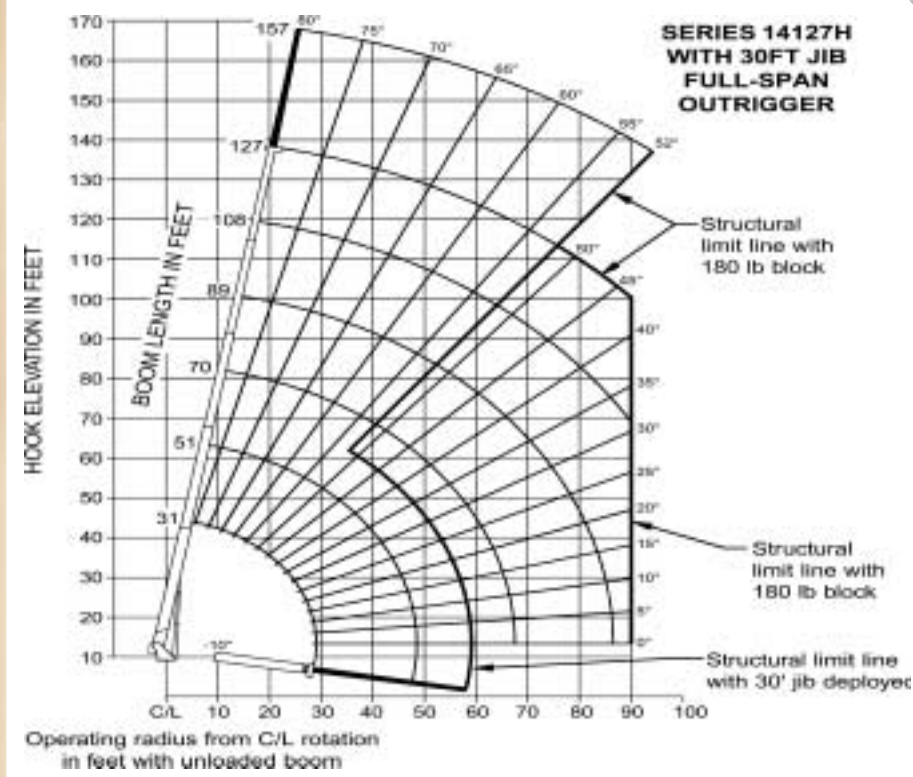

- Caution:**
- Do not operate crane booms, jib extensions, any accessories or loads within 10 ft (3m) of live power lines or other conductors of electricity
 - Jib and boom capacities shown are maximum for each section
 - Do not exceed jib capacities at reduced radii
 - Load ratings shown on the appropriate charts are maximum allowable loads with the crane mounted on a factory-approved truck and all outriggers at either full span or at mid span range and set on a firm level surface so that the crane is level and all tires are suspended
 - Always level the crane with the level indicator located on the crane
 - The operator must reduce loads to allow for factors such as wind, ground conditions, operating speeds and their effects on freely suspended loads
 - Overloading this crane may cause structural collapse or instability
 - Weights of any accessories attached to the boom or loadline must be deducted from the load chart capacities
 - Do not deadhead lineblock against boom tip when extending boom or winching up
 - Keep at least three wraps of loadline on drum at all times
 - Use only specified cable with this machine

LOAD RATINGS

Load Radius (Feet)	Loaded Boom Angle	31 Ft. Boom (Lb)	Loaded Boom Angle	51 Ft. Boom (Lb)	Loaded Boom Angle	70 Ft. Boom (Lb)	Loaded Boom Angle	89 Ft. Boom (Lb)	Loaded Boom Angle	108 Ft. Boom (Lb)	Loaded Boom Angle	127 Ft. Boom (Lb)	
6	79.9	66,000											
8	76.0	47,550											
10	71.9	40,750	79.7	32,700									
12	67.7	35,800	77.4	29,750									
15	61.1	30,200	72.8	25,900	78.1	22,550							
20	49.5	23,950	67.7	20,450	74.8	18,950	78.8	16,600					
25	33.1	17,700	61.2	16,750	70.4	15,350	74.7	14,200	78.1	12,250	80.3	8,200	
30			54.1	14,000	65.9	12,850	72.2	11,850	76.1	10,550	78.5	7,900	
35			46.2	10,550	61.1	10,650	68.6	9,700	73.6	9,050	76.4	7,600	
40			36.5	8,100	55.2	8,350	64.3	8,300	69.8	7,850	73.8	7,200	
45			25.7	6,250	50.9	6,500	61.5	6,700	67.8	6,750	71.5	6,400	
50				45.0	5,100	57.4	5,300	64.6	5,400	69.5	5,500		
55				38.3	4,000	53.2	4,200	61.4	4,300	66.8	4,400		
60				29.8	3,150	48.1	3,300	57.4	3,400	63.6	3,500		
65				19.1	2,400	44.0	2,600	54.6	2,700	61.3	2,800		
70						38.7	2,000	51.1	2,100	58.4	2,150		
75						32.6	1,450	47.3	1,550	55.5	1,650		
80						24.5	1,000	43.2	1,100	52.2	1,200		
85						14.0	650	38.9	750	49.4	800		
90										45.6	500		
	0	12,150	0	4,800	0	2,000	0	500					
	ADD TO CAPACITIES WHEN NO JIB STOWED (lb)		500		300		250		200		150		100

*Shaded areas are structurally limited capacities.

Load Radius (Feet)	Loaded Boom Angle	30 Ft. Jib (Lb)
30	79.9	3,900
35	79.1	3,850
40	77.5	3,700
45	75.9	3,550
50	74.2	3,400
55	72.5	3,250
60	70.7	3,100
65	68.9	2,950
70	66.4	2,600
75	64.4	2,050
80	62.1	1,600
85	59.7	1,200
90	57.3	850
95	54.8	550

LOADLINE EQUIPMENT DEDUCT	
Downhaul weight	... 180 lb
One sheave block	... 375 lb
Two sheave block	... 640 lb
Three sheave block	... 870 lb
Four sheave block	... 970 lb

Mounting Configurations

The mounting configuration shown is based on an 85% stability factor. The complete unit must be installed in accordance with factory requirements and a test performed to determine actual stability and counterweight requirements since individual truck chassis vary. If bare truck weights are not met, counterweight will be required. For 360° stability, front bumper stabilizer (SFO) is required. Chassis must be equipped with front frame suitable for SFO addition. Contact factory for truck specifications. (Specs shown are for 14127H. Contact factory for 14100H details).

Working area	360°
Gross Axle Weight Rating Front	20,000 lb (9072 kg)*
Gross Axle Weight Rating Rear	40,000 lb (18 144 kg)*
Gross Vehicle Weight Rating	60,000 lb (27 216 kg)*
Wheelbase	268 in (681 cm)
Cab to Axle/trunnion (CA/CT)	204 in (518 cm)
After Frame (AF)	120 in (305 cm) minimum
Frame Section Modulus (SM), under crane w/110,000 PSI (758 MPa)	30 in ³ (492 cm ³)
Stability Weight, Front	9,250 lb (4196 kg) minimum**
Stability Weight, Rear	8,100 lb (3674 kg) minimum**
Estimated Average Final Weight	51,500 lb (23 360 kg)**

The diagram shows the 360° working area achieved with the front stabilizer (optional on the Series 1400H). The front stabilizer is required when extending the boom and lifting loads forward of the outriggers. A minimum of 12-in (197 cm²) section modulus at 110,000 psi (759 MPa) is required from the rear of the front spring hanger forward to the front stabilizer. Integral front frame extension required.

- * Required to mount basic crane with 30-ft (9.15-m) jib option. Additional options or heavier bare chassis weights will require additional axles or a GVWR in excess of 60,000 lb (27 216 kg); in some states, special permits for overload are required.
 - ** Estimated axle scale weights prior to installation of crane, stabilizers and subbase for 85% stability.
 - *** Includes basic crane without jib, 100-gal (379-L) of fuel, 22" wood flatbed, hydraulic pump & PTO, rear bumper, rear stabilizer, boom rest and two workers 300lb (136 kg) in cab.
- Note: Chassis will require extended front frame rails for SFO addition.

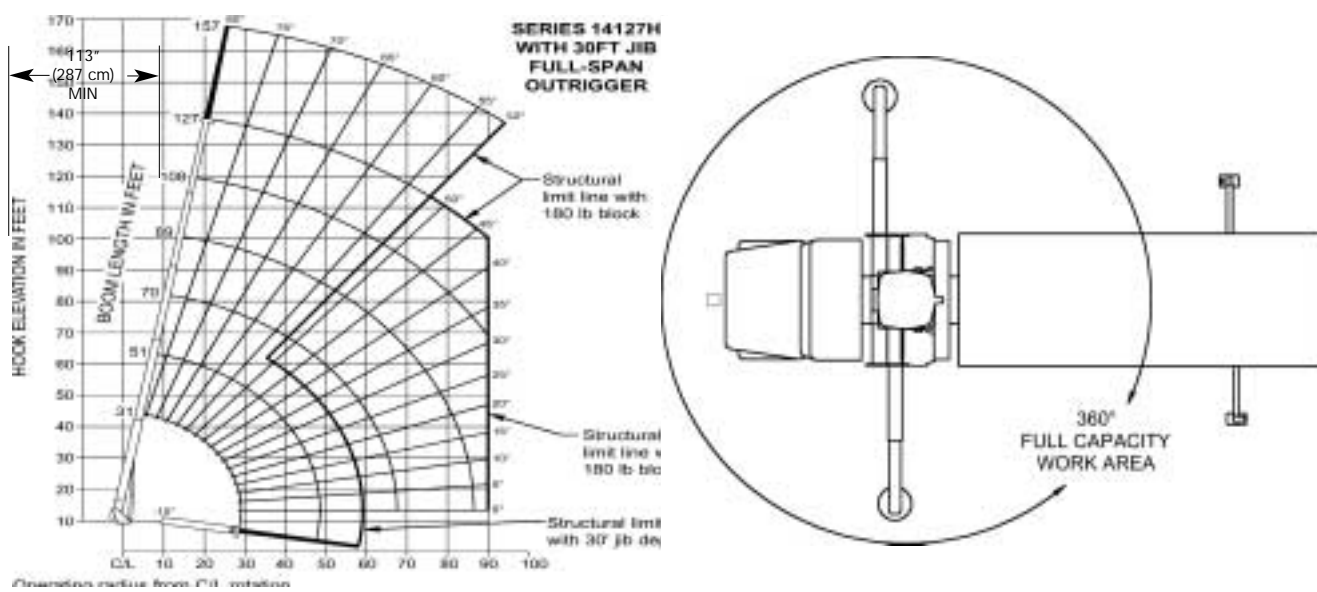

- Notes:**
- Gross Vehicle Weight Rating (GVWR) is dependent on all components of the vehicle (axles, tires, springs, frame, etc.) meeting manufacturers' recommendations; always specify GVWR when purchasing trucks.
 - Diesel engines require a variable speed governor and energize-to-run fuel solenoid for smooth crane operation. Electronic fuel-injected engines are required.
 - All mounting data is based on a National Series 1400H with the standard subbase and an 85 percent stability factor.
 - The complete unit must be installed in accordance with factory requirements, and a test performed to determine actual stability and counterweight requirements per SAE J765; contact the factory for details

*Estimated axle scale weights prior to installation of crane, stabilizers and subbase for 85% stability.