



**NATIONAL
CRANE**

Series **1100**



**product
guide**

features

- 105 ft (32.0 m) Four-Section Boom
- 28 USt (25.4 t) Rating
- "Easy Glide" Wear Pads



contents

Features	2
Mounting Configurations	3
Specifications	4
Capacities	5
Accessories	10
Dimensions Specifications	11



*Product may be shown with optional equipment.



features

Why Buy a National Crane Series 1100?

2



*Product may be shown with optional equipment.

- **28 USt (25.4 t) Rating** – The 1100 provides a 28 USt capacity at a 55 ft radius, an 8% increase in capacity over the Series 900A.
- **105 ft (32.0) Four-section Boom** – The longest in its size range. The long boom allows the operator to perform more lifts without the use of a jib, reducing setup time and improving efficiency.
- **Overload Protection** – All National Crane boom trucks are equipped with overload protection:
 - Load Moment Indicator (LMI) standard on all Series 1100 machines.
 - LMI display and CPU are weatherproof.
 - LCD display is visible in full or low light.
 - All crane load lifting values are displayed simultaneously.
- **“Easy Glide” Boom Wear Pads** – Reduce the conditions that cause boom chatter and vibration. The net result is smoother crane operation.
- **Stronger Torsion Box** – The stronger standard torsion box improves rigidity, reduces truck frame flex and reduces the need for counterweight.
- **Pre-painted Components** – Painting crane components before assembly reduces the possibility of rust, improves serviceability and enhances the appearance of the machine.
- **Electronic versions of manuals available through Manitowoc Crane CARE.**
- **Improved Serviceability** –
 - Bearings on the boom extend and retract cables can be greased through access holes in the boom side plates.
- **State-of-the-art Control Valve** – Provides smoother operation. The new control valve has specially designed spools to provide optimum control for the smoothest metering and precise load positioning.
- **National Crane is the Market Leader** – National Crane is number one in the production of commercial truck-mounted boom trucks and has many programs and people directly and indirectly involved to provide our customers with reliable products.
 - Parts are available for all National Crane machines for the life of the crane.
- **National Crane has the boom truck industry’s leading test program.** Every structural part of the crane is cycle tested, some up to 60,000 cycles at full capacity. In addition to cycle testing, each model is subjected to state-of-the-art strain gauge testing that measures metal deformation as small as one one-millionth of an inch. The net result is that weak areas are caught in test, not on job sites where costly downtime occurs.
- All lift and telescoping cylinders are manufactured by National Crane, so that the seals, packing glands, and end plates are traced for accurate shipment of replacement parts.
- National Crane has a formalized quality program and is ISO 9001 approved.

- 28 USt (25.4 t) maximum capacity
- 161 ft (49.10 m) maximum vertical reach*
- 114 ft (34.75 m) maximum vertical hydraulic reach*
- Load Moment Indicator System (LMI)
- Proportional boom extension
- High performance planetary winch
- Heavy-duty triple pump hydraulics

* Maximum vertical reach is ground-level to boom tip height at maximum extension and angle with outriggers/stabilizers fully extended

1100



mounting configurations

The configurations are based on the Series 1100 with an 85% stability factor. The complete unit must be installed in accordance with factory requirements and a test performed to determine actual stability and counterweight requirements since individual truck chassis vary. Trucks with a frame height in excess of 42-in (107 cm) after mounting will have a final mounted unit height more than 13.5 ft (411.5 cm). Chassis that do not meet these minimum stability weights may require counterweight.

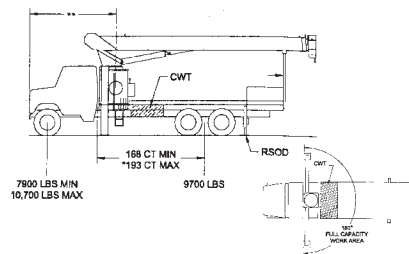

Configuration 1 - 11105

Working area	180°
Gross Axle Weight Rating Front	18,000 lb (8 165 kg)
Gross Axle Weight Rating Rear	34,000 lb (15 422 kg)
Gross Vehicle Weight Rating	52,000 lb (23 587 kg)
Wheelbase	256 in (650 cm)
Cab to Axle/trunnion (CA/CT)	192 in (488 cm)
Frame Section Modulus (SM) under crane w/110,000 PSI (758 MPa)	15.9 in ³ (261 cm ³)
Frame Section Modulus (SM) over rear stabilizers w/110,000 PSI (758 MPa)	13.0 in ³ (213 cm ³)
Stability Weight, Front	7,900 lb (3 583 kg) minimum*
Stability Weight, Rear	9,700 lb (4 400 kg) minimum*
Estimated Average Final Weight	46,300 lb (21 001 kg)

This configuration allows the installation of the Series 11105 by using the subbase for a 22 ft (6.71 m) bed.

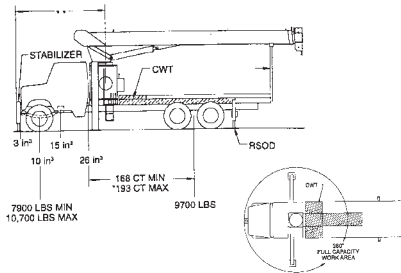

Configuration 2 - 11105 with SFO (Extended front frame axles required for SFO installation.)

Working area	360°
Gross Axle Weight Rating Front	18,000 lb (7 257 kg)
Gross Axle Weight Rating Rear	34,000 lb (15 422 kg)
Gross Vehicle Weight Rating	52,000 lb (23 587 kg)
Wheelbase	256 in (650 cm)
Cab to Axle/trunnion (CA/CT)	192 in (488 cm)
Frame Section Modulus (SM) under crane w/110,000 PSI (758 MPa)	26.0 in ³ (426 cm ³)
Frame Section Modulus (SM) over rear stabilizers w/110,000 PSI (758 MPa)	15.0 in ³ (245 cm ³)
Stability Weight, Front	7,900 lb (3 583 kg) minimum*
Stability Weight, Rear	9,700 lb (4 400 kg) minimum*
Estimated Average Final Weight	46,300 lb (21 001 kg)

This mount requires front stabilizer for full capacity 360° around the truck. Front stabilizer gives the machine a solid base, helping the operator control loads precisely. This configuration requires a 22 ft (6.71 m) bed.

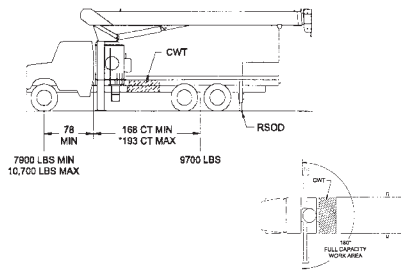

Configuration 3 - 1195 / 1169

Working area	180°
Gross Axle Weight Rating Front	18,000 lb (8 165 kg)
Gross Axle Weight Rating Rear	34,000 lb (15 422 kg)
Gross Vehicle Weight Rating	52,000 lb (23 587 kg)
Wheelbase	246 in (625 cm)
Cab to Axle/trunnion (CA/CT)	168 in (427 cm)
Frame Section Modulus (SM) under crane w/110,000 PSI (758 MPa)	15.9 in ³ (261 cm ³)
Frame Section Modulus (SM) over rear stabilizers w/110,000 PSI (758 MPa)	13.0 in ³ (213 cm ³)
Stability Weight, Front	7,900 lb (3 583 kg) minimum*
Stability Weight, Rear	9,700 lb (4 400 kg) minimum*
Estimated Average Final Weight	44,800 lb (20 321 kg)

This configuration allows the installation of the Series 1195 or 1169 on a chassis with a small frame by using a subbase for a 20 ft (6.10 m) bed or a different subbase for a 22 ft (6.71 m) bed.

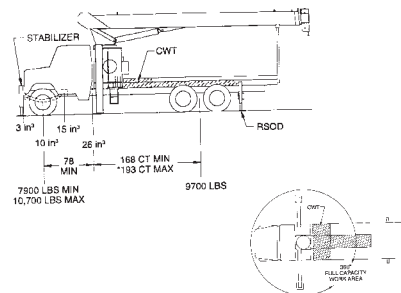

Configuration 4 - 1195 / 1169 with SFO (Extended front frame axles required for SFO installation.)

Working area	360°
Gross Axle Weight Rating Front	18,000 lb (8 165 kg)
Gross Axle Weight Rating Rear	34,000 lb (15 422 kg)
Gross Vehicle Weight Rating	52,000 lb (23 587 kg)
Wheelbase	246 in (625 cm)
Cab to Axle/trunnion (CA/CT)	168 in (427 cm)
Frame Section Modulus (SM) under crane w/110,000 PSI (758 MPa)	26.0 in ³ (426 cm ³)
Frame Section Modulus (SM) over rear stabilizers w/110,000 PSI (758 MPa)	13.0 in ³ (213 cm ³)
Stability Weight, Front	7,900 lb (3 583 kg) minimum*
Stability Weight, Rear	9,700 lb (4 400 kg) minimum*
Estimated Average Final Weight	44,800 lb (20 321 kg)

This configuration allows the installation of the 1195 or 1169 on a chassis by using a subbase for a 20 ft (6.10 m) bed or a different subbase for a 22 ft (6.71 m) bed. This mount requires front stabilizer for full capacity 360° around the truck. Front stabilizer gives the machine a solid base, helping the operator control loads.

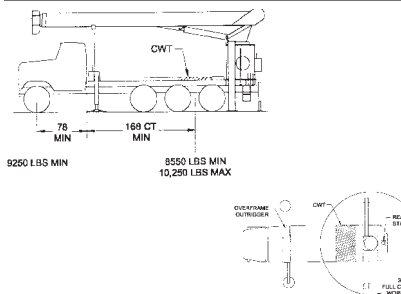

Configuration 5 - Rear Mount

Working area	360°
Gross Axle Weight Rating Front	16,000 lb (7 257 kg)
Gross Axle Weight Rating Rear	40,000 lb (18 143 kg)
Gross Vehicle Weight Rating	56,000 lb (25 401 kg)
Wheelbase	246 in (625 cm)
Cab to Axle/trunnion (CA/CT)	168 in (427 cm)
Frame Section Modulus (SM) under crane w/110,000 PSI (758 MPa)	15.9 in ³ (261 cm ³)
Frame Section Modulus (SM) over rear stabilizers w/110,000 PSI (758 MPa)	15.9 in ³ (261 cm ³)
Stability Weight, Front	9,250 lb (4 196 kg) minimum*
Stability Weight, Rear	8,550 lb (3 878 kg) minimum*
Estimated Average Final Weight	48,000 lb (21 772 kg)

This configuration allows the rear-mount installation of the Series 1100. This configuration is 360° stable and allows the effective use of close working area to lift the heavier capacity loads. maximum bed length is 16 ft (4.87 m).

Notes:

- Gross Vehicle Weight rating (GVWR) is dependent on all components of the vehicle (axles, tires, springs, frame, etc.) meeting manufacturers' recommendations; always specify GVWR when purchasing trucks
- Diesel engines require a variable speed governor and energize-to-run fuel solenoid for smooth crane operation; electronic fuel injection requires EET engine remote throttle

- All mounting data is based on a National Series 1100 with an 85% stability factor
- The complete unit must be installed in accordance with factory requirements, and a test performed to determine actual stability and counterweight requirements per SAE J765; contact the factory for details
- Transmission neutral safety interlock switch is required with optional remote control

*Estimated axle scale weights prior to installation of crane, stabilizers and subbase for 85% stability.

**If the distance from the front bumper (SFO) to center of rotation exceeds 144 in (366 cm), the 40 ft (12.19 m) overall truck length restriction will be exceeded. Overall length restrictions vary from state to state. In some states it is legal to be more than 40 ft (12.18 m) in length, and some states allow overlength permits.

3**1100**



specifications

Boom and Jib Combinations Data

Available in three basic models: 1169 three-section, 1195 four-section and 11105 four-section

4

Model 1169 — Equipped with a 27.5 ft - 69 ft (8.38-21.04 m) three-section boom. Maximum tip height is 79 ft (24.08 m).

27.5-69 ft (8.38-21.04 m) three-section boom



Model 1195 — Equipped with a 28-95 ft (8.53-28.96 m) four-section boom. This model can be equipped with a 25-44 ft (7.62-13.41 m) manual pull-out jib. Maximum tip height w/ 44 ft (13.41 m) jib is 147 ft (44.81 m).

28-95 ft (8.54-28.96 m) four-section boom **11FJ44M** 25-44 ft (7.62-13.41 m) manual pull-out jib



Model 11105 — Equipped with a 31 ft to 105 ft (9.44-32.01 m) four-section boom. This model can be equipped with a 25-44 ft (7.62-13.41 m) manual pull-out jib. Maximum tip height w/ 44 ft (13.41 m) jib is 157 ft.

31-105 ft (9.45-32.01 m) four-section boom **11FJ44M** 25-44 ft (7.62-13.41 m) manual pull-out jib



Note: Maximum tip is measured with outriggers/stabilizers fully extended.

1100 Winch Data

- All winch pulls and speeds in this chart are shown on the fourth layer
- Winch line pulls would increase on the first, second and third layers
- Winch line speed would decrease on the first, second and third layers
- Winch line pulls may be limited by the winch capacity or the ANSI 5 to 1 cable safety factor
- Hook blocks are rated at maximum capacity for the block. **Do not exceed rated cable pull with any block.**

Winch	Cable Supplied	Average Breaking Strength	1 Part Line	2 Part Line	3 Part Line	4 Part Line	5 Part Line	6 Part Line	7 Part Line
			Lift and Speed	Lift and Speed	Lift and Speed	Lift and Speed	Lift and Speed	Lift and Speed	Lift and Speed
Standard Planetary Winch	9/16 in Diameter Rotation Resistant	38,500 lb (17,463 kg)	7,700 lb (3,492 kg) 164 fpm (50 m/min)	15,400 lb (6,985 kg) 82 fpm (25 m/min)	23,100 lb (10,477 kg) 55 fpm (17 m/min)	30,800 lb (13,970 kg) 41 fpm (13 m/min)	38,500 lb (17,463 kg) 33 fpm (10 m/min)	46,200 lb (20,955 kg) 27 fpm (8 m/min)	53,900 lb (24,449 kg)* 23 fpm (7 m/min)
With "Burst-of-Speed"	Same as corresponding cable data shown above		3,000 lb (1,361 kg) 265 fpm (81 m/min)	6,000 lb (2,722 kg) 133 fpm (41 m/min)	9,000 lb (4,082 kg) 88 fpm (27 m/min)	12,000 lb (5,443 kg) 66 fpm (20 m/min)	15,000 lb (6,803 kg) 53 fpm (16 m/min)	18,000 lb (8,164 kg) 44 fpm (13 m/min)	21,000 lb (9,525 kg) 37 fpm (11 m/min)

Winch	Bare Drum Pull	Allowable Cable Pull
With standard rotation resistant rope	10,000 lb (4,536 kg)	7,700 lb (3,493 kg)

NOTE: 56,000 lb (25.4 t) LOAD REQUIRES OPTIONAL 9/16 in 6x25 IWRC CABLE.

Block Type	Rating	Weight
Downhaul Weight	3.85 USt (3.49 t)	150 lb (68 kg)
1 Sheave Block	11.55 USt (10.48 t)	305 lb (138 kg)
2 Sheave Block	19.25 USt (17.46 t)	355 lb (161 kg)
3 Sheave Block	28.0 USt (25.40 t)	690 lb (313 kg)

1100



capacities

5

Load Rating Chart: Series 1169 (21.04 m) Boom

National Crane will send you a chart on request – or you may secure needed load rating information through your nearest National Crane dealer.

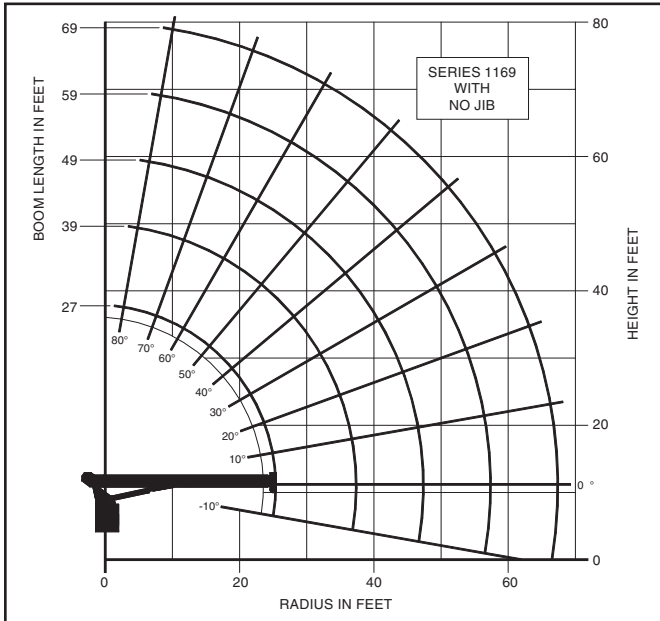

Caution:

- Do not operate crane booms, jib extensions, any accessories or loads within 10 ft (3m) of live power lines or other conductors of electricity
- Jib and boom capacities shown are maximum for each section
- Do not exceed capacities at reduced radii
- Load ratings shown on the load rating charts are maximum allowable loads with the outriggers properly extended on a firm, level surface and the crane leveled and mounted on a factory-recommended truck
- Always level the crane with the level indicator located on the crane
- The operator must reduce loads to allow for factors such as wind, ground conditions, operating speeds and their effects on freely suspended loads
- Overloading this crane may cause structural collapse or instability
- Weights of any accessories attached to the boom or loadline must be deducted from the load chart capacities
- Do not exceed jib capacities at any reduced boom lengths
- Do not deadhead lineblock against boom tip when extending boom or winching up
- Keep at least three wraps of loadline on drum at all times
- Use only specified cable with this machine
- Maximum capacity with Burst-of-Speed is 3,000 lb (1 361 kg) on single part line

**SERIES 1169
NO JIB**

LOADLINE EQUIPMENT DEDUCT

- Downhaul weight.....150 lb (68 kg)
- One sheave block305 lb (138 kg)
- Two sheave block.....355 lb (161 kg)
- Three sheave block.....575 lb (261 kg)

Load Rating Chart: Series 1169 (21.04 m) Boom

LOAD RADIUS (ft)	LOADED BOOM ANGLE	27 ft BOOM (lb)	LOADED BOOM ANGLE	39 ft BOOM (lb)	LOADED BOOM ANGLE	49 ft BOOM (lb)	LOADED BOOM ANGLE	59 ft BOOM (lb)	LOADED BOOM ANGLE	69 ft BOOM (lb)
5	77	*53,900								
8	70	42,000								
10	65.5	35,400								
12	60.5	30,700	71	28,300	75.5	26,500	78.5	25,000		
14	55	26,900	67.5	24,900	73	23,400	76	22,000	79.5	19,500
16	49.5	23,900	64	22,400	70	20,900	74	19,700	78	18,500
20	36.5	18,800	57.5	18,300	65	17,400	70	16,200	74.5	15,800
25			48	14,800	58	14,200	65	13,300	70	12,700
30			36	12,000	51	11,900	59	11,200	65	10,800
35			19	8,800	42.5	10,000	53	9,600	60	9,300
40					33.5	8,000	46	8,100	56	8,200
45					19	6,500	39.5	6,700	50	7,000
50							31	5,600	44	5,900
55							18	4,700	37	5,000
60									29	4,350
65									17	3,500
	0	8,500	0	5,100	0	3,500	0	2,400	0	1,700

NOTE: 56,000 lb (25.4 t) LOAD REQUIRES OPTIONAL 9/16 in 6x25 IWRC CABLE.

Shaded areas are structurally limited capacities.

THIS CHART IS ONLY A GUIDE AND SHOULD NOT BE USED TO OPERATE THE CRANE. The individual crane's load chart, operating instructions and other instructional plates must be read and understood prior to operating the crane.

1100



capacities

Load Rating Chart: Series 1195 (28.96 m) Boom with 44 ft (13.41 m) Jib

National Crane will send you a chart on request – or you may secure needed load rating information through your nearest National Crane dealer.

6

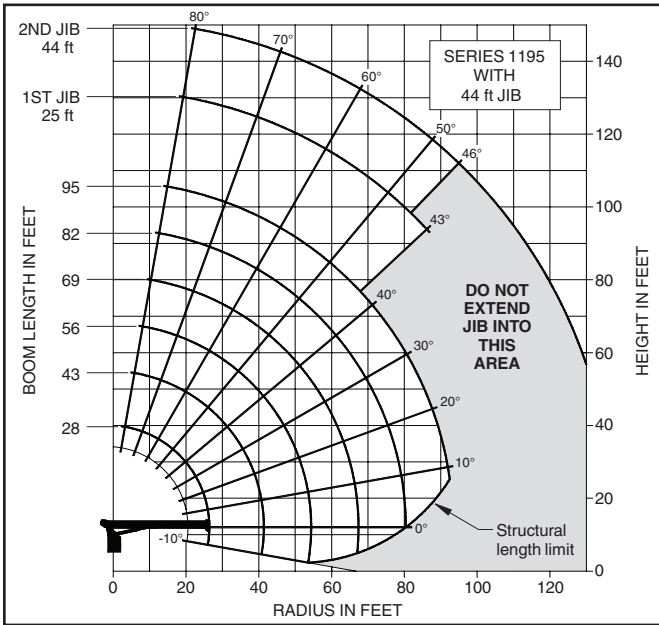

Caution:

- Do not operate crane booms, jib extensions, any accessories or loads within 10 ft (3m) of live power lines or other conductors of electricity
- Jib and boom capacities shown are maximum for each section
- Do not exceed capacities at reduced radii
- Load ratings shown on the load rating charts are maximum allowable loads with the outriggers properly extended on a firm, level surface and the crane leveled and mounted on a factory-recommended truck
- Always level the crane with the level indicator located on the crane
- The operator must reduce loads to allow for factors such as wind, ground conditions, operating speeds and their effects on freely suspended loads
- Overloading this crane may cause structural collapse or instability
- Weights of any accessories attached to the boom or loadline must be deducted from the load chart capacities
- Do not exceed jib capacities at any reduced boom lengths
- Do not deadhead lineblock against boom tip when extending boom or winching up
- Keep at least three wraps of loadline on drum at all times
- Use only specified cable with this machine
- Maximum capacity with Burst-of-Speed is 3,000 lb (1 361 kg) on single part line

SERIES 1195 WITH 44 ft JIB

NOTE:

1. Operate with jib by radius when main boom is fully extended. If necessary increase boom angle to maintain loaded radius.
2. Operate with jib by boom angle when main boom is not fully extended. Do not exceed rated jib capacities at any reduced boom lengths.

LOADLINE EQUIPMENT DEDUCT

- Downhaul weight.....150 lb (68 kg)
- One sheave block.....305 lb (138 kg)
- Two sheave block.....355 lb (161 kg)
- Three sheave block.....575 lb (261 kg)

Load Rating Chart: Series 1195 (28.96 m) Boom with 44' (13.41 m) Jib

LOAD RADIUS (ft)	LOADED BOOM ANGLE	28 ft BOOM (lb)	LOADED BOOM ANGLE	43 ft BOOM (lb)	LOADED BOOM ANGLE	56 ft BOOM (lb)	LOADED BOOM ANGLE	69 ft BOOM (lb)	LOADED BOOM ANGLE	82 ft BOOM (lb)	LOADED BOOM ANGLE	95 ft BOOM (lb)
5	78.5	*53,900										
8	71.5	39,700										
10	67	33,100	76	30,100								
12	62.5	28,300	73.5	25,800	78	23,700						
14	57.5	24,800	70.5	22,600	76	20,700	79	18,700				
16	52	21,800	67.5	20,000	73.5	18,400	77.5	16,700	80	14,300		
20	40	17,100	61.5	16,300	69	15,000	74	13,600	77	12,300	79	10,000
25	17.5	11,200	53	13,100	63.5	12,100	69.5	11,100	73.5	10,300	76	8,800
30			43.5	10,600	57.5	10,100	65	9,300	69.5	8,700	73	7,800
35			32	8,400	50.5	8,500	60	7,900	66	7,300	70	6,800
40			15.5	5,800	44	7,200	55	6,800	62	6,400	66.5	5,900
45					35.5	5,800	50	5,650	58	5,450	63	5,100
50					24.5	4,600	43.5	4,650	53.5	4,550	59.5	4,400
55							37	3,800	48.5	3,800	56	3,800
60							28.5	3,050	43.5	3,200	52	3,200
65							16.5	2,300	37.5	2,600	47.5	2,650
70									31	2,100	43	2,150
75									22.5	1,700	38	1,750
80											32.5	1,350
85											26	1,050
90											16.5	750
	0	5,600	0	2,500	0	1,150	0	350				
ADD TO CAPACITIES WHEN NO JIB STOWED (lb)		600		400		300		300		200		200

LOAD RADIUS (ft)	LOADED BOOM ANGLE	25 ft JIB (lb)	LOADED BOOM ANGLE	44 ft JIB (lb)
30	77	5,200	79.5	3,200
35	75	4,800	78	3,050
40	72.5	4,350	76	2,850
45	70	3,900	74	2,650
50	67.5	3,500	72	2,450
55	65	3,050	70	2,300
60	62	2,550	67	2,150
65	59	2,100	65	2,000
70	56	1,750	63	1,850
75	52.5	1,400	60.5	1,600
80	49.5	1,100	58	1,350
85	46	800	54.5	1,150
90	43	600	52	950
95			49	750
100			46	600

NOTE: 56,000 lb (25.4 t) LOAD REQUIRES OPTIONAL 9/16 in 6x25 IWRC CABLE.

Shaded areas are structurally limited capacities.

THIS CHART IS ONLY A GUIDE AND SHOULD NOT BE USED TO OPERATE THE CRANE. The individual crane's load chart, operating instructions and other instructional plates must be read and understood prior to operating the crane.

1100



capacities

Load Rating Chart: Series 1195 (28.96 m) Boom

National Crane will send you a chart on request – or you may secure needed load rating information through your nearest National Crane dealer.

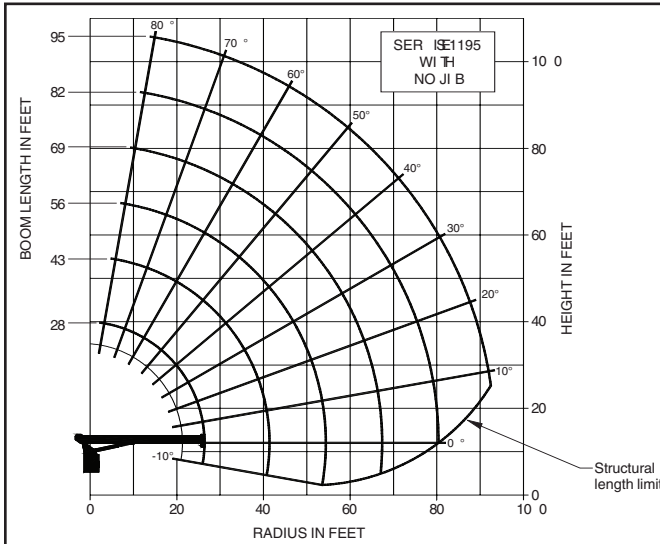

Caution:

- Do not operate crane booms, jib extensions, any accessories or loads within 10 ft (3m) of live power lines or other conductors of electricity
- Jib and boom capacities shown are maximum for each section
- Do not exceed capacities at reduced radii
- Load ratings shown on the load rating charts are maximum allowable loads with the outriggers properly extended on a firm, level surface and the crane leveled and mounted on a factory-recommended truck
- Always level the crane with the level indicator located on the crane
- The operator must reduce loads to allow for factors such as wind, ground conditions, operating speeds and their effects on freely suspended loads
- Overloading this crane may cause structural collapse or instability
- Weights of any accessories attached to the boom or loadline must be deducted from the load chart capacities
- Do not exceed jib capacities at any reduced boom lengths
- Do not deadhead lineblock against boom tip when extending boom or winching up
- Keep at least three wraps of loadline on drum at all times
- Use only specified cable with this machine
- Maximum capacity with Burst-of-Speed is 3,000 lb (1 361 kg) on single part line

7

**SERIES 1195
NO JIB**

LOADLINE EQUIPMENT DEDUCT

- Downhaul weight.....150 lb (68 kg)
- One sheave block305 lb (138 kg)
- Two sheave block.....355 lb (161 kg)
- Three sheave block.....575 lb (261 kg)

Load Rating Chart: Series 1195 (28.96 m) Boom

LOAD RADIUS (ft)	LOADED BOOM ANGLE	28 ft BOOM (lb)	LOADED BOOM ANGLE	43 ft BOOM (lb)	LOADED BOOM ANGLE	56 ft BOOM (lb)	LOADED BOOM ANGLE	69 ft BOOM (lb)	LOADED BOOM ANGLE	82 ft BOOM (lb)	LOADED BOOM ANGLE	95 ft BOOM (lb)
5	78.5	*53,900										
8	71.5	40,300										
10	67	33,700	76	30,500								
12	62.5	28,900	73.5	26,200	78	24,000						
14	57.5	25,400	70.5	23,000	76	21,000	79	19,000				
16	52	22,400	67.5	20,400	73.5	18,700	77.5	17,000	80	14,500		
20	40	17,700	61.5	16,700	69	15,300	74	13,900	77	12,500	79	10,200
25	17.5	11,800	53	13,500	63.5	12,400	69.5	11,400	73.5	10,500	76	9,000
30			43.5	11,000	57.5	10,400	65	9,600	69.5	8,900	73	8,000
35			32	8,800	50.5	8,800	60	8,200	66	7,500	70	7,000
40			15.5	6,200	44	7,500	55	7,100	62	6,600	66.5	6,100
45					35.5	6,100	50	5,950	58	5,650	63	5,300
50					24.5	4,900	43.5	4,950	53.5	4,750	59.5	4,600
55							37	4,100	48.5	4,000	56	4,000
60							28.5	3,350	43.5	3,400	52	3,400
65							16.5	2,600	37.5	2,800	47.5	2,850
70									31	2,300	43	2,350
75									22.5	1,900	38	1,950
80											32.5	1,550
85											26	1,250
90											16.5	950
	0	6,200	0	2,900	0	1,450	0	650				

NOTE: 56,000 lb (25.4 t) LOAD REQUIRES OPTIONAL 9/16 in 6x25 IWRC CABLE.

Shaded areas are structurally limited capacities.

THIS CHART IS ONLY A GUIDE AND SHOULD NOT BE USED TO OPERATE THE CRANE. The individual crane's load chart, operating instructions and other instructional plates must be read and understood prior to operating the crane.

1100



capacities

Load Rating Chart: Series 11105 (32.0 m) Boom with 44 ft (13.41 m) Jib

National Crane will send you a chart on request – or you may secure needed load rating information through your nearest National Crane dealer.

8

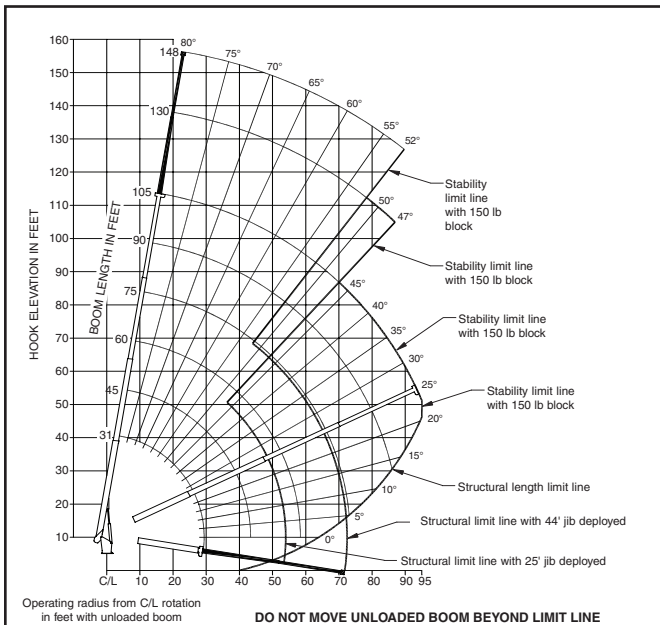

Caution:

- Do not operate crane booms, jib extensions, any accessories or loads within 10 ft (3m) of live power lines or other conductors of electricity
- Jib and boom capacities shown are maximum for each section
- Do not exceed capacities at reduced radii
- Load ratings shown on the load rating charts are maximum allowable loads with the outriggers properly extended on a firm, level surface and the crane leveled and mounted on a factory-recommended truck
- Always level the crane with the level indicator located on the crane
- The operator must reduce loads to allow for factors such as wind, ground conditions, operating speeds and their effects on freely suspended loads
- Overloading this crane may cause structural collapse or instability
- Weights of any accessories attached to the boom or loadline must be deducted from the load chart capacities
- Do not exceed jib capacities at any reduced boom lengths
- Do not deadhead lineblock against boom tip when extending boom or winching up
- Keep at least three wraps of loadline on drum at all times
- Use only specified cable with this machine
- Maximum capacity with Burst-of-Speed is 3,000 lb (1 361 kg) on single part line

**SERIES 11105
WITH
44 ft JIB**

NOTE:

1. Operate with jib by radius when main boom is fully extended. If necessary increase boom angle to maintain loaded radius.
2. Operate with jib by boom angle when main boom is not fully extended. Do not exceed rated jib capacities at any reduced boom lengths.

LOADLINE EQUIPMENT DEDUCT

Downhaul weight.....	150 lb (68 kg)
One sheave block.....	305 lb (138 kg)
Two sheave block.....	355 lb (161 kg)
Three sheave block.....	575 lb (261 kg)

Load Rating Chart: Series 11105 (32.0 m) Boom with 44 ft (13.41 m) Jib

LOAD RADIUS (ft)	LOADED BOOM ANGLE	31 ft BOOM (lb)	LOADED BOOM ANGLE	45 ft BOOM (lb)	LOADED BOOM ANGLE	60 ft BOOM (lb)	LOADED BOOM ANGLE	75 ft BOOM (lb)	LOADED BOOM ANGLE	90 ft BOOM (lb)	LOADED BOOM ANGLE	105 ft BOOM (lb)
5	79.4	53,900										
8	73.1	37,550	79.3	29,400								
10	68.9	30,950	76.8	28,500								
12	64.6	26,450	74	24,200	78.8	21,850						
14	60.2	22,850	71.2	21,100	76.8	19,050	80	15,050				
16	55.6	20,150	68.4	18,600	74.8	16,850	78.5	14,650				
20	45.5	15,850	62.6	15,000	70.7	13,650	75.4	12,250	78.4	10,500	80.2	7,450
25	29.1	11,350	54.8	11,900	65.4	10,850	71.3	9,850	75.1	8,700	77.8	7,050
30			46.3	9,600	59.8	8,950	67.1	8,150	71.8	7,500	75	6,250
35			36.1	7,600	53.9	7,500	63.1	6,700	68.6	6,200	72.2	5,450
40			23.5	5,500	48	6,150	58.6	5,750	65	5,250	69.3	4,750
45					40.8	5,100	53.8	4,900	61.3	4,500	66.2	4,050
50					32.2	4,100	48.7	4,200	57.5	3,900	63.1	3,550
55					20.6	2,850	43	3,550	53.5	3,400	60	3,150
60							36.7	2,900	49.2	2,900	56.6	2,700
65							29.1	2,300	44.6	2,450	53.2	2,400
70							18.7	1,450	39.4	1,900	49.5	2,050
75									33.6	1,500	45.5	1,600
80									26.8	1,100	41.2	1,200
85									17.2	500	36.5	900
90											31.2	600
95											24.8	350
0		4,350	0	1,800	0	450						
ADD TO CAPACITIES WHEN NO JIB STOWED (lb)		850		600		450		350		300		250

LOAD RADIUS (ft)	LOADED BOOM ANGLE	25 ft JIB (lb)	LOADED BOOM ANGLE	44 ft JIB (lb)
30	78.3	4,200		
35	76.2	3,800	78.2	2,400
40	74	3,400	76.4	2,250
45	71.7	2,900	74.7	2,150
50	69.4	2,500	72.8	2,000
55	66.9	2,100	70.8	1,800
60	64.5	1,800	68.9	1,650
65	61.9	1,500	66.8	1,450
70	59.4	1,300	64.6	1,300
75	56.7	1,100	62.4	1,100
80	53.9	900	60	900
85	51	700	57.8	800
90	47.9	500	55.4	700
95			52.9	550

NOTE: 56,000 lb (25.4 t) LOAD REQUIRES OPTIONAL 9/16 in 6x25 IWRC CABLE.

Shaded areas are structurally limited capacities.

THIS CHART IS ONLY A GUIDE AND SHOULD NOT BE USED TO OPERATE THE CRANE. The individual crane's load chart, operating instructions and other instructional plates must be read and understood prior to operating the crane.

1100



capacities

Load Rating Chart: Series 11105 (32.0 m) Boom

National Crane will send you a chart on request – or you may secure needed load rating information through your nearest National Crane dealer.

9

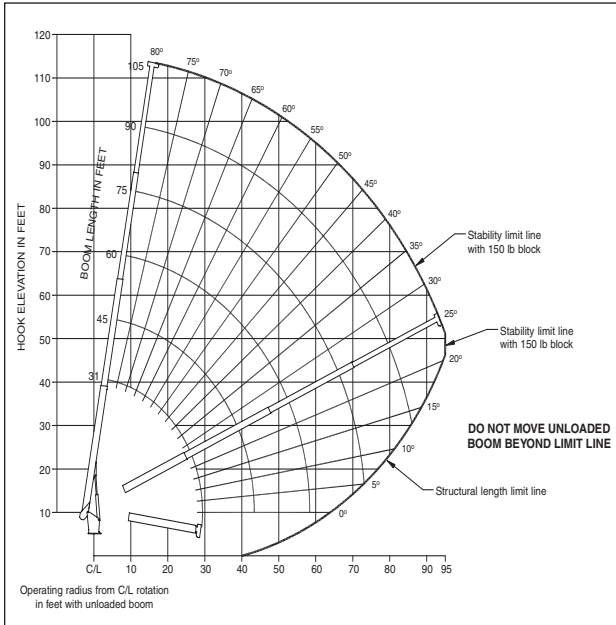

CAUTION:

- Do not operate crane booms, jib extensions, any accessories or loads within 10 ft (3m) of live power lines or other conductors of electricity.
- Jib and boom capacities shown are maximum for each section.
- Do not exceed capacities at reduced radii
- Load ratings shown on the load rating charts are maximum allowable loads with the outriggers properly extended on a firm, level surface and the crane leveled and mounted on a factory recommended truck.
- Always level the crane with the level indicator located on the crane.
- The operator must reduce load to allow for factors such as wind, ground conditions, operating speeds and their effects on freely suspended loads.
- Overloading this crane may cause structural collapse or instability.
- Weights on any accessories attached to the boom or loadline must be deducted from the load chart capacities.
- Do not exceed jib capabilities at any reduced boom lengths.
- Do not deadhead lineblock against boom tip when extending boom or winching up.
- Keep at least three wraps of loadline on drum at all times.
- Use only specified cable with this machine.

**SERIES 11105
NO JIB**

LOADLINE EQUIPMENT DEDUCT	
Downhaul weight.....	150 lb (68 kg)
One sheave block	305 lb (138 kg)
Two sheave block.....	355 lb (161 kg)
Three sheave block.....	575 lb (261 kg)

Load Rating Chart: Series 11105 (32.0 m) Boom

LOAD RADIUS (ft)	LOADED BOOM ANGLE	31 ft BOOM (lb)	LOADED BOOM ANGLE	45 ft BOOM (lb)	LOADED BOOM ANGLE	60 ft BOOM (lb)	LOADED BOOM ANGLE	75 ft BOOM (lb)	LOADED BOOM ANGLE	90 ft BOOM (lb)	LOADED BOOM ANGLE	105 ft BOOM (lb)
5	79.4	*53,900										
8	73.1	38,400	79.3	30,000								
10	68.9	31,800	76.8	29,100								
12	64.6	27,300	74	24,800	78.8	22,300						
14	60.2	23,700	71.2	21,700	76.8	19,500	80	15,400				
16	55.6	21,000	68.4	19,200	74.8	17,300	78.5	15,000				
20	45.5	16,700	62.6	15,600	70.7	14,100	75.4	12,600	78.4	10,800	80.2	7,700
25	29.1	12,200	54.8	12,500	65.4	11,300	71.3	10,200	75.1	9,000	77.8	7,300
30			46.3	10,200	59.8	9,400	67.1	8,500	71.8	7,800	75	6,500
35			36.1	8,200	53.9	7,950	63.1	7,050	68.6	6,500	72.2	5,700
40			23.5	6,100	48	6,600	58.6	6,100	65	5,550	69.3	5,000
45					40.8	5,550	53.8	5,250	61.3	4,800	66.2	4,300
50					32.2	4,550	48.7	4,550	57.5	4,200	63.1	3,800
55					20.6	3,300	43	3,900	53.5	3,700	60	3,400
60							36.7	3,250	49.2	3,200	56.6	2,950
65							29.1	2,650	44.6	2,750	53.2	2,650
70							18.7	1,800	39.4	2,200	49.5	2,300
75									33.6	1,800	45.5	1,850
80									26.8	1,400	41.2	1,450
85									17.2	800	36.5	1,150
90											31.2	850
95											24.8	600
	0	5,200	0	2,400	0	900						

NOTE: 56,000 lb (25.4 t) LOAD REQUIRES OPTIONAL 9/16 in 6x25 IWRC CABLE.

Shaded areas are structurally limited capacities.

THIS CHART IS ONLY A GUIDE AND SHOULD NOT BE USED TO OPERATE THE CRANE. The individual crane's load chart, operating instructions and other instructional plates must be read and understood prior to operating the crane.

1100



accessories

10

Radio Remote Controls –

Eliminate the handling and maintenance concerns that accompany cabled remotes. Operate to a range of about 250 ft (76 m), varying with conditions.

• **NB4R**

One-Person Basket –

Strong but lightweight steel basket with 300 lb (139 kg) capacity, gravity hung with swing lock and full body harness.

• **B1-S**
• **2B1-S** (for dual locking baskets)

Heavy-duty Personnel Basket –

1,200 lb. (544 kg) capacity steel basket with safety loops for four passengers. Gravity leveling 72 x 42 in (183 x 107 cm) platform. Fast attachment and secure locking systems. Load chart must show 2,300 lb (1 043 kg) minimum to operate this accessory.

• **BSA-1**
• **BSA-R1** (provides rotation)

Hydraulic Oil Cooler –

Automatic, self-contained radiator system with electric fans cools oil under continuous operation.

• **OC**

Outrigger Motion Alarms –

Available for “A” frame O/R and ASH stabilizers.
Available for HO outriggers and RSO stabilizers.

• **OMA-1**
• **OMA-2**

Hour Meter –

Hour meter in truck cab to record crane operation hours.

• **HRM**

Bulkhead Option –

Steel 30 in solid wall bulkhead for all flatbeds.

• **BHSD**

Steel Tool Box Options

**Spanish-Language Danger Decals, Control Knobs,
and Operators’ Manuals**

• **SDD**
• **SOM**

1100



dimensions specifications

Dimensions Specifications

MODEL 1155 28'-3" RETRACTED 95' EXTENDED (8.61 m - 28.96 m)
MODEL 1169 27' RETRACTED 69' EXTENDED (8.23 m - 21.03 m)

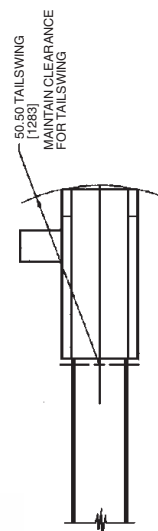
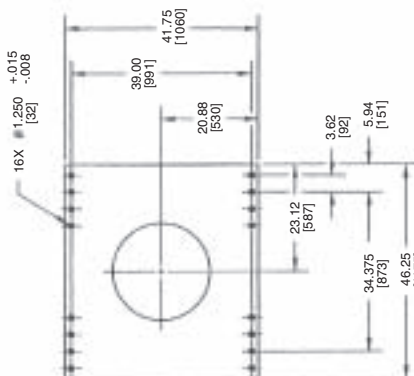
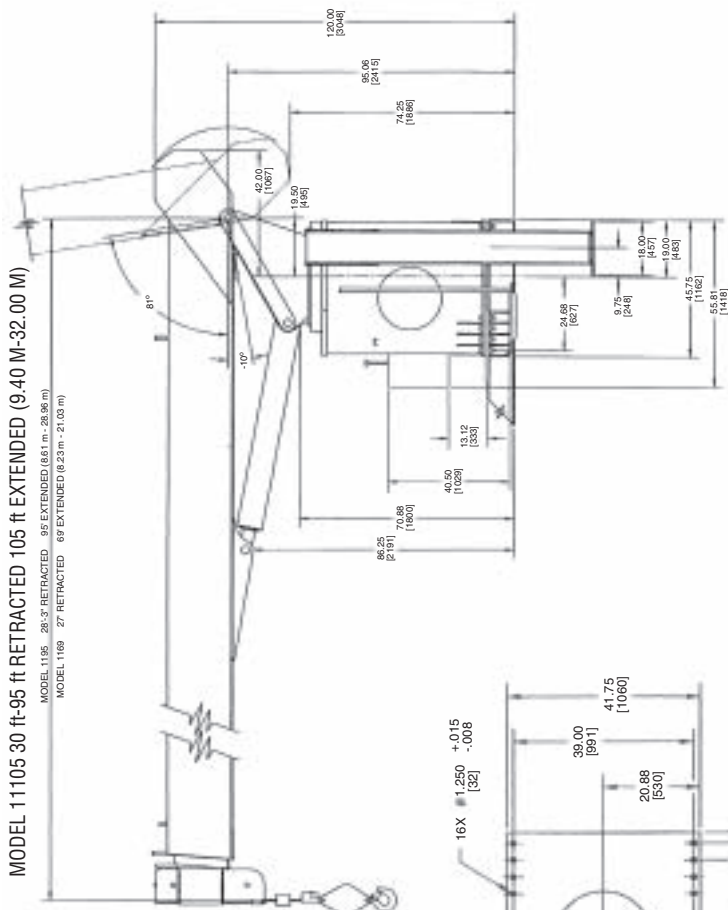

Mount	Series	G in (mm)	DRY WEIGHT lb (kg)	WITH OIL/WT lb (kg)
Std	1169	96 (2438)	19600 (8890)	20400 (9253)
Rear	1169	114 (2896)	23150 (10500)	23950 (10864)
Std	1195	98 (2489)	20800 (9434)	21600 (9798)
Rear	1195	117 (2972)	24350 (11045)	25150 (11408)
Std	11105	100 (2540)	21640 (9816)	22480 (10197)
Rear	11105	119 (3023)	25190 (11426)	25990 (11789)

*Weight includes all items except RSOD (1400 lb). Boom fully retracted
 **Weight includes all items including complete HO and SRO. Boom fully retracted.

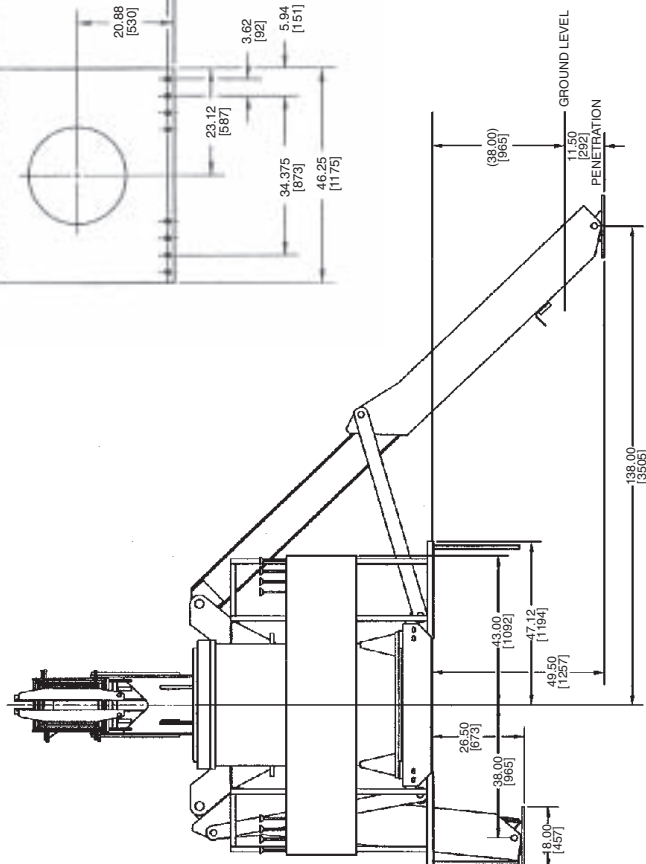



Regional Headquarters

Americas

Manitowoc, Wisconsin, USA

Tel: +1 920 684 6621
Fax: +1 920 683 6278

Shady Grove, Pennsylvania, USA

Tel: +1 717 597 8121
Fax: +1 717 597 4062

Regional Offices

Americas

Brazil

Alphaville

Tel: +55 11 4688 2716
Fax: +55 11 4191 1471

Mexico

Monterrey

Tel: +52 81 8124 0128
Fax: +52 81 8124 0129

Europe, Middle East, Africa

Algeria

Hydra

Tel: +21 3 21 48 1173
Fax: +21 3 21 48 1454

Czech Republic

Netvorice

Tel: +420 317 78 9313
Fax: +420 317 78 9314

France

Baudemont

Tel: +33 385 28 2589
Fax: +33 385 28 0430

Cergy

Tel: +33 130 31 3150
Fax: +33 130 38 6085

Decines

Tel: +33 472 81 5000
Fax: +33 472 81 5010

Germany

Langenfeld

Tel: +49 21 73 8909-0
Fax: +49 21 73 8909 30

Hungary

Budapest

Tel: +36 13 39 8622
Fax: +36 13 39 8622

Italy

Parabiago

Tel: +390 331 49 3311
Fax: +390 331 49 3330

Europe, Middle East, Africa

Ecully, France

Tel: +33 472 18 2020
Fax: +33 472 18 2000

Netherlands

Breda

Tel: +31 76 578 3999
Fax: +31 76 578 3978

Poland

Warsaw

Tel: +48 22 843 3824
Fax: +48 22 843 3471

Portugal

Alfena

Tel: +351 229 69 8840
Fax: +351 229 69 8848

Lisbon

Tel: +351 212 109 340
Fax: +351 212 109 349

Russia

Moscow

Tel: +7 495 641 2359
Fax: +7 495 641 2358

U.A.E.

Dubai

Tel: +971 4 3381 861
Fax: +971 4 3382 343

U. K.

Middlesex

Tel: +44 1 895 43 0053
Fax: +44 1 895 45 9500

Sunderland

Tel: +44 191 522 2000
Fax: +44 191 522 2052

Asia – Pacific

Australia

Melbourne

Tel: +61 3 9 336 1300
Fax: +61 3 9 336 1322

Sydney

Tel: +61 2 9 896 4433
Fax: +61 2 9 896 3122

Asia – Pacific

Shanghai, China

Tel: +86 21 51113579
Fax: +86 21 51113578

Singapore

Tel: +65 6264 1188
Fax: +65 6862 4142

China

Beijing

Tel: +86 10 58674761
Fax: +86 10 58674760

Xi'an

Tel: +86 29 87891465
Fax: +86 29 87884504

Korea

Seoul

Tel: +82 2 3439 0400
Fax: +82 2 3439 0405

Philippines

Makati City

Tel: +63 2 844 9437
Fax: +63 2 844 4712

Factories

U.S.A.

Manitowoc
Port Washington
Shady Grove

Brazil

Alphaville

France

Charlieu
La Clayette
Moulins

India

Calcutta
Pune

Italy

Niella Tanaro

Germany

Wilhelmshaven

Portugal

Fânzeres

China

Zhangjiagang

Constant improvement and engineering progress make it necessary that we reserve the right to make specification, equipment and price changes without notice. Illustrations shown may include optional equipment and accessories, and may not include all standard equipment.

