

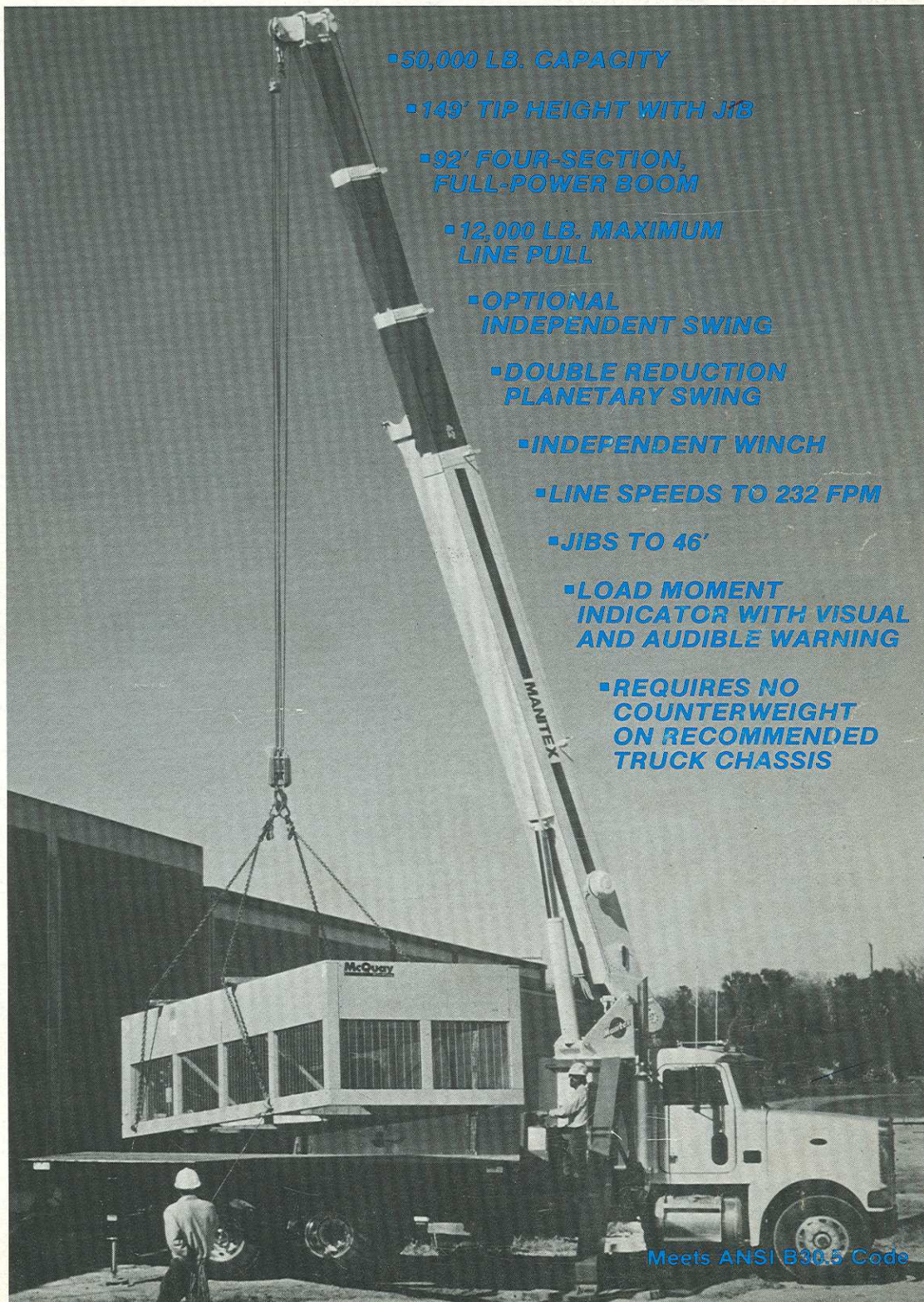

MODEL 2592

HYDRAULIC CRANE



▪ 50,000 LB. CAPACITY

▪ 149' TIP HEIGHT WITH JIB

▪ 92' FOUR-SECTION,
FULL-POWER BOOM

▪ 12,000 LB. MAXIMUM
LINE PULL

▪ OPTIONAL
INDEPENDENT SWING

▪ DOUBLE REDUCTION
PLANETARY SWING

▪ INDEPENDENT WINCH

▪ LINE SPEEDS TO 232 FPM

▪ JIBS TO 46'

▪ LOAD MOMENT
INDICATOR WITH VISUAL
AND AUDIBLE WARNING

▪ REQUIRES NO
COUNTERWEIGHT
ON RECOMMENDED
TRUCK CHASSIS

Meets ANSI B30.5 Code



WEIGHTS

The Manitex 2592 includes a 4-section, 92' boom with anti-two-block warning and shutdown system; two-speed hydraulic winch with 300' of 9/16" wire rope and overhaul ball; rotation bearing and swing system; hydraulic fluid; turret; boom luffing cylinder; pedestal with outriggers; control console with operator platforms; sub-frame; rear stabilizers, boom rest and load moment indicator.

TOTAL CRANE WEIGHT 20,300#

Options:

- 26' fixed-length jib 819#
- 46' telescopic jib 1,230#
- 15-ton single-sheave block 263#
- 25-ton triple-sheave block 380#
- Auxillary sheave for 5 & 6-part line . . 38#
- 20'4" steel bed 1,800#

RECOMMENDED MINIMUM TRUCK CHASSIS

- Wheelbase 234"
- Cab to axle 168"
- Front gross axle weight rating . . . 14,000#
- Rear gross axle weight rating 38,000#
- Truck frame section modulus 20.0 in³
(110,000 PSI)

DO NOT OPERATE A MANITEX HYDRAULIC CRANE OR ACCESSORIES WITHIN 10' OF LIVE POWER LINES.

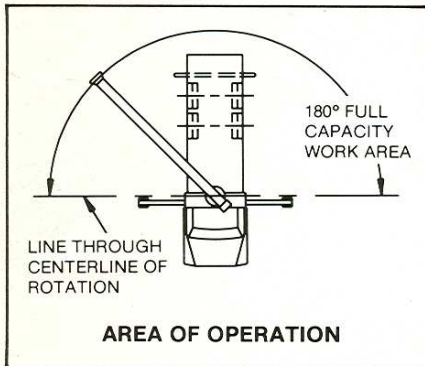

RANGE DIAGRAM

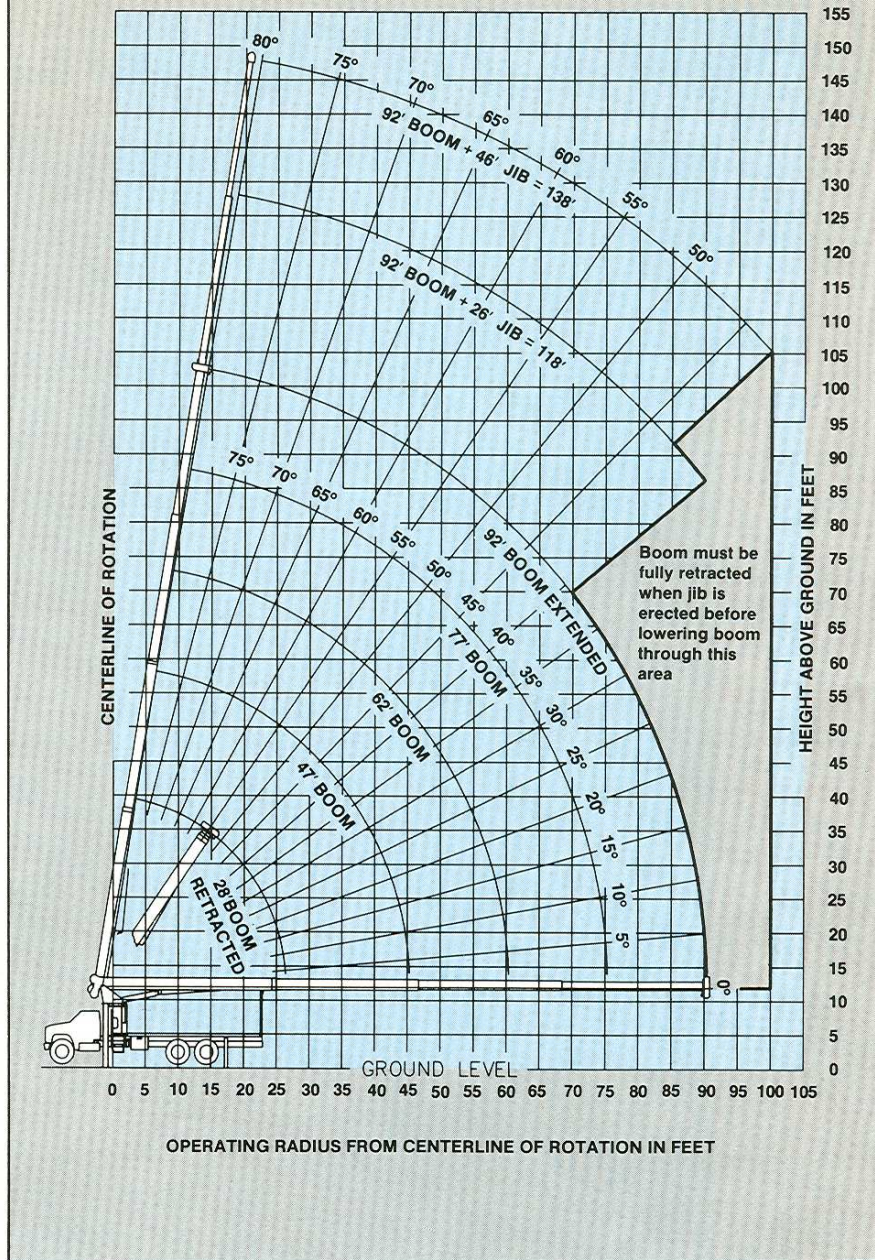

ALLOWABLE LINE PULL						<p>WARNING</p> <p>Anti-two-block system must be in good operating condition before operating crane. Refer to Owner's Manual.</p> <p>Keep at least 3 wraps of load line on drum at all times.</p>
1-PART LINE	2-PART LINE	3-PART LINE	4-PART LINE	5-PART LINE	6-PART LINE	
						<p>WIRE ROPE</p> <p>9/16"-6x25 IWRC (3.5:1 S.F.) 29,750 Lbs. Min. Breaking Strength</p> <p>9/16"-Rotation Resistant (5.0:1 S.F.) 37,000 Lbs. Min. Breaking Strength</p>
8,500 LBS	17,000 LBS	25,500 LBS	34,000 LBS	42,500 LBS	50,000 LBS	
7,400 LBS	14,800 LBS	22,200 LBS	29,600 LBS	37,000 LBS	44,400 LBS	



MANITEX 2592 CAPACITY CHART

LOAD RATINGS IN POUNDS WITH OUTRIGGERS AND STABILIZERS EXTENDED											JIB LOAD RATINGS IN POUNDS WITH OUTRIGGERS AND STABILIZERS EXTENDED										
Operating Radius	Boom Angle	28' Boom		47' Boom		62' Boom		77' Boom		92' Boom		Operating Radius	FIXED JIB		TELESCOPIC JIB						
		Boom Angle	Capacity	Boom Angle	Capacity	Boom Angle	Capacity	Boom Angle	Capacity	Boom Angle	Capacity		Boom Angle	26' Jib-All Boom Lengths	Capacity	Boom Angle	26' Jib-All Boom Lengths	Capacity	46' Jib-All Boom Lengths	Capacity	
5'	79°		50000									10'									
8'	72°		37800									12'									
10'	68°		32000	78°	20500							15'									
12'	63°		26650	75°	20500	79°	20500					20'									
15'	56°		20900	71°	20500	77°	18300	80°	15000			25'									
20'	42°		15000	65°	15000	72°	14800	76°	12700	79°	9900	25'	79°	5500	79°	5300					
25'	21°		11300	58°	11300	67°	11300	72°	10900	76°	8680	30'	77°	5000	77°	4850	79°	3400			
30'				50°	9170	62°	9170	68°	9170	73°	7740	35'	75°	4610	75°	4350	77°	3300			
35'				41°	7400	56°	7400	64°	7400	70°	6760	40'	72°	4160	72°	3900	76°	3200			
40'				30°	6050	50°	6050	60°	6050	66°	5920	45'	70°	3750	70°	3480	74°	3040			
45'						43°	5000	55°	5000	63°	5000	50'	67°	3380	67°	3110	72°	2780			
50'						36°	4190	50°	4190	59°	4190	55'	65°	3070	65°	2800	69°	2520			
55'						26°	3400	45°	3400	55°	3400	60'	62°	2790	62°	2500	67°	2280			
60'								39°	2830	51°	2830	65'	59°	2480	59°	2190	65°	2070			
65'								32°	2310	46°	2310	70'	56°	2040	56°	1750	62°	1880			
70'								24°	1880	42°	1880	75'	53°	1670	53°	1380	60°	1710			
75'										36°	1550	80'	49°	1350	49°	1060	58°	1520			
80'										30°	1240	85'	46°	1080	46°	780	55°	1240			
85'										22°	970	90'	42°	840	42°	540	52°	990			
90'												95'					49°	780			
95'												100'					46°	580			
100'																					
			460 LBS		270 LBS		210 LBS		170 LBS		140 LBS	< Deductions for stowed FIXED JIB									
			690 LBS		410 LBS		310 LBS		250 LBS		210 LBS	< Deductions for stowed TELESCOPIC JIB									

- Before operating this equipment, the operator should read and understand the Operator's & Owner's Manual and capacity chart.
- All load ratings below the heavy line on the capacity chart are stability limited capacities, and do not exceed 85% of tipping.

- The operating radius shown in the jib rating charts is for fully extended boom only. When boom is not fully extended, use only loaded boom angle to determine load rating of jib.
- Deductions must be made from the rated load for stowed jib, optional attachments, hooks, load blocks, and other rigging equipment.

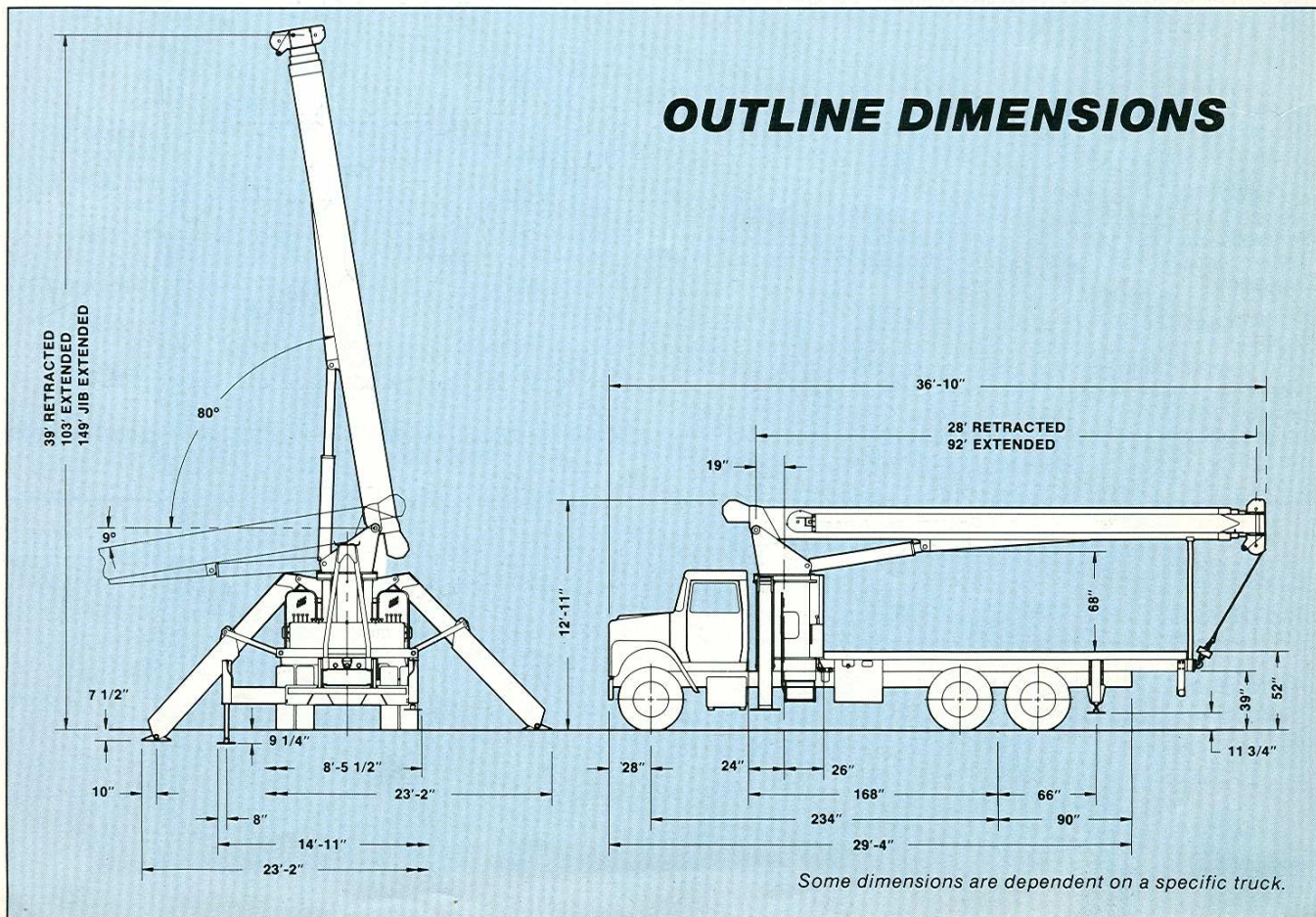



MODEL 2592 GENERAL SPECIFICATIONS

BOOM — Standard four-section, telescoping, box boom extends from 28' to 92' in just 72 seconds. Consists of a base pinned to the turret and three powered sections that extend and retract on durable, low-maintenance nylon pads. All boom sections are fabricated from high-strength, low-alloy steel. Powered sections extend and retract simultaneously by a hydraulic cylinder and a compound cable-crowd system.

SWING-AROUND JIBS — Fabricated from high-strength, low-alloy steel, Manitex swing-around jibs store conveniently along the boom's base section. Available as 26' fixed length or 46' telescopic options, Manitex jibs easily pin-connect to the boom point and are equipped with low-maintenance, non-metallic sheaves.

WINCH — Powered by a gear-type hydraulic motor driving a double-planetary reducer. A counterbalance valve and a spring-applied, hydraulically-released, wet-disc brake prevent unexpected payout of hoist rope. Maximum line pull is 12,000 pounds (first layer). Maximum line speed is 232 FPM.

TURRET — A precision-bored weldment, the turret supports the boom and the boom-luffing cylinder.

SWING SYSTEM — Generating swing speeds to 1.5 RPM, the system is powered by a hydraulic motor that drives through a two-stage planetary reducer to a pinion meshing with the ring gear on the rotation bearing. For operator safety, the pinion and ring gear are both fully enclosed. The system also includes a wet-disc brake, which is spring-set automatically when the swing control lever is in neutral position. Maximum non-continuous swing arc is 372°.

BOOM HOIST — A double-acting hydraulic cylinder accurately positions the boom at any angle from 9° below horizontal to 80° above, covering the entire range in approximately 42 seconds. A counterbalance valve prevents the boom from lowering unexpectedly.

ROTATION BEARING — An antifriction bearing designed for long life and easy maintenance enables smooth, efficient swinging of the turret and boom. The inner race is bolted to the pedestal; the outer race to the turret.

PEDESTAL — Bolted to the sub-frame and to tie plates beneath the truck chassis, the pedestal is a rugged steel weldment which solidly supports the swing system, turret, front outriggers, and operator's stations.

SUB-FRAME — Mounted on top the truck chassis, the sub-frame resists reactions imposed by lifted loads, thereby minimizing stress on the truck. Clamped securely to the chassis by threaded rods and tie plates, the sub-frame is mounted without drilling, welding, or other modification of the truck chassis.

CONTROL SYSTEM — Twin platforms, with foot throttle, are mounted on opposite sides of the pedestal. Manually-actuated hydraulic controls with four-way, open-center valves assure smooth, precise operation. Controls arranged in the ANSI B30.5 sequence.

HYDRAULIC SYSTEM — A power take off on truck's transmission drives a pump that powers all functions. The open-loop system includes a 80-gallon reservoir with magnetic drain plug, a 10-micron filter in the return line, and a system pressure gauge. All high-pressure fittings are SAE face seal O-ring, O-ring boss, or bolted-flange connection. With the standard pump operating at 2,000 RPM

and 100 PSI, maximum flow to the winch is 35 GPM; maximum winch pressure is 2,800 PSI; maximum flow to all other functions is 18 GPM; maximum swing pressure 1,500 PSI; and maximum pressure in all other circuits 2,800 PSI.

FRONT OUTRIGGERS — Extend and retract in an arching motion that minimizes skidding during setup. Controlled by hydraulic cylinders with counterbalance valves, the outriggers retract to an 8'0" width for easy roadability, extend to 21'6" for lifting stability, and provide a maximum raise of 7 1/2".

REAR STABILIZERS — Out-and-down rear stabilizers extend to 13'11" for lifting stability and retract to 8'0" for road travel. The two horizontal beams extend and retract by a double-acting hydraulic cylinder. Hydraulic leveling jacks, mounted vertically to the end of each beam, are equipped with 12" diameter pads. Beams and jacks are controlled independently.

BED — Optional 8' x 20' Manitex bed bolts to the sub-frame without welding or match drilling. Constructed of steel plate with cross sills every 12".

BOOM REST — An easily-removable steel fabrication set into slots at the rear of the sub-frame supports the boom during travel.

BOOM POINT — Three low-maintenance, non-metallic sheaves mounted on heavy-duty antifriction bearings guide the load line over the boom point and allow up to four-part line operation. An optional single-sheave hanger permits reeving six-part line for maximum capacity.

HOOK BLOCKS — A 5-ton capacity swivel hook with weight ball is standard. Options include a single-sheave block for up to three parts of line; a triple-sheave block for up to four parts of line; and a single-sheave hanger used with the triple-sheave block for five- and six-part line.

SAFETY FEATURES — Anti-two-block audible warning and shutdown, engine stop switches, warning horn, backup alarm and load moment indicator with visual and audible warning are standard.

WARRANTY — Manitex hydraulic cranes are backed with a comprehensive 12-month warranty. A network of distributors provides parts and service support.

OPTIONS

- 9/16" rotation resistant wire rope
- Hook blocks for two to six parts of line
- Single-sheave hanger for five and six part line
- 26' fixed-length jib
- 46' telescopic jib
- Remote controls
- Man baskets
- Pallet forks
- Roofer's tools
- Clamshell buckets
- Hydraulic hose reel
- Front bumper outriggers for lifting over front of truck
- Hydraulic swivel for 360° continuous rotation
- Oil cooler for duty-cycle applications
- LMI overload shutdown system
- Dunnage boxes
- 8' x 20' wood or steel bed
- Trash dumpster
- Various mounting configurations

MANITEX, INC.

A Subsidiary of The Manitowoc Company, Inc.

4300 Acapulco Avenue ■ McAllen, Texas 78503
Telephone: 512-630-2690 ■ Telefax: 512-630-2695

Because of a program of continuing improvements, Manitex, Inc. reserves the right to change this description and product specifications, at any time, without notice.

