



Technical Data

Specifications & Capacities

TCC500

Telescopic Crawler Crane
50 Ton (51mt Export Machine)

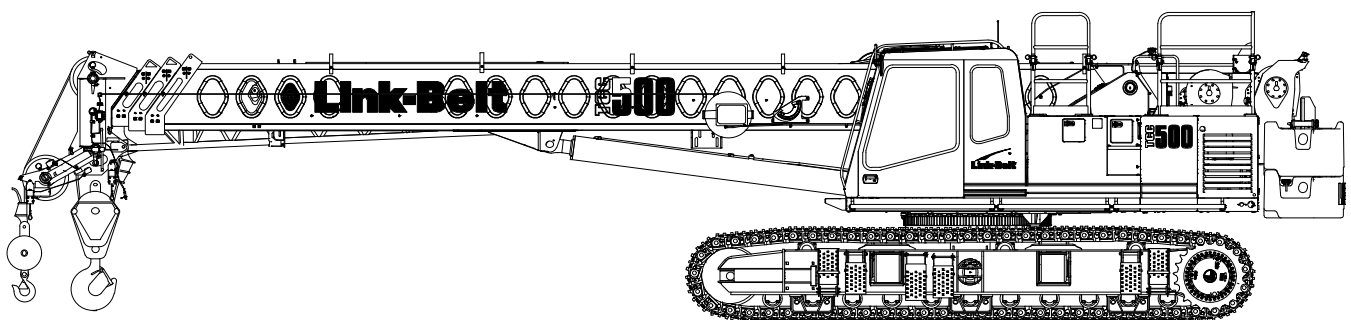

CAUTION: This material is supplied for reference use only. Operator must refer to in-cab Crane Rating Manual and Operator's Manual to determine allowable crane lifting capacities and assembly and operating procedures.



5646-0314-S5



Table Of Contents

| | |
|---|-----------|
| Upper Structure | 1 |
| Frame | 1 |
| Engine | 1 |
| Hydraulic System | 1 |
| Load Hoist Drums | 1 |
| Swing System | 1 |
| Counterweight | 1 |
| Operator's Cab | 1 |
| Rated Capacity Limiter System | 2 |
| Machinery House | 2 |
| Catwalks | 2 |
| Optional Vandal Guards | 2 |
| Lower Structure | 2 |
| Carbody | 2 |
| Side Frames | 2 |
| Travel and Steering | 2 |
| Tool Boxes | 2 |
| Boom | 3 |
| Design | 3 |
| Boom | 3 |
| Boom Head | 3 |
| Boom Elevation | 3 |
| Optional Equipment | 3 |
| Auxiliary Lifting Sheave | 3 |
| Hook Blocks And Balls | 3 |
| Fly & Attachments | 3 |
| Work Platform | 3 |
| Auger Mounting (Under Design) | 3 |
| Dimensions | 4 |
| Base Crane | 4 |
| Auxiliary Lifting Sheave | 6 |
| Fly | 6 |
| Counterweights | 7 |
| Hook Balls | 8 |
| Hook Blocks | 8 |
| Augers | 9 |
| Working Weights | 10 |
| Transport Drawing | 10 |
| Load Hoist Performance | 10 |
| Working Areas | 11 |
| Boom Extend Modes | 12 |
| Attachments | 13 |
| Main Boom Working Range Diagrams | 14 |
| Main Boom + Fly Working Range Diagrams | 16 |
| Main Boom Load Charts | 17 |
| Main Boom + Fly Load Charts | 19 |



5646-0314-S5

This Page Intentionally Blank



Upper Structure

Frame

All welded steel frame with precision machined surfaces for mating parts.

Turntable Bearing

- Inner race is bolted to upper frame
- Outer race with external swing gear is bolted to lower frame

Engine

Engine

Full pressure lubrication, oil filter, air cleaner, hour meter, throttle, and electric control shutdown.

| Specification | Cummins QSB | |
|---|----------------------------|----------------------------|
| | Tier 4f (Stage 3B) | Tier 3 (Stage 3A) |
| Numbers of Cylinders | 6 | 6 |
| Cycle | 4 | 4 |
| Bore & Stroke: inch (mm) | 4.21 x 4.88 (107 x 124) | 4.21 x 4.88 (107 x 124) |
| Piston Dis- placement: in ³ (L) | 409 (6.7) | 409 (6.7) |
| Max. Brake Horsepower: hp (kW) | 215 (160) @ 1,800 rpm | 205 (153) @ 1,800 rpm |
| Peak Torque: ft lb (Nm) | 700 (949) @ 1,500 rpm | 689 (929) @ 1,300 rpm |
| Alternator: volt – amps | 12 – 150 | 12 – 160 |
| Crankcase Capacity: qt (L) | 19 (18) | 19 (18) |
| <ul style="list-style-type: none"> • Engine driven variable speed viscus fan clutch and thermostatically controlled radiator | | |

Fuel Tank

One 80 gal (303L) capacity fuel tank.

Hydraulic System

Hydraulic Pumps

The pump arrangement is designed to provide hydraulically powered functions allowing positive, precise control with independent or simultaneous operation of all crane functions.

- One variable displacement pumps provide independent control for hoist drums, boom hoist, boom extend, and right & left travel.
- Two gear type pumps are used for the swing, retract cylinders & operator's controls and hydraulic oil cooling fan.

Hydraulic Reservoir

133 gal (504L) capacity equipped with sight level gauge. Diffusers built in for deaeration.

Filtration

One 10 micron, full flow return line filter. Accessible for easy filter replacement.

Counterbalance Valves

All hoist motors are equipped with counterbalance valves to provide positive load lowering and prevent accidental load drop if the hydraulic pressure is suddenly lost.

Load Hoist Drums

Main and Optional Auxiliary Winches

- Axial piston, full and half displacement (2-speed) motor driven through planetary reduction unit for positive control under all load conditions.
- Grooved lagging
- Power up/down mode of operation
- Hoist drum cable follower – optional
- Drum rotation indicator
- Drum diameter: 10.63 in (27cm)
- Rope length:
 - Main: 600 ft (182.9m)
 - Auxiliary: 450 ft (137.2m) or 600 ft (182.9m)
- Maximum rope storage: 737 ft (224.6m)
- Terminator style socket and wedge

Third wrap indicator – optional – Visually and audibly warns the operator when the wire rope is on the first/bottom layer and when the wire rope is down to the last three wraps

Swing System

Motor/Planetary – Bi-directional hydraulic swing motor mounted to a planetary reducer for 360° continuous smooth swing at 2.0 rpm

Swing Park Brake – 360°, electric over hydraulic, (spring applied/hydraulic released) multi-disc brake mounted on the speed reducer. Operated by a switch in the operator's cab.

Swing Brake – 360°, foot operated, hydraulic applied disc brake mounted to the speed reducer

House Lock – Two-position house lock (boom over front or rear) operated from the operator's cab

Counterweight

Consists of a five piece design.

- One "A" counterweight, 12,000 lb (5 443kg)
- One "B" counterweight, 13,000 lb (5 897kg)
- Optional one "C" counterweight, 5,000 lb (2 268kg)
- Optional two "A" carbody counterweights, 3,000 lb (1 361kg) each with tool box built in

Operator's Cab

Fully enclosed modular steel compartment is independently mounted and padded to protect against vibration and noise.

- All tinted/tempered safety glass
- Sliding entry door and front and rear window
- Swing up roof window with windshield wiper
- Door and window locks
- Hot water heater
- Air conditioner
- Sun visor
- Cloth seat
- Circulating fan
- Windshield wipers and washer
- Dry chemical fire extinguisher
- Engine instrumentation panel (tachometer, voltmeter, engine oil pressure, engine water temperature, fuel level, hydraulic oil temperature, hour meter, and service monitor system)
- Mechanical drum rotation indicators for main (rear) and auxiliary (front) hoist drums
- Six way adjustable seat
- Foot throttle
- Joystick controls
- Optional fully adjustable single axis controls
- Bubble type level
- Ergonomic gauge layout
- Controls shut off lever
- AM/FM Radio
- Travel levers & pedals
- Camera (winch & rear view)



Rated Capacity Limiter System

Pulse graphic audio—visual warning system with anti—two block and function limiter. Operating data available includes:

- Crane configuration
- Boom length
- Boom head height
- Allowed load and % of allowed load
- Data logging

- Boom angle
- Radius of load
- Actual load
- Operator settable alarms (include):
 - Maximum and minimum boom angles
 - Maximum tip height
 - Maximum boom length
 - Swing left/right positions
 - Operator defined area (imaginary plane)

Machinery House

Hinged doors (four on right side) for machinery access.

Catwalks

Standard on right and left sides. Catwalks fold up and pin for reduced travel width.

Optional Vandal Guards

Under design

Lower Structure

Carbody

Lower Frame

All welded box construction frame with precision machined surfaces for turntable bearing and rotating joint.

Side Frames

Side Frames

All welded, precision machined, steel frames can be hydraulically extended and retracted with a hydraulic cylinder mounted in the lower frame.

- 12 ft 6.88 in (3.83m) extended gauge
- 10 ft 10.62 in (3.31m) intermediate gauge
- 8 ft 9.74 in (2.68m) retracted gauge
- 19 ft 6.19 in (5.95m) overall length
- 31 in 6 in (0.80m) wide track shoes
- Sealed (oil filled) idler and drive planetaries
- Compact travel drives
- Hydraulic self adjusting tracks

Track Rollers

- Eleven sealed (oil filled) track rollers per side frame
- Heat treated, mounted on anti—friction bearings

Tracks

Heat treated, self—cleaning grouser shoes and heat treated track pins with dirt seals. 61 track shoes per side.

- Optional flat or “street” pad

Take Up Idlers

Cast steel, heat treated, self—cleaning, mounted on sealed tapered roller bearings

Travel and Steering

Each side frame contains a pilot controlled, bi—directional, axial piston motor and a planetary gear reduction unit to provide positive control under all load conditions.

- 2—speed travel
- Individual control provides smooth, precise maneuverability including full counter—rotation.
- Spring applied, hydraulically released multiple wet—disc type brake controlled automatically
- Maximum travel speed is 2 mph (3.2km/h).
- Designed to 40% gradeability

Tool Boxes

Two heavy duty steel design tool boxes that bolt onto the carbody.



Boom

Design

Four section, box type construction of high tensile steel consisting of one base section and three telescoping sections. The vertical side plates have diamond shaped steel impressions for superior strength to weight ratio. The first telescoping section extends independently by means of one double-acting, single stage hydraulic cylinder with integrated holding valves. The second and third telescoping sections extend proportionally by means of one double-acting, single stage cylinder with integrated holding valves and cables.

Boom

- 35 ft 6 in–110 ft (10.8–33.8m) four section full power boom
- Two mode boom extension: A*max mode provides superior capacities by extending the first telescoping section to 60 ft 4 in (18.4m). Standard mode synchronizes all the telescoping sections proportionally to 110 ft (33.5m). Controlled from the operator's cab.
- Mechanical boom angle indicator
- Maximum tip height for A–max mode is 67 ft (20.4m) and standard mode is 115 ft 6 in (35.2m).

Boom Head

- Four 16.5 in (41.9cm) root diameter sealed bearings nylon sheaves to handle up to eight parts of line
- Easily removable wire rope guards
- Rope dead end lugs on each side of the boom head
- Boom head is designed for quick-reeve of the hook block

Boom Elevation

- One double acting hydraulic cylinder with integral holding valve
- Boom elevation: –3° to 78°

Optional Equipment

Auxiliary Lifting Sheave

- Single 16.5 in (41.9m) root diameter nylon sheave
- Easily removable wire rope guard
- Does not affect erection of the fly or use of the main head sheaves

Hook Blocks And Balls

- 25 ton (22.3mt) 3 sheave quick-reeve hook block with safety latch
- 40 ton (36.3mt) 4 sheave quick-reeve hook block with safety latch
- 50 ton (44.6mt) 5 sheave quick-reeve hook block with safety latch
- 8.5 ton (7.7mt) swivel and non-swivel hook balls with safety latch

Fly & Attachments

- 28.5 ft (11.7m) one piece lattice fly, stowable, offsettable to 2°, 20°, and 40°. Maximum tip height is 143.5 ft (43.74m).
- 28.5–51 ft (8.7–15.6m) two piece bi-fold lattice fly, stowable, offsettable to 2°, 20°, and 40°. Maximum tip height is 165.5 ft (50.44m).

Work Platform

- Boom mounted work platform under design.

Auger Mounting (Under Design)

This option provides for all parts required for installation of "Pengo Model DT15 & RT-20 Augers". Included in option are all operator cabin controls, main hydraulic valve, and plumbing. The auger mounts to the boom tip section in operational mode and stores on the base section when not working. Design allows for limited boom extend and retract while drilling, allowing for straight vertical drilling.



Dimensions

Base Crane

| General Dimensions | English | Metric |
|---------------------|-------------|------------|
| Basic Boom | 35.5–110 ft | 10.8–33.5m |
| Minimum Load Radius | 10 ft | 3.05m |
| Maximum Boom Angle | 78° | 78° |
| Track Shoe Width | 31.5 in | 0.80m |

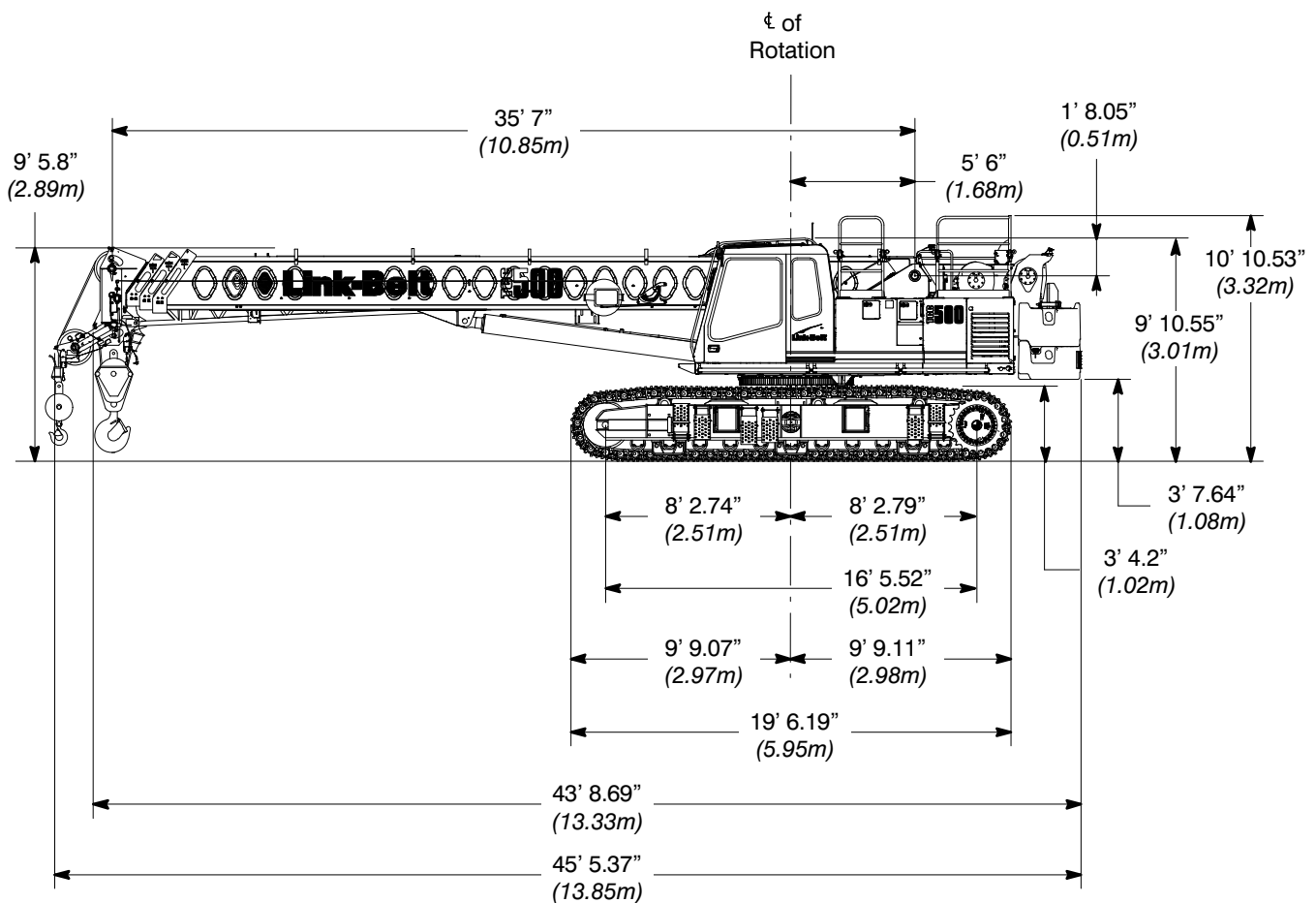

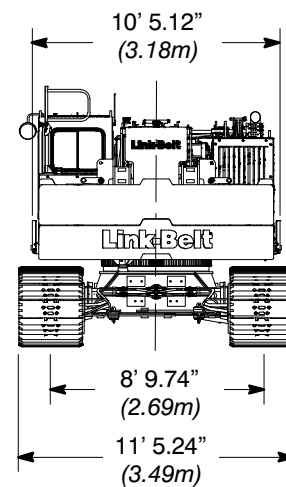
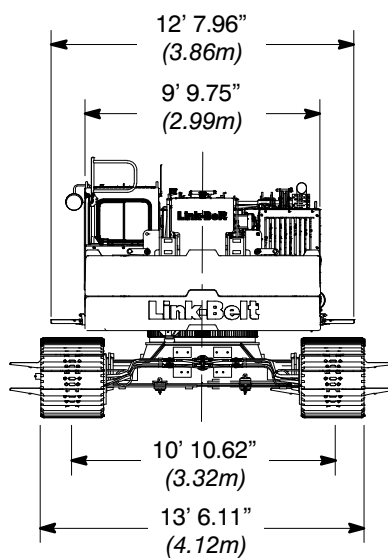
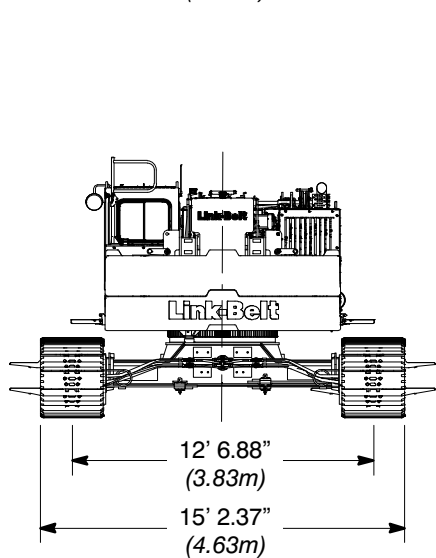
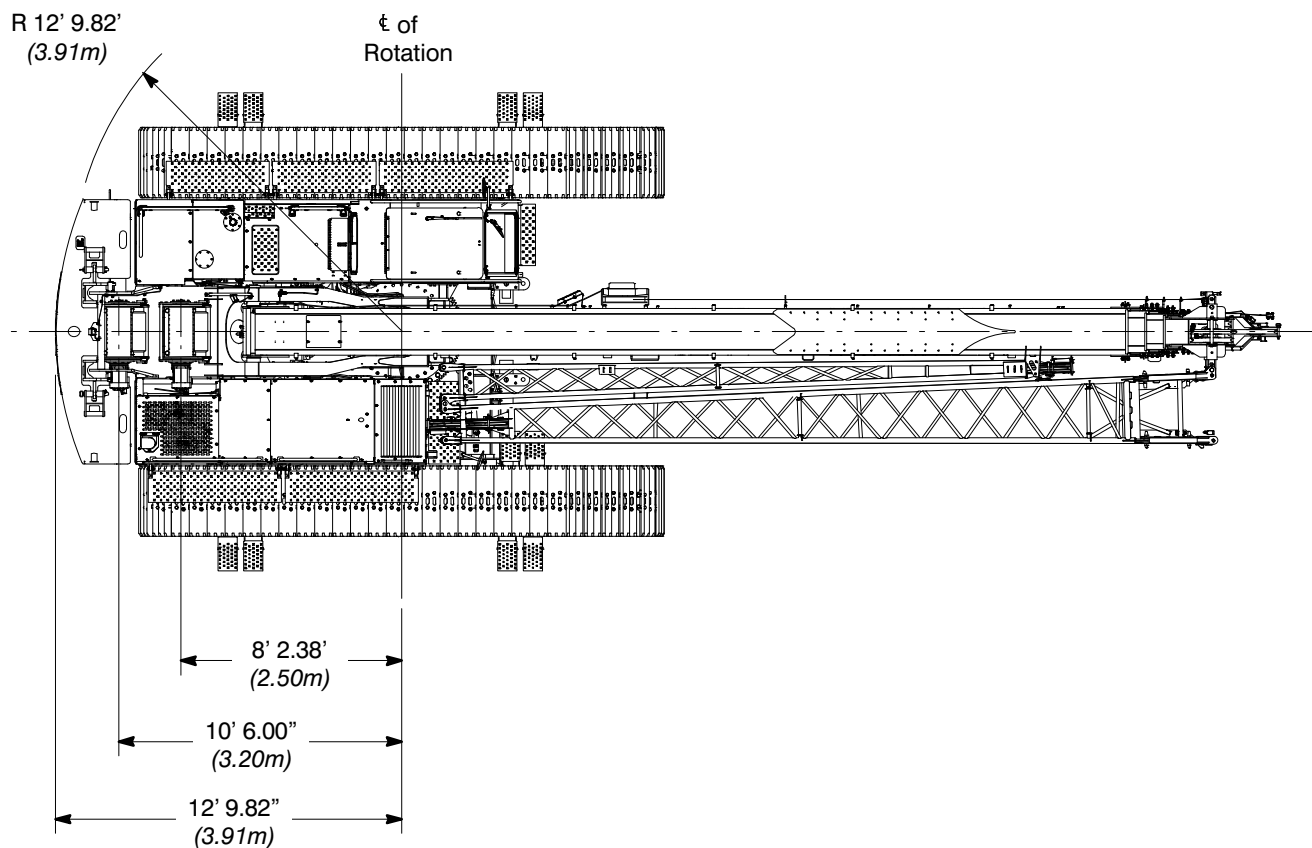



Auxiliary Lifting Sheave

Auxiliary Lifting Sheave ①

| | | |
|--------|----------|---------|
| Length | 35.31 in | (0.90m) |
| Width | 16.31 in | (0.41m) |
| Height | 19 in | (0.48m) |
| Weight | 92.5 lb | (42kg) |

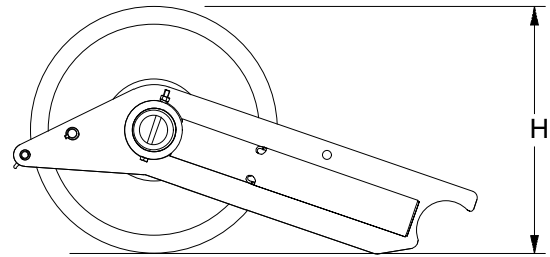
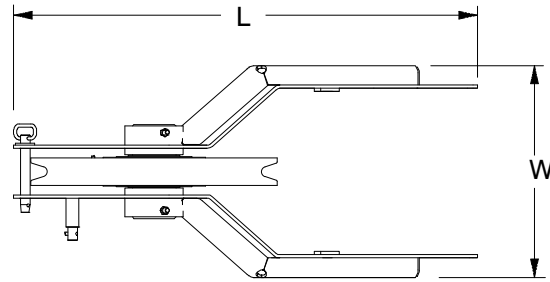

Fly

28.5 ft (8.69m) Offset Fly One Piece Lattice Fly (Base Fly) ①

| | | |
|--------|----------|---------|
| Length | 28.5 ft | (8.69m) |
| Width | 29 in | (0.74m) |
| Height | 30 in | (0.76m) |
| Weight | 1,188 lb | (539kg) |

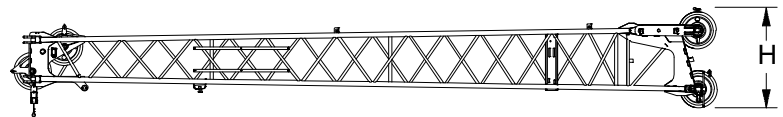
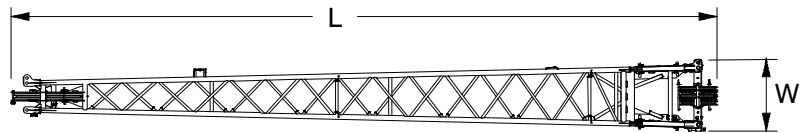

22.5 ft (6.86m) Lattice Fly Tip (Addition To Base Fly For 28.5-51 ft (8.69-15.55m) Bi-fold Fly) ①

| | | |
|--------|----------|---------|
| Length | 22.5 ft | (6.86m) |
| Width | 13.78 in | (0.35m) |
| Height | 20 in | (0.51m) |
| Weight | 654 lb | (297kg) |

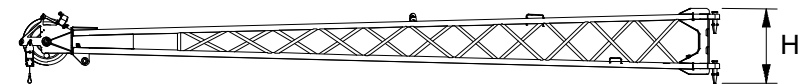
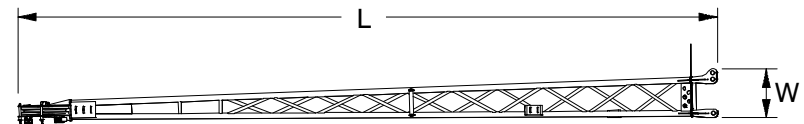

Number inside black circle "①" = # of components

* - Optional equipment



5646-0314-S5

Counterweights

"A" Counterweight ①

| | | |
|--------|--------------|-----------|
| Length | 32.90 in | (0.84m) |
| Width | 9 ft 10 in | (3.00m) |
| Height | 4 ft 2.18 in | (1.28m) |
| Weight | 12,000 lb | (5 443kg) |

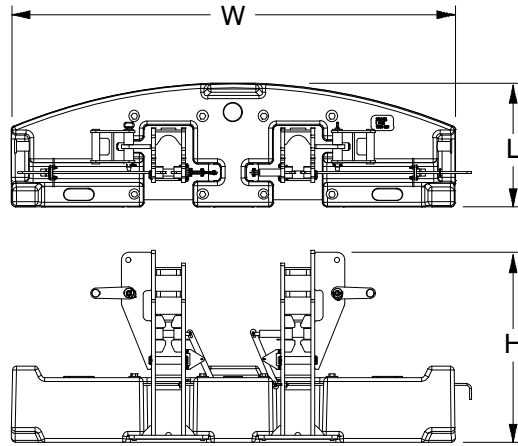

"B" Counterweights ①

| | | |
|--------|------------|-----------|
| Length | 32.90 in | (0.84m) |
| Width | 9 ft 10 in | (3.00m) |
| Height | 23 in | (0.58m) |
| Weight | 13,000 lb | (5 897kg) |

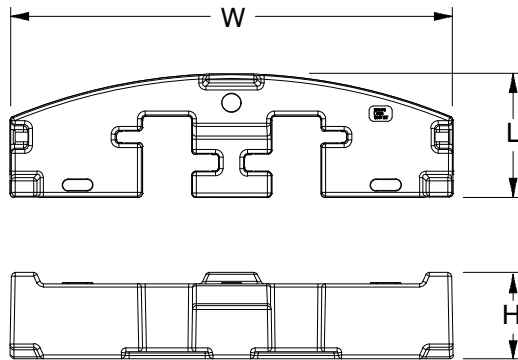

Optional "C" Counterweights ①

| | | |
|--------|------------|-----------|
| Length | 32.90 in | (0.84m) |
| Width | 9 ft 10 in | (3.00m) |
| Height | 8.50 in | (0.22m) |
| Weight | 5,000 lb | (2 268kg) |

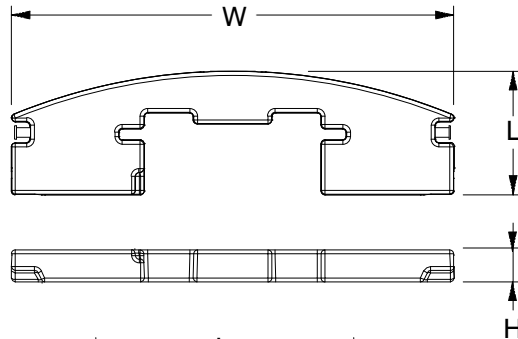

Optional "A" Carbody Counterweights ②

| | | |
|--------|----------|-----------|
| Length | 62.50 in | (1.59m) |
| Width | 30 in | (0.76m) |
| Height | 20.12 in | (0.51m) |
| Weight | 3,000 lb | (1 361kg) |

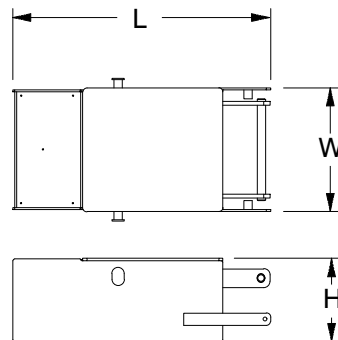

Number inside black circle "①" = # of components

* - Optional equipment



Hook Balls

8.5 Ton (7.7mt) Swivel Hook Ball* ①

| | | |
|--------|----------|---------|
| Width | 14.50 in | (0.37m) |
| Height | 33.75 in | (0.86m) |
| Weight | 325 lb | (163kg) |

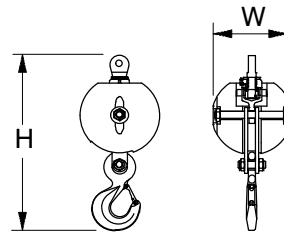

8.5 Ton (7.7mt) Non-Swivel Hook Ball* ①

| | | |
|--------|----------|---------|
| Width | 14.50 in | (0.37m) |
| Height | 33.80 in | (0.86m) |
| Weight | 360 lb | (163kg) |

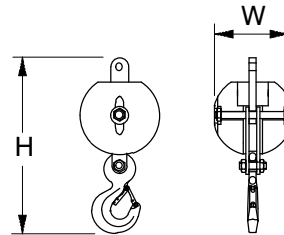

Hook Blocks

25 Ton (22.3mt)

3-Sheave Hook Block* ①

| | | |
|--------|----------|---------|
| Width1 | 15.14 in | (0.39m) |
| Width2 | 17.88 in | (0.45m) |
| Height | 41.17 in | (1.05m) |
| Weight | 670 lb | (304kg) |

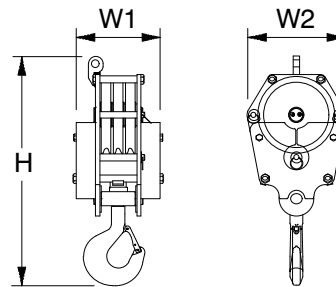

40 Ton (36.3mt)

4-Sheave Hook Block* ①

| | | |
|--------|----------|---------|
| Width1 | 16.44 in | (0.42m) |
| Width2 | 17.88 in | (0.45m) |
| Height | 47.82 in | (1.22m) |
| Weight | 780 lb | (354kg) |

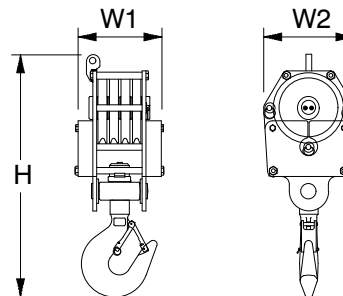

50 Ton (44.6mt)

5-Sheave Hook Block* ①

| | | |
|--------|----------|---------|
| Width1 | 18.75 in | (0.48m) |
| Width2 | 18.25 in | (0.46m) |
| Height | 52.31 in | (1.33m) |
| Weight | 1,090 lb | (494kg) |

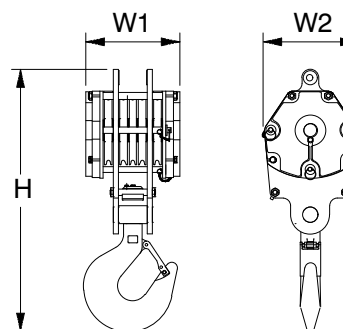

Number inside black circle "①" = # of components

* - Optional equipment



Augers

DT-15 Auger* 1

| | | |
|-----------|----------|----------|
| Width | 16.12 in | (0.41m) |
| Height | 52.12 in | (1.32m) |
| Weight | 710 lb | (322kg) |
| Hex Shaft | 2.5 in | (6.35cm) |

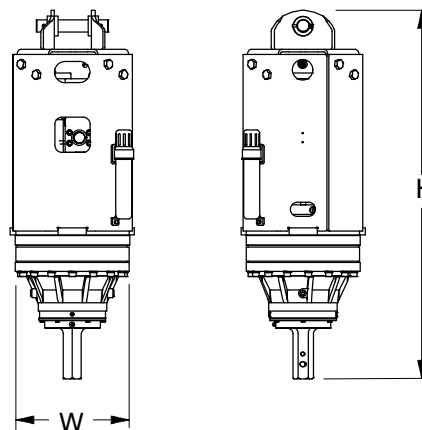

RT-20 Auger* 1

| | | |
|-----------|----------|----------|
| Width | 16.12 in | (0.41m) |
| Height | 52.12 in | (1.32m) |
| Weight | 737 lb | (334kg) |
| Hex Shaft | 3 in | (7.62cm) |

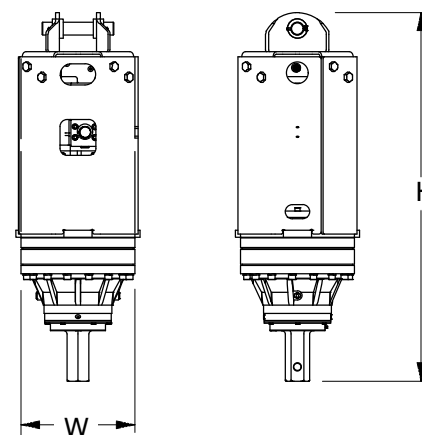

Number inside black circle “1” = # of components
 * – Optional equipment



Working Weights

| Option | Description | Gross Weight lb (kg) | Ground Bearing Pressure (on soft ground) psi (kg/cm ²) |
|--------|---|-------------------------|--|
| 1 | Base crane, "AB" counterweight, lower toolbox, 600 ft (182.9m) type "ZB" main wire rope, 450 ft (137.2m) type "ZB" auxiliary wire rope, 2-piece fly, 40 ton (36.29mt) 4 sheave hook block, 8.5 ton (7.71mt) hook ball, and a 250 lb (113kg) operator. | 100,000 (45 359kg) | 8.88 (0.62) |

Notes: Ground bearing pressure is based on the total weight distributed evenly over the track contact area.

Transport Drawing

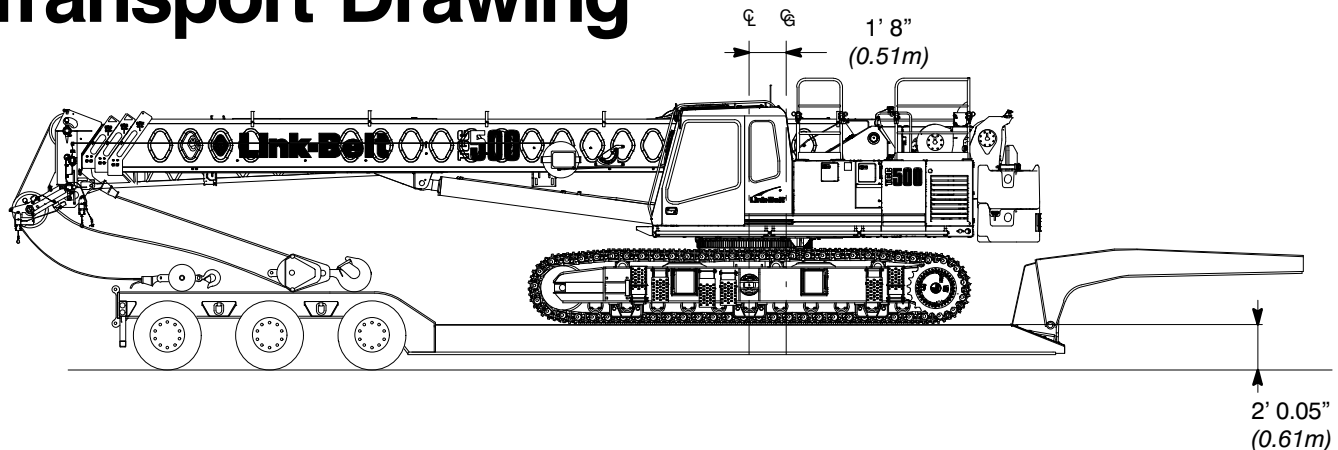

Transport Weight – 99,750 lb (45 246kg)

Base crane, "AB" Counterweight, 600 ft (182.9m) type "ZB" main wire rope, 450 ft (137.2m) type "ZB" auxiliary wire rope, 2-piece fly, 40 ton (36.29mt) 4 sheave hook block, and 8.5 ton

Load Hoist Performance

Main (Rear) and Auxiliary (Front) Winches – 5/8 in (16mm) Rope

| Layer | Maximum Line Pull | | Normal Line Speed | | High Line Speed | | Layer | | Total | |
|-------|-------------------|-------|-------------------|-------|-----------------|-------|-------|------|-------|-------|
| | lb | kN | ft/min | m/min | ft/min | m/min | ft | m | ft | m |
| 1 | 17,084 | 75.99 | 181 | 55.2 | 360 | 109.6 | 97 | 29.6 | 97 | 29.6 |
| 2 | 15,454 | 68.74 | 200 | 61.1 | 398 | 121.2 | 107 | 32.6 | 205 | 62.4 |
| 3 | 14,107 | 62.75 | 219 | 66.9 | 436 | 132.8 | 118 | 35.9 | 322 | 98.3 |
| 4 | 12,977 | 57.72 | 239 | 72.7 | 474 | 144.3 | 128 | 39.0 | 451 | 137.3 |
| 5 | 12,014 | 53.44 | 258 | 78.6 | 511 | 155.9 | 138 | 42.1 | 589 | 179.5 |
| 6 | 11,184 | 49.75 | 277 | 84.4 | 549 | 167.5 | 149 | 45.3 | 737 | 224.7 |

| Wire Rope Application | | Diameter | | Type | Maximum Permissible Load | |
|-------------------------|----------|----------|----|--|--------------------------|---------|
| | | in | mm | | lb | kg |
| Main (Rear) Winch | Standard | 5/8 | 16 | 34x7 rotation resistant – right regular lay or right lang lay (Type ZB) | 11,080 | 5 025.8 |
| | Optional | 5/8 | 16 | 18x19 rotation resistant – right regular lay or right lang lay (Type RB) | 9,080 | 4 118.6 |
| | Optional | 5/8 | 16 | 6x19 IWRC – right regular lay (Type DB) | 11,771 | 5 339.2 |
| Auxiliary (Front) Winch | Standard | 5/8 | 16 | 34x7 rotation resistant – right regular lay (Type ZB) | 11,080 | 5 025.8 |
| | Optional | 5/8 | 16 | 18x19 rotation resistant – right regular lay (Type RB) | 9,080 | 4 118.6 |
| | Optional | 5/8 | 16 | 6x19 IWRC – right regular lay (Type DB) | 11,771 | 5 339.2 |



Working Areas

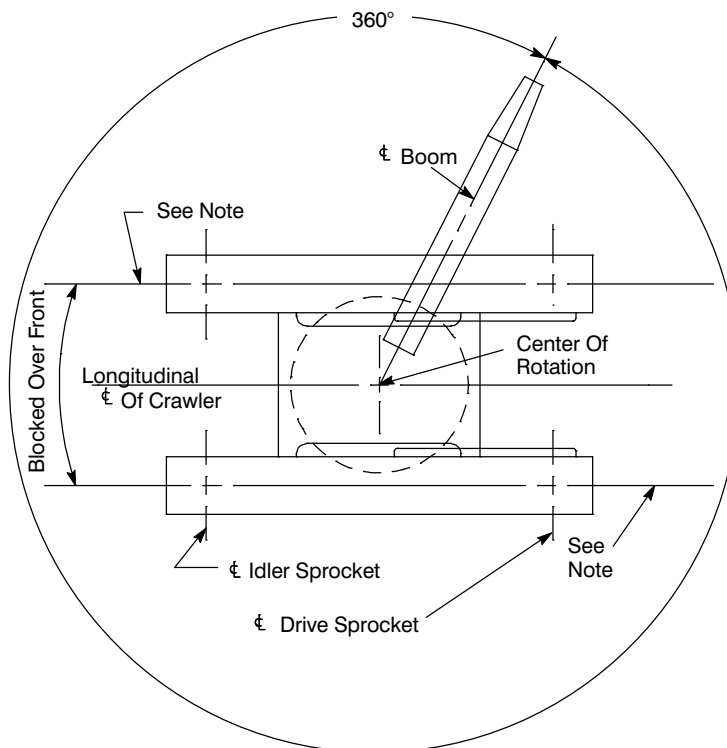

Note: These Lines Determine The Limiting Position Of Any Load For Operation Within Working Areas Indicated.



Boom Extend Modes

Boom Mode "A" (A-max)

Only inner mid section telescopes.

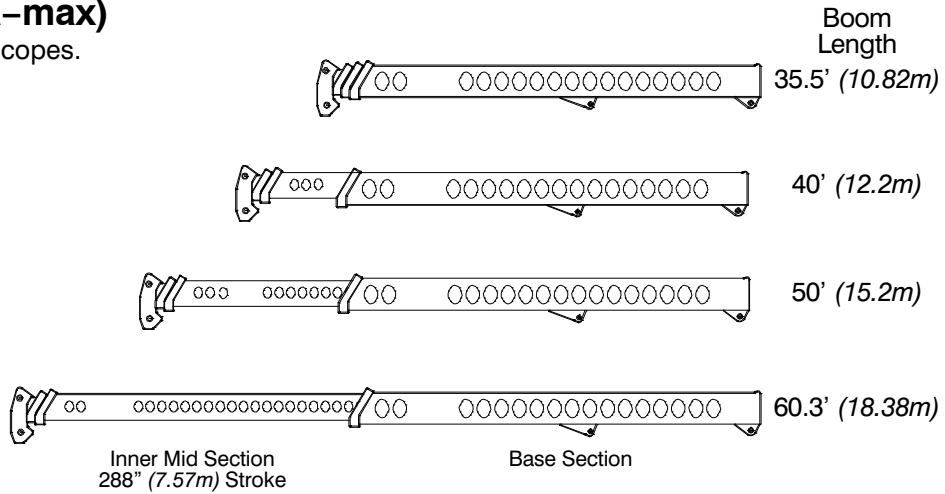

Boom Mode "B" (Standard)

Inner mid, outer mid, and tip sections telescope simultaneously.

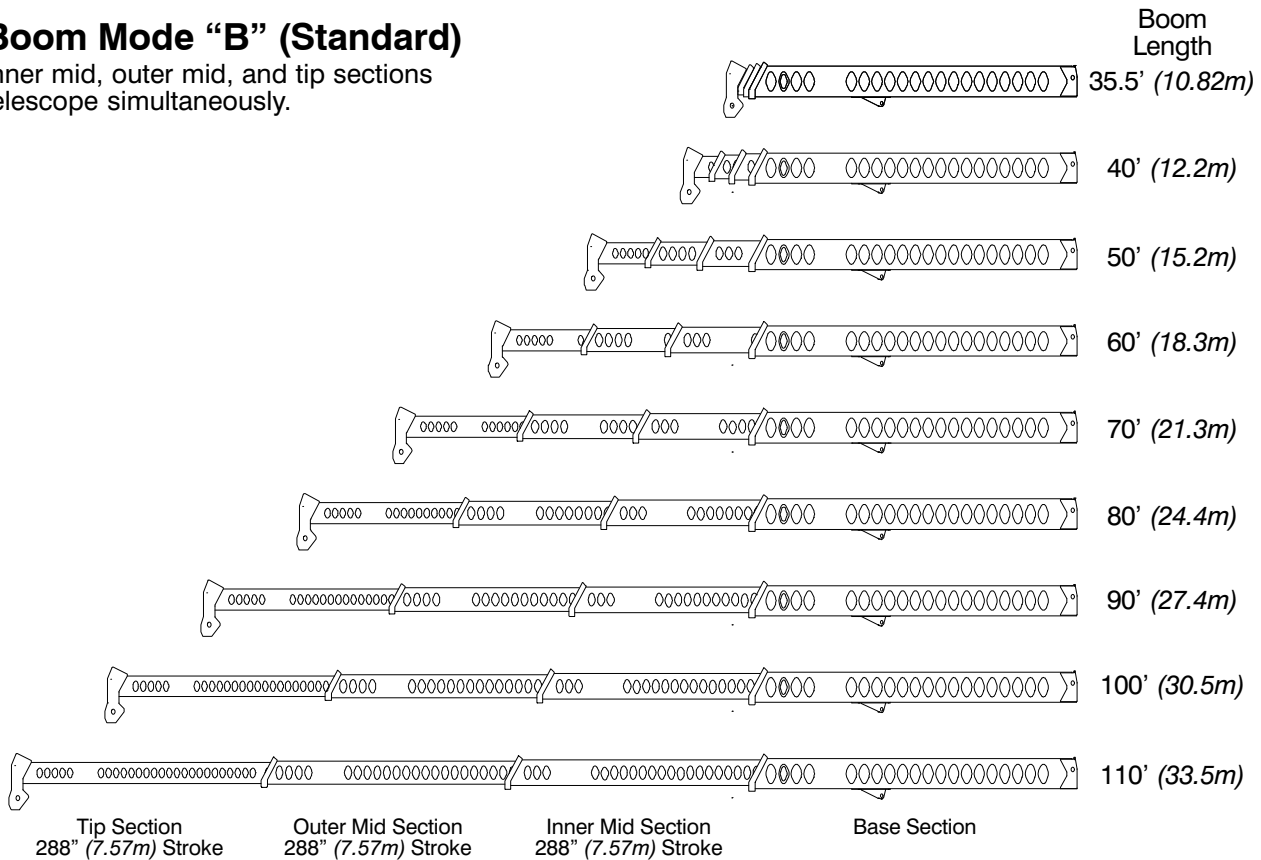



Attachments

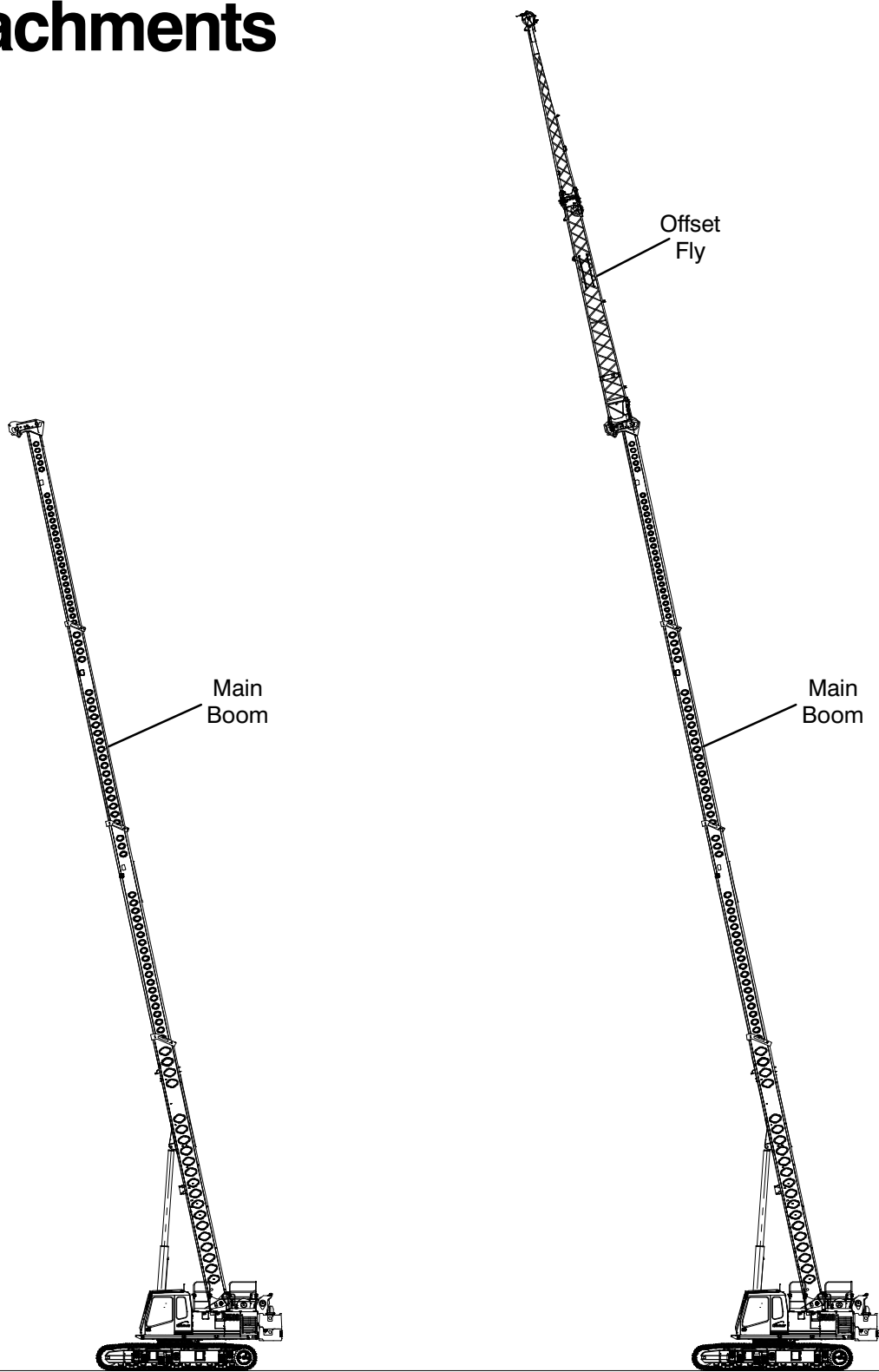

**35.5–110 ft (10.82–33.53m)
Main Boom**

**35.5–110 ft (10.82–33.53m) Main Boom
With 28.5–51 ft (8.69–15.54m) Offset Fly**



Main Boom Working Range Diagrams

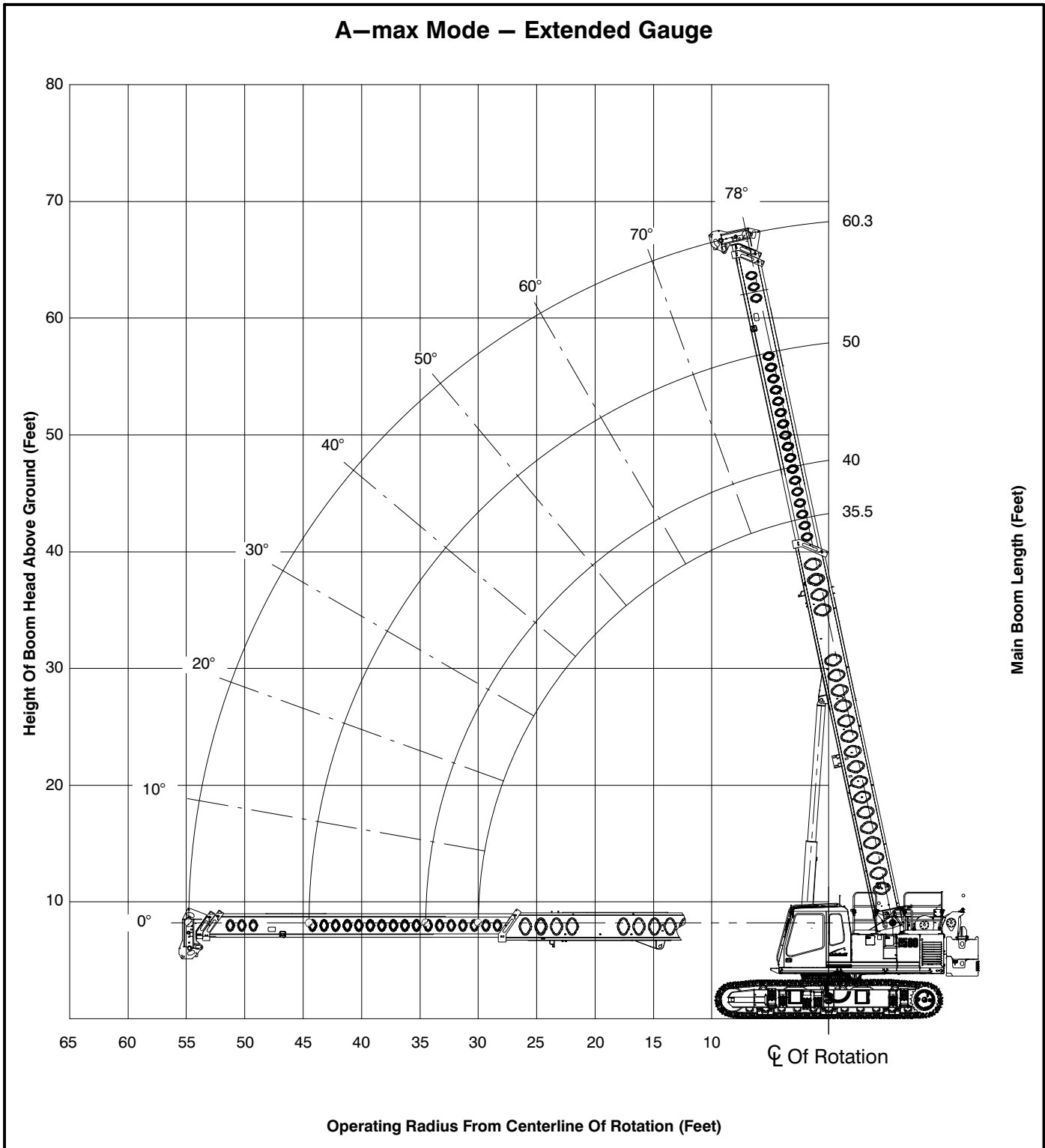

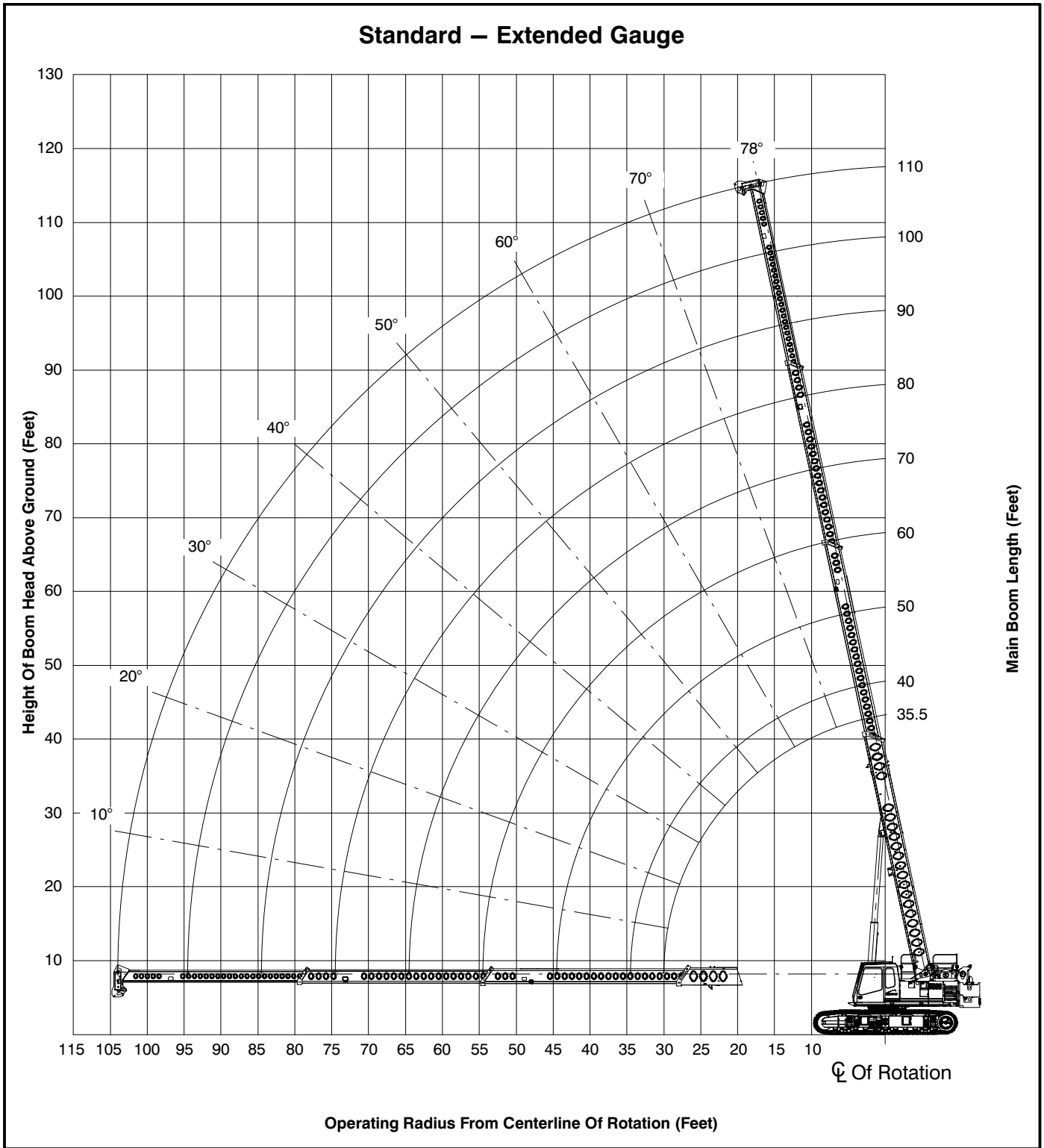



Main Boom + Fly Working Range Diagrams

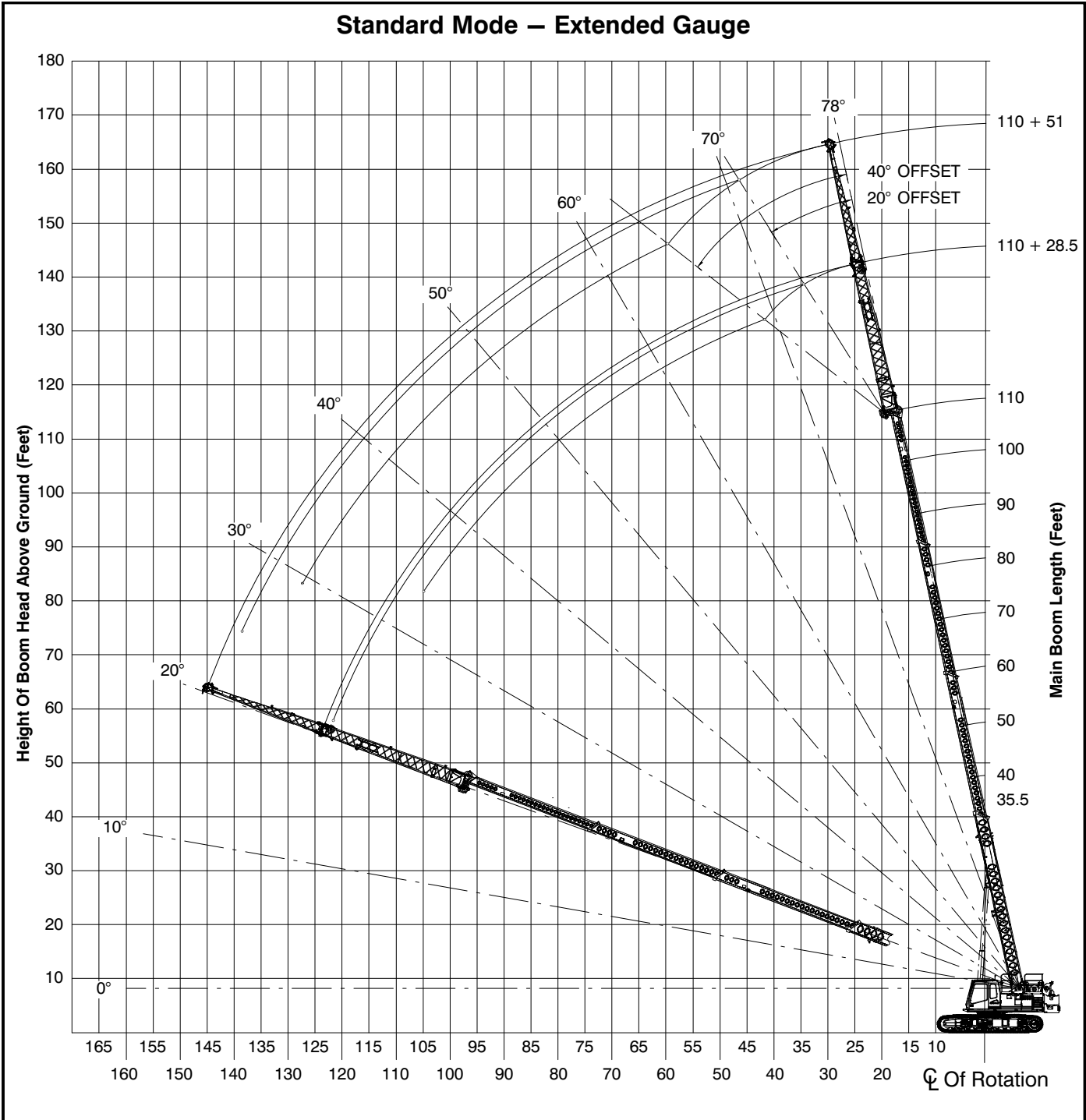



Main Boom Load Charts

| Main Boom Lift Capacity Chart – 360° Rotation – Side Frames Extended Position AB+0 [25,000 lb (11 340kg)] Counterweight [All capacities are listed in kips (mt)] | | | | | | | | | | |
|--|--------------------|----------------|----------------|----------------|----------------|----------------|----------------|-----------------|-----------------|-----------------------|
| Load Radius ft (m) | Boom Length ft (m) | | | | | | | | | Load Radius ft (m) |
| | 35.5 (10.8) | 40.0 (12.2) | 50.0 (15.2) | 60.0 (18.3) | 70.0 (21.3) | 80.0 (24.4) | 90.0 (27.4) | 100.0 (30.5) | 110.0 (33.5) | |
| 10.0 (3.0) | 100.0 (45.4) | 84.0 (38.1) | 82.1 (37.2) | | | | | | | 10.0 (3.0) |
| 12.0 (3.7) | 88.1 (40.0) | 84.0 (38.1) | 79.0 (35.8) | 53.2 (24.1) | 39.0 (17.7) | | | | | 12.0 (3.7) |
| 15.0 (4.6) | 76.8 (34.8) | 74.5 (33.8) | 69.1 (31.3) | 51.1 (23.2) | 39.0 (17.7) | 40.0 (18.1) | | | | 15.0 (4.6) |
| 20.0 (6.1) | 47.0 (21.3) | 46.8 (21.2) | 46.2 (21.0) | 42.1 (19.1) | 39.0 (17.7) | 37.8 (17.1) | 31.2 (14.2) | | | 20.0 (6.1) |
| 25.0 (7.6) | 32.3 (14.7) | 32.7 (14.8) | 33.3 (15.1) | 33.6 (15.2) | 33.7 (15.3) | 33.2 (15.1) | 27.4 (12.4) | 24.7 (11.2) | 20.0 (9.1) | 25.0 (7.6) |
| 30.0 (9.1) | | 24.2 (11.0) | 24.8 (11.2) | 25.2 (11.4) | 25.3 (11.5) | 25.4 (11.5) | 24.2 (11.0) | 21.7 (9.8) | 19.9 (9.0) | 30.0 (9.1) |
| 35.0 (10.7) | | | 19.3 (8.8) | 19.7 (8.9) | 19.9 (9.0) | 20.0 (9.1) | 20.1 (9.1) | 19.4 (8.8) | 17.8 (8.1) | 35.0 (10.7) |
| 40.0 (12.2) | | | 15.4 (7.0) | 15.8 (7.2) | 16.0 (7.3) | 16.2 (7.3) | 16.3 (7.4) | 16.3 (7.4) | 16.0 (7.3) | 40.0 (12.2) |
| 45.0 (13.7) | | | | 12.9 (5.9) | 13.2 (6.0) | 13.3 (6.0) | 13.4 (6.1) | 13.5 (6.1) | 13.5 (6.1) | 45.0 (13.7) |
| 50.0 (15.2) | | | | 10.7 (4.9) | 11.0 (5.0) | 11.2 (5.1) | 11.2 (5.1) | 11.3 (5.1) | 11.3 (5.1) | 50.0 (15.2) |
| 55.0 (16.8) | | | | | 9.2 (4.2) | 9.4 (4.3) | 9.5 (4.3) | 9.6 (4.4) | 9.7 (4.4) | 55.0 (16.8) |
| 60.0 (18.3) | | | | | 7.8 (3.5) | 8.0 (3.6) | 8.1 (3.7) | 8.2 (3.7) | 8.3 (3.8) | 60.0 (18.3) |
| 65.0 (19.8) | | | | | | 6.8 (3.1) | 6.9 (3.1) | 7.0 (3.2) | 7.1 (3.2) | 65.0 (19.8) |
| 70.0 (21.3) | | | | | | 5.8 (2.6) | 5.9 (2.7) | 6.0 (2.7) | 6.1 (2.8) | 70.0 (21.3) |
| 75.0 (22.9) | | | | | | | 5.1 (2.3) | 5.2 (2.4) | 5.2 (2.4) | 75.0 (22.9) |
| 80.0 (24.4) | | | | | | | 4.3 (2.0) | 4.4 (2.0) | 4.5 (2.0) | 80.0 (24.4) |
| 85.0 (25.9) | | | | | | | | 3.8 (1.7) | 3.9 (1.8) | 85.0 (25.9) |
| 90.0 (27.4) | | | | | | | | 3.2 (1.5) | 3.3 (1.5) | 90.0 (27.4) |
| 95.0 (29.0) | | | | | | | | | 2.8 (1.3) | 95.0 (29.0) |
| 100.0 (30.5) | | | | | | | | | 2.4 (1.1) | 100.0 (30.5) |

* 51 metric ton base rating obtained @ 2.5 meters

This material is supplied for reference use only. Operator must refer to in-cab Crane Rating Manual and Operator's Manual to determine allowable crane lifting capacities and assembly and operating procedures.



| Main Boom Lift Capacity Chart – 360° Rotation – Side Frames Intermediate Position ABC+A [36,000 lb (16 329kg)] Counterweight [All capacities are listed in kips (mt)] | | | | | | | | | | |
|--|--------------------|----------------|----------------|----------------|----------------|----------------|----------------|-----------------|-----------------|--------------------------|
| Load Radius ft (m) | Boom Length ft (m) | | | | | | | | | Load Radius ft (m) |
| | 35.5 (10.8) | 40.0 (12.2) | 50.0 (15.2) | 60.0 (18.3) | 70.0 (21.3) | 80.0 (24.4) | 90.0 (27.4) | 100.0 (30.5) | 110.0 (33.5) | |
| 10.0 (3.0) | 100.0 (45.4) | 84.0 (38.1) | 82.1 (37.2) | | | | | | | 10.0 (3.0) |
| 12.0 (3.7) | 88.1 (40.0) | 84.0 (38.1) | 79.0 (35.8) | 53.2 (24.1) | 39.0 (17.7) | | | | | 12.0 (3.7) |
| 15.0 (4.6) | 76.8 (34.8) | 74.5 (33.8) | 69.1 (31.3) | 51.1 (23.2) | 39.0 (17.7) | 40.0 (18.1) | | | | 15.0 (4.6) |
| 20.0 (6.1) | 54.4 (24.7) | 54.2 (24.6) | 53.6 (24.3) | 42.1 (19.1) | 39.0 (17.7) | 37.8 (17.1) | 31.2 (14.2) | | | 20.0 (6.1) |
| 25.0 (7.6) | 37.6 (17.1) | 38.1 (17.3) | 38.5 (17.5) | 38.5 (17.5) | 39.0 (17.7) | 33.2 (15.1) | 27.4 (12.4) | 24.7 (11.2) | 20.0 (9.1) | 25.0 (7.6) |
| 30.0 (9.1) | | 28.4 (12.9) | 29.1 (13.2) | 29.4 (13.3) | 29.6 (13.4) | 29.6 (13.4) | 24.2 (11.0) | 21.7 (9.8) | 19.9 (9.0) | 30.0 (9.1) |
| 35.0 (10.7) | | | 22.8 (10.3) | 23.1 (10.5) | 23.4 (10.6) | 23.4 (10.6) | 21.4 (9.7) | 19.4 (8.8) | 17.8 (8.1) | 35.0 (10.7) |
| 40.0 (12.2) | | | 18.4 (8.3) | 18.8 (8.5) | 19.0 (8.6) | 19.2 (8.7) | 19.2 (8.7) | 17.4 (7.9) | 16.0 (7.3) | 40.0 (12.2) |
| 45.0 (13.7) | | | | 15.5 (7.0) | 15.8 (7.2) | 15.9 (7.2) | 16.0 (7.3) | 15.7 (7.1) | 14.4 (6.5) | 45.0 (13.7) |
| 50.0 (15.2) | | | | 13.0 (5.9) | 13.2 (6.0) | 13.4 (6.1) | 13.5 (6.1) | 13.6 (6.2) | 13.1 (5.9) | 50.0 (15.2) |
| 55.0 (16.8) | | | | | 11.3 (5.1) | 11.4 (5.2) | 11.5 (5.2) | 11.6 (5.3) | 11.7 (5.3) | 55.0 (16.8) |
| 60.0 (18.3) | | | | | 9.7 (4.4) | 9.8 (4.4) | 10.0 (4.5) | 10.1 (4.6) | 10.1 (4.6) | 60.0 (18.3) |
| 65.0 (19.8) | | | | | | 8.5 (3.9) | 8.6 (3.9) | 8.7 (3.9) | 8.8 (4.0) | 65.0 (19.8) |
| 70.0 (21.3) | | | | | | 7.4 (3.4) | 7.5 (3.4) | 7.6 (3.4) | 7.7 (3.5) | 70.0 (21.3) |
| 75.0 (22.9) | | | | | | | 6.5 (2.9) | 6.6 (3.0) | 6.7 (3.0) | 75.0 (22.9) |
| 80.0 (24.4) | | | | | | | 5.7 (2.6) | 5.8 (2.6) | 5.9 (2.7) | 80.0 (24.4) |
| 85.0 (25.9) | | | | | | | | 5.1 (2.3) | 5.1 (2.3) | 85.0 (25.9) |
| 90.0 (27.4) | | | | | | | | 4.4 (2.0) | 4.5 (2.0) | 90.0 (27.4) |
| 95.0 (29.0) | | | | | | | | | 3.9 (1.8) | 95.0 (29.0) |
| 100.0 (30.5) | | | | | | | | | 3.4 (1.5) | 100.0 (30.5) |

This material is supplied for reference use only. Operator must refer to in-cab Crane Rating Manual and Operator's Manual to determine allowable crane lifting capacities and assembly and operating procedures.



Main Boom + Fly Load Charts

| 90 ft (27.4m) Main Boom + Fly – 360° Rotation – Standard Mode – Side Frames Extended Position AB+0 [25,000 lb (11 340kg)] Counterweight [All capacities are listed in kips (mt)] | | | | | | | |
|--|----------------------------|---------------|--------------|-------------------------|--------------|--------------|-----------------------|
| Load Radius ft (m) | 28.25 ft Manual Offset Fly | | | 51 ft Manual Offset Fly | | | Load Radius ft (m) |
| | 2° | 20° | 40° | 2° | 20° | 40° | |
| 30 (9.1) | 16.7 (7.6) | | | | | | 30 (9.1) |
| 35 (10.7) | 15.5 (7.0) | | | 9.7 (4.4) | | | 35 (10.7) |
| 40 (12.2) | 14.5 (6.6) | 10.5 (4.8) | | 8.6 (3.9) | | | 40 (12.2) |
| 45 (13.7) | 13.5 (6.1) | 9.9 (4.5) | 7.9 (3.6) | 8.1 (3.7) | | | 45 (13.7) |
| 50 (15.2) | 12.0 (5.4) | 9.4 (4.3) | 7.6 (3.4) | 7.5 (3.4) | 5.4 (2.4) | | 50 (15.2) |
| 55 (16.8) | 10.4 (4.7) | 8.9 (4.0) | 7.4 (3.4) | 7.0 (3.2) | 5.1 (2.3) | | 55 (16.8) |
| 60 (18.3) | 8.9 (4.0) | 8.7 (3.9) | 7.2 (3.3) | 6.5 (2.9) | 4.9 (2.2) | | 60 (18.3) |
| 65 (19.8) | 7.7 (3.5) | 8.2 (3.7) | 7.0 (3.2) | 6.1 (2.8) | 4.6 (2.1) | 3.7 (1.7) | 65 (19.8) |
| 70 (21.3) | 6.7 (3.0) | 7.2 (3.3) | 6.8 (3.1) | 5.7 (2.6) | 4.4 (2.0) | 3.5 (1.6) | 70 (21.3) |
| 75 (22.9) | 5.9 (2.7) | 6.2 (2.8) | 6.5 (2.9) | 5.4 (2.4) | 4.2 (1.9) | 3.4 (1.5) | 75 (22.9) |
| 80 (24.4) | 5.1 (2.3) | 5.5 (2.5) | 5.7 (2.6) | 5.1 (2.3) | 4.0 (1.8) | 3.3 (1.5) | 80 (24.4) |
| 85 (25.9) | 4.5 (2.0) | 4.8 (2.2) | 4.9 (2.2) | 4.8 (2.2) | 3.9 (1.8) | 3.3 (1.5) | 85 (25.9) |
| 90 (27.4) | 3.9 (1.8) | 4.1 (1.9) | 4.3 (2.0) | 4.4 (2.0) | 3.7 (1.7) | 3.2 (1.5) | 90 (27.4) |
| 95 (29.0) | 3.4 (1.5) | 3.6 (1.6) | 3.7 (1.7) | 3.9 (1.8) | 3.6 (1.6) | 3.1 (1.4) | 95 (29.0) |
| 100 (30.5) | 2.9 (1.3) | 3.1 (1.4) | | 3.4 (1.5) | 3.5 (1.6) | 3.1 (1.4) | 100 (30.5) |
| 105 (32.0) | 2.5 (1.1) | 2.6 (1.2) | | 3.0 (1.4) | 3.4 (1.5) | 3.1 (1.4) | 105 (32.0) |
| 110 (33.5) | 2.2 (1.0) | | | 2.7 (1.2) | 3.0 (1.4) | 3.0 (1.4) | 110 (33.5) |
| 115 (35.1) | | | | 2.3 (1.0) | 2.6 (1.2) | 2.7 (1.2) | 115 (35.1) |
| 120 (36.6) | | | | 2.0 (0.9) | 2.2 (1.0) | | 120 (36.6) |
| 125 (38.1) | | | | 1.8 (0.8) | 1.9 (0.9) | | 125 (38.1) |
| 130 (39.6) | | | | 1.5 (0.7) | 1.6 (0.7) | | 130 (39.6) |
| 135 (41.1) | | | | 1.3 (0.6) | | | 135 (41.1) |

This material is supplied for reference use only. Operator must refer to in-cab Crane Rating Manual and Operator's Manual to determine allowable crane lifting capacities and assembly and operating procedures.



| 110 ft (33.5m) Main Boom + Fly – 360° Rotation – Standard Mode – Side Frames Extended Position AB+0 [25,000 lb (11 340kg)] Counterweight [All capacities are listed in kips (mt)] | | | | | | | |
|--|----------------------------|--------------|--------------|-------------------------|--------------|--------------|-----------------------|
| Load Radius ft (m) | 28.25 ft Manual Offset Fly | | | 51 ft Manual Offset Fly | | | Load Radius ft (m) |
| | 2° | 20° | 40° | 2° | 20° | 40° | |
| 35 (10.7) | 11.5 (5.2) | | | | | | 35 (10.7) |
| 40 (12.2) | 11.5 (5.2) | | | | | | 40 (12.2) |
| 45 (13.7) | 10.9 (4.9) | 9.8 (4.4) | | 6.6 (3.0) | | | 45 (13.7) |
| 50 (15.2) | 10.0 (4.5) | 9.0 (4.1) | 7.5 (3.4) | 6.6 (3.0) | | | 50 (15.2) |
| 55 (16.8) | 9.2 (4.2) | 8.4 (3.8) | 7.4 (3.4) | 6.6 (3.0) | | | 55 (16.8) |
| 60 (18.3) | 8.5 (3.9) | 7.8 (3.5) | 7.2 (3.2) | 6.4 (2.9) | 4.9 (2.2) | | 60 (18.3) |
| 65 (19.8) | 7.6 (3.4) | 7.3 (3.3) | 6.9 (3.1) | 6.1 (2.8) | 4.7 (2.1) | | 65 (19.8) |
| 70 (21.3) | 6.6 (3.0) | 6.8 (3.1) | 6.5 (2.9) | 5.6 (2.5) | 4.5 (2.0) | | 70 (21.3) |
| 75 (22.9) | 5.7 (2.6) | 6.1 (2.8) | 6.1 (2.8) | 5.3 (2.4) | 4.3 (2.0) | 3.5 (1.6) | 75 (22.9) |
| 80 (24.4) | 5.0 (2.3) | 5.4 (2.4) | 5.7 (2.6) | 4.9 (2.2) | 4.1 (1.9) | 3.4 (1.5) | 80 (24.4) |
| 85 (25.9) | 4.3 (2.0) | 4.7 (2.1) | 4.9 (2.2) | 4.6 (2.1) | 4.0 (1.8) | 3.3 (1.5) | 85 (25.9) |
| 90 (27.4) | 3.8 (1.7) | 4.1 (1.9) | 4.3 (2.0) | 4.2 (1.9) | 3.9 (1.8) | 3.2 (1.5) | 90 (27.4) |
| 95 (29.0) | 3.3 (1.5) | 3.5 (1.6) | 3.7 (1.7) | 3.7 (1.7) | 3.7 (1.7) | 3.2 (1.5) | 95 (29.0) |
| 100 (30.5) | 2.8 (1.3) | 3.0 (1.4) | 3.2 (1.5) | 3.2 (1.5) | 3.6 (1.6) | 3.1 (1.4) | 100 (30.5) |
| 105 (32.0) | 2.4 (1.1) | 2.6 (1.2) | 2.7 (1.2) | 2.8 (1.3) | 3.2 (1.5) | 3.1 (1.4) | 105 (32.0) |
| 110 (33.5) | 2.0 (0.9) | 2.2 (1.0) | 2.3 (1.0) | 2.4 (1.1) | 2.8 (1.3) | 3.0 (1.4) | 110 (33.5) |
| 115 (35.1) | 1.7 (0.8) | 1.8 (0.8) | | 2.1 (1.0) | 2.5 (1.1) | 2.7 (1.2) | 115 (35.1) |
| 120 (36.6) | 1.4 (0.6) | 1.5 (0.7) | | 1.8 (0.8) | 2.1 (1.0) | 2.3 (1.0) | 120 (36.6) |
| 125 (38.1) | 1.1 (0.5) | 1.2 (0.5) | | 1.5 (0.7) | 1.8 (0.8) | 2.0 (0.9) | 125 (38.1) |
| 130 (39.6) | | | | 1.3 (0.6) | 1.5 (0.7) | 1.6 (0.7) | 130 (39.6) |
| 135 (41.1) | | | | 1.0 (0.5) | 1.2 (0.5) | 1.3 (0.6) | 135 (41.1) |

This material is supplied for reference use only. Operator must refer to in-cab Crane Rating Manual and Operator's Manual to determine allowable crane lifting capacities and assembly and operating procedures.



| 90 ft (27.4m) Main Boom + Fly – 360° Rotation – Standard Mode – Side Frames Extended Position ABC+A [36,000 lb (16 329kg)] Counterweight [All capacities are listed in kips (mt)] | | | | | | | |
|--|----------------------------|---------------|--------------|-------------------------|--------------|--------------|-----------------------|
| Load Radius ft (m) | 28.25 ft Manual Offset Fly | | | 51 ft Manual Offset Fly | | | Load Radius ft (m) |
| | 2° | 20° | 40° | 2° | 20° | 40° | |
| 30 (9.1) | 16.7 (7.6) | | | | | | 30 (9.1) |
| 35 (10.7) | 15.5 (7.0) | | | 9.7 (4.4) | | | 35 (10.7) |
| 40 (12.2) | 14.5 (6.6) | 10.5 (4.8) | | 8.6 (3.9) | | | 40 (12.2) |
| 45 (13.7) | 13.5 (6.1) | 9.9 (4.5) | 7.9 (3.6) | 8.1 (3.7) | | | 45 (13.7) |
| 50 (15.2) | 12.4 (5.6) | 9.4 (4.3) | 7.6 (3.4) | 7.5 (3.4) | 5.4 (2.4) | | 50 (15.2) |
| 55 (16.8) | 11.4 (5.2) | 8.9 (4.0) | 7.4 (3.4) | 7.0 (3.2) | 5.1 (2.3) | | 55 (16.8) |
| 60 (18.3) | 10.5 (4.8) | 8.7 (3.9) | 7.2 (3.3) | 6.5 (2.9) | 4.9 (2.2) | | 60 (18.3) |
| 65 (19.8) | 9.4 (4.3) | 8.3 (3.8) | 7.0 (3.2) | 6.1 (2.8) | 4.6 (2.1) | 3.7 (1.7) | 65 (19.8) |
| 70 (21.3) | 8.3 (3.8) | 8.0 (3.6) | 6.8 (3.1) | 5.7 (2.6) | 4.4 (2.0) | 3.5 (1.6) | 70 (21.3) |
| 75 (22.9) | 7.3 (3.3) | 7.7 (3.5) | 6.7 (3.0) | 5.4 (2.4) | 4.2 (1.9) | 3.4 (1.5) | 75 (22.9) |
| 80 (24.4) | 6.5 (2.9) | 6.8 (3.1) | 6.6 (3.0) | 5.1 (2.3) | 4.0 (1.8) | 3.3 (1.5) | 80 (24.4) |
| 85 (25.9) | 5.7 (2.6) | 6.0 (2.7) | 6.2 (2.8) | 4.8 (2.2) | 3.9 (1.8) | 3.3 (1.5) | 85 (25.9) |
| 90 (27.4) | 5.1 (2.3) | 5.3 (2.4) | 5.5 (2.5) | 4.5 (2.0) | 3.7 (1.7) | 3.2 (1.5) | 90 (27.4) |
| 95 (29.0) | 4.5 (2.0) | 4.7 (2.1) | 4.8 (2.2) | 4.3 (2.0) | 3.6 (1.6) | 3.1 (1.4) | 95 (29.0) |
| 100 (30.5) | 4.0 (1.8) | 4.2 (1.9) | | 4.1 (1.9) | 3.5 (1.6) | 3.1 (1.4) | 100 (30.5) |
| 105 (32.0) | 3.5 (1.6) | 3.7 (1.7) | | 3.9 (1.8) | 3.4 (1.5) | 3.1 (1.4) | 105 (32.0) |
| 110 (33.5) | 3.1 (1.4) | | | 3.6 (1.6) | 3.3 (1.5) | 3.0 (1.4) | 110 (33.5) |
| 115 (35.1) | | | | 3.3 (1.5) | 3.2 (1.5) | 3.0 (1.4) | 115 (35.1) |
| 120 (36.6) | | | | 2.9 (1.3) | 3.1 (1.4) | 3.0 (1.4) | 120 (36.6) |
| 125 (38.1) | | | | 2.6 (1.2) | 2.8 (1.3) | | 125 (38.1) |
| 130 (39.6) | | | | 2.3 (1.0) | 2.4 (1.1) | | 130 (39.6) |
| 135 (41.1) | | | | 2.0 (0.9) | | | 135 (41.1) |

This material is supplied for reference use only. Operator must refer to in-cab Crane Rating Manual and Operator's Manual to determine allowable crane lifting capacities and assembly and operating procedures.



| 110 ft (33.5m) Main Boom + Fly – 360° Rotation – Standard Mode – Side Frames Extended Position ABC+A [36,000 lb (16 329kg)] Counterweight [All capacities are listed in kips (mt)] | | | | | | | |
|--|----------------------------|--------------|--------------|-------------------------|--------------|--------------|-----------------------|
| Load Radius ft (m) | 28.25 ft Manual Offset Fly | | | 51 ft Manual Offset Fly | | | Load Radius ft (m) |
| | 2° | 20° | 40° | 2° | 20° | 40° | |
| 35 (10.7) | 11.5 (5.2) | | | | | | 35 (10.7) |
| 40 (12.2) | 11.5 (5.2) | | | | | | 40 (12.2) |
| 45 (13.7) | 10.9 (4.9) | 9.8 (4.4) | | 6.6 (3.0) | | | 45 (13.7) |
| 50 (15.2) | 10.0 (4.5) | 9.0 (4.1) | 7.5 (3.4) | 6.6 (3.0) | | | 50 (15.2) |
| 55 (16.8) | 9.2 (4.2) | 8.4 (3.8) | 7.4 (3.4) | 6.6 (3.0) | | | 55 (16.8) |
| 60 (18.3) | 8.5 (3.9) | 7.8 (3.5) | 7.2 (3.3) | 6.4 (2.9) | 4.9 (2.2) | | 60 (18.3) |
| 65 (19.8) | 7.8 (3.5) | 7.3 (3.3) | 6.9 (3.1) | 6.1 (2.8) | 4.7 (2.1) | | 65 (19.8) |
| 70 (21.3) | 7.3 (3.3) | 6.8 (3.1) | 6.5 (2.9) | 5.6 (2.5) | 4.5 (2.0) | | 70 (21.3) |
| 75 (22.9) | 6.8 (3.1) | 6.4 (2.9) | 6.1 (2.8) | 5.3 (2.4) | 4.3 (2.0) | 3.5 (1.6) | 75 (22.9) |
| 80 (24.4) | 6.3 (2.9) | 6.0 (2.7) | 5.8 (2.6) | 4.9 (2.2) | 4.1 (1.9) | 3.4 (1.5) | 80 (24.4) |
| 85 (25.9) | 5.6 (2.5) | 5.7 (2.6) | 5.5 (2.5) | 4.6 (2.1) | 4.0 (1.8) | 3.3 (1.5) | 85 (25.9) |
| 90 (27.4) | 4.9 (2.2) | 5.3 (2.4) | 5.2 (2.4) | 4.3 (2.0) | 3.9 (1.8) | 3.2 (1.5) | 90 (27.4) |
| 95 (29.0) | 4.4 (2.0) | 4.7 (2.1) | 4.8 (2.2) | 4.1 (1.9) | 3.7 (1.7) | 3.2 (1.5) | 95 (29.0) |
| 100 (30.5) | 3.9 (1.8) | 4.1 (1.9) | 4.3 (2.0) | 3.8 (1.7) | 3.6 (1.6) | 3.1 (1.4) | 100 (30.5) |
| 105 (32.0) | 3.4 (1.5) | 3.6 (1.6) | 3.7 (1.7) | 3.5 (1.6) | 3.4 (1.5) | 3.1 (1.4) | 105 (32.0) |
| 110 (33.5) | 3.0 (1.4) | 3.2 (1.5) | 3.2 (1.5) | 3.2 (1.5) | 3.2 (1.5) | 3.0 (1.4) | 110 (33.5) |
| 115 (35.1) | 2.6 (1.2) | 2.8 (1.3) | | 2.9 (1.3) | 3.0 (1.4) | 2.9 (1.3) | 115 (35.1) |
| 120 (36.6) | 2.3 (1.0) | 2.4 (1.1) | | 2.6 (1.2) | 2.8 (1.3) | 2.8 (1.3) | 120 (36.6) |
| 125 (38.1) | 2.0 (0.9) | 2.0 (0.9) | | 2.3 (1.0) | 2.5 (1.1) | 2.6 (1.2) | 125 (38.1) |
| 130 (39.6) | | | | 2.1 (1.0) | 2.3 (1.0) | 2.4 (1.1) | 130 (39.6) |
| 135 (41.1) | | | | 1.8 (0.8) | 2.0 (0.9) | 2.1 (1.0) | 135 (41.1) |

This material is supplied for reference use only. Operator must refer to in-cab Crane Rating Manual and Operator's Manual to determine allowable crane lifting capacities and assembly and operating procedures.



This Page Intentionally Blank



5646-0314-S5

Link-Belt Construction Equipment Company Lexington, Kentucky www.linkbelt.com

®Link-Belt is a registered trademark. Copyright 2014. We are constantly improving our products and therefore reserve the right to change designs and specifications.