



Technical Data

Specifications & Capacities

HTC
8690
LB

Telescopic Boom Truck Crane
90 US ton
81.6 metric ton

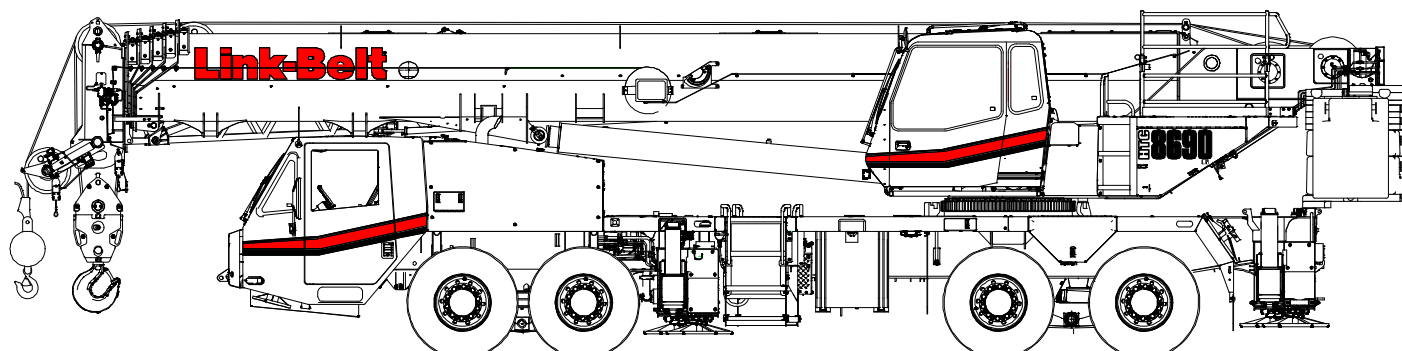

CAUTION: This material is supplied for reference use only. Operator must refer to in-cab Crane Rating Manual and Operator's Manual to determine allowable crane lifting capacities and assembly and operating procedures.



5759-0416-T2LB



Table Of Contents

Boom, Attachments, and Upper Structure	1
Boom	1
Boom Wear Pads	1
Boom Head	1
Boom Elevation	1
Auxiliary Lifting Sheave – Optional	1
Hook Blocks and Balls – Optional	1
Fly – Optional	1
Fly Extensions – Optional	1
Upper Operator’s Cab and Controls	2
Swing	3
Electrical	3
Load Hoist System	3
Load Hoist Performance	3
2M Main and Optional Auxiliary Winches	3
Hydraulic System	4
Counterweight	4
Carrier	6
General	6
Outriggers	6
Steering and Axles	6
Suspension	6
Tires and Wheels	6
Brakes	6
Electrical	6
Engine	6
Transmission	6
Carrier Speeds and Gradeability	7
Fuel Tank	7
Hydraulic System	7
Pump Drive	7
Lower Cab and Controls	8
Additional Equipment	8
Axle Loads	9
Axle Loads with 2–Axle or 3– Axle Boom Dolly	10
General Dimensions	11
EPA 2013	11
Tier 3 / Stage IIIA	12
Working Range Diagram	13
Main Boom + 10’ (3.0m) Fly	13



5759-0416-T2LB

Main Boom + Attachments	14
Boom Extend Modes	15
Main Boom Lift Capacity Charts – Imperial B30.5 – Standard	16
8,000 lb Counterweight – Fully Extended Outriggers – 360° Rotation	16
16,000 lb Counterweight – Fully Extended Outriggers – 360° Rotation	17
Main Boom Lift Capacity Charts – Imperial B30.5 – Optional	18
24,000 lb Counterweight – Fully Extended Outriggers – 360° Rotation	18
36,000 lb Counterweight – Fully Extended Outriggers – 360° Rotation	19
48,600 lb Counterweight – Fully Extended Outriggers – 360° Rotation	20
Manual Offset Fly Lift Capacity Charts – Imperial B30.5 – Optional	21
8,000 lb Counterweight – Fully Extended Outriggers – 360° Rotation	21
Main Boom +10 ft Manual Offset Fly (0°, 15°, 30°, 45° Offsets)	21
16,000 lb Counterweight – Fully Extended Outriggers – 360° Rotation	22
Main Boom +10 ft Manual Offset Fly (0°, 15°, 30°, 45° Offsets)	22
24,000 lb Counterweight – Fully Extended Outriggers – 360° Rotation	23
Main Boom +10 ft Manual Offset Fly (0°, 15°, 30°, 45° Offsets)	23
36,000 lb Counterweight – Fully Extended Outriggers – 360° Rotation	24
Main Boom +10 ft Manual Offset Fly (0°, 15°, 30°, 45° Offsets)	24
48,600 lb Counterweight – Fully Extended Outriggers – 360° Rotation	25
Main Boom +10 ft Manual Offset Fly (0°, 15°, 30°, 45° Offsets)	25
8,000 lb Counterweight – Fully Extended Outriggers – 360° Rotation	26
164.1 ft Main Boom Length + 35 ft & 58 ft Manual Offset Fly (0°–45° offsets)	26
16,000 lb Counterweight – Fully Extended Outriggers – 360° Rotation	27
164.1 ft Main Boom Length + 35 ft & 58 ft Manual Offset Fly (0°–45° offsets)	27
164.1 ft Main Boom Length + 74 ft & 90 ft Manual Offset Fly (0°–45° offsets)	27
24,000 lb Counterweight – Fully Extended Outriggers – 360° Rotation	28
164.1 ft Main Boom Length + 35 ft & 58 ft Manual Offset Fly (0°–45° offsets)	28
164.1 ft Main Boom Length + 74 ft & 90 ft Manual Offset Fly (0°–45° offsets)	29
36,000 lb Counterweight – Fully Extended Outriggers – 360° Rotation	30
164.1 ft Main Boom Length + 35 ft & 58 ft Manual Offset Fly (0°–45° offsets)	30
164.1 ft Main Boom Length + 74 ft & 90 ft Manual Offset Fly (0°–45° offsets)	31
48,600 lb Counterweight – Fully Extended Outriggers – 360° Rotation	32
164.1 ft Main Boom Length + 35 ft & 58 ft Manual Offset Fly (0°–45° offsets)	32
164.1 ft Main Boom Length + 74 ft & 90 ft Manual Offset Fly (0°–45° offsets)	33



Boom, Attachments, and Upper Structure

■ Boom

Design —Six section, formed construction of extra high tensile steel consisting of one base section and five telescoping sections. The two plate design of each section has multiple longitudinal bends for superior strength. Each telescoping section extends independently by means of one double-acting, single stage hydraulic cylinder with integrated holding valves.

Boom

- 38.3–164.1 ft (11.7–50.0m) six section boom
- Integral boom dolly connection
- Six boom extend modes (EM1 through EM6), controlled from the operator's cab, provide superior capacities by varying the extension of the telescoping sections:
 - EM1 extends to 164.1 ft (50.0m)
 - EM2 extends to 152.4 ft (46.5m)
 - EM3 extends to 140.3 ft (42.7m)
 - EM4 extends to 126.3 ft (38.5m)
 - EM5 extends to 114.6 ft (34.9m)
 - EM6 extends to 89.5 ft (27.3m)
- Mechanical boom angle indicator
- Maximum tip height for each extend mode is:
 - EM1 is 173 ft (52.6m)
 - EM2 is 161 ft (49.1m)
 - EM3 is 149 ft (45.5m)
 - EM4 is 136 ft (41.3m)
 - EM5 is 124 ft (37.8m)
 - EM6 is 99 ft (30.2m)

Boom Wear Pads

- Wear pads with Teflon inserts that self-lubricate the boom sections
- Bottom wear pads are universal for all boom sections
- Top wear pads are universal for all boom sections

Boom Head

- Five 16.5 in (41.9cm) root diameter nylon sheaves to handle up to ten parts of line
- Easily removable wire rope guards
- Rope dead end lugs on each side of the boom head
- Boom head is designed for quick-reeve of the hook block
- Wind speed indicator
- Aviation obstruction marking light and flag – optional

Boom Elevation

- One double acting hydraulic cylinder with integral holding valve
- Boom elevation: -3° to 80°

Auxiliary Lifting Sheave – Optional

- Single 16.5 in (41.9cm) root diameter nylon sheave
- Easily removable wire rope guards
- Does not affect erection of the fly or use of the main head sheaves

Hook Blocks and Balls – Optional

- 25 ton (22.7mt) 1 sheave quick-reeve hook block with safety latch
- 60 ton (54.4mt) 3 sheave quick-reeve hook block with safety latch
- 80 ton (72.5mt) 5 sheave quick-reeve hook block with safety latch
- 110 ton (100mt) 6 sheave quick-reeve hook block with safety latch
- 10 ton (9.1mt) swivel and non-swivel hook balls with safety latch

Fly – Optional

- 10 ft (3.0m) one piece lattice fly, stowable, offsettable to 0° , 15° , 30° , and 45° . Maximum tip height is 181 ft (55.2m).
- 10 ft–35 ft (3.0m–10.7m) two piece lattice fly, stowable, offsettable to 0° , 15° , 30° , and 45° . Maximum tip height is 206 ft (62.7m).
- 10 ft–35 ft–58 ft (3.0m–10.7m–17.7m) three piece lattice fly, stowable, offsettable to 0° , 15° , 30° , and 45° . Maximum tip height is 230 ft (70.2m).

Fly Extensions – Optional

- One 16 ft (4.9m) lattice extension to be mounted between the boom head and fly options. Maximum tip height is 246 ft (75.0m).
- Two 16 ft (4.9m) lattice extensions to be mounted between the boom head and fly options. Maximum tip height is 262 ft (79.7m).



■ Upper Operator's Cab and Controls

Environmental Cab – Fully enclosed, one person cab of galvanneal steel structure with acoustical insulation.

Equipped with:

- Tilting cab up to 20°
- Tinted and tempered glass windows
- Extra—large fixed front window with windshield wiper and washer
- Swing up roof window with windshield wiper
- Sliding left side door with large fixed window
- Sliding rear and right side windows for ventilation
- Six way adjustable, cushioned seat with seat belt and storage compartment
- Diesel fired warm—water heater with air ducts for front windshield defroster and cab floor
- Defroster fan for the front window
- Bubble level
- Circulating fan
- Adjustable sun visor
- LED Dome lights
- Cup holder
- Fire extinguisher
- Left side viewing mirror
- Pull—out cabwalk
- Two position travel swing lock
- AM/FM Radio

Air Conditioning – Integral with cab heating system utilizing the same ventilation outlets

Armrest Controls – Two dual axis electronic joystick controllers or optional single axis electronic controllers for:

- Swing
- Boom hoist
- Main rear winch
- Auxiliary front winch – optional
- Drum rotation indication
- Drum rotation indicator activation switch
- Swing park brake switch
- Winch high/low speed and disable switch(es)
- Counterweight handling switch
- Warning horn button
- Cab heater and A/C controls
- Cab tilt switch
- Throttle lock switch
- Throttle set/resume switch
- PTO enable switch
- Remote controlled boom floodlight – optional

Outrigger Controls – Hand held control box with umbilical cord gives the operator the freedom to view operation while setting the outriggers.

Foot Controls

- Boom telescope
- Swing brake
- Engine throttle

Right Front Console – Controls and indicators for:

- Engine ignition
- Function disable
- Front windshield wiper and washer
- Cab floodlights
- Warning horn
- Console dimmer switch
- Emergency engine shutdown
- Boom floodlight – optional
- Rotating beacon or strobe Light – optional
- 2–12 volt accessory outlets (switched and unswitched)

Camera Display – Located on dash console

- Displays right side of upper
- Displays main and auxiliary winches

Cab Instrumentation – Ergonomically positioned LCD display, CANBUS instrumentation for crane operation including:

- Tachometer
- Engine water temperature
- Fuel level
- Hydraulic oil temperature
- Stop engine
- Check engine
- Wait to start
- Regeneration disabled light (EPA 2013 engine only)
- DPF regeneration light (EPA 2013 engine only)
- High exhaust temperature light (EPA 2013 engine only)
- Malfunction indicator lamp (EPA 2013 engine only)
- Engine air filter high restriction light
- Fine metering function set and percent
- Engine hours
- Third wrap indicator activation and setup
- Electronic control diagnostics
- Engine oil pressure
- Swing park brake light
- Battery voltage
- Fuel rate (gal/hr)
- Engine load
- Engine Diagnostics

Link-Belt Pulse – The Link-Belt in-house designed, total crane operating system that utilizes the display as a readout and operator interface for the following systems:

- **Rated capacity limiter** – LCD graphic audio – visual warning system integrated into the dash with anti – two block and function limiter. Operating data includes:
 - Crane configuration
 - Boom length and angle
 - Boom head height
 - Allowed load and % of allowed load
 - RCL light bar
 - Boom angle
 - Radius of load
 - Actual load
 - Wind speed
 - Highlighted unit of measurement on working screen
 - Active pin/latch status
 - Telescope operation displayed in real time
 - Counterweight installation/removal
 - Third wrap indicator
 - Diagnostics
 - Operator settable alarms (include):
 - Maximum and minimum boom angles
 - Maximum tip height
 - Maximum boom length
 - Swing left/right positions
 - Operator defined area (imaginary plane)
- **Telematics** – Cellular—based data logging and monitoring system that provides:
 - Location and operational settings
 - Routine maintenance
 - Crane and engine monitoring
 - Diagnostic and fault codes
- **Extend control module (ECM)**
 - Controls the extend modes
 - Diagnostics

Integrated First Layer And Third Wrap Indicator

– **Optional** – Link—Belt Pulse color display visually and audibly warns the operator when the wire rope is on the first/bottom layer and when the wire rope is down to the last three wraps.

Integrated First Layer And Third Wrap Function Kickout

– **Optional** – Link—Belt Pulse color display visually and audibly warns the operator when the wire rope is on the first/bottom layer and provides a function kickout when the wire rope is down to the last three wraps.



Diagnostic Center – Located on the left side of the front panel below the windshield.

- Engine diagnostic
- RCL CANBUS diagnostic
- Boom CANBUS diagnostic
- Outrigger CANBUS diagnostic
- Crane controller USB diagnostic
- RCL controller USB diagnostic

Internal RCL Light Bar – Visually informs the operator when crane is approaching maximum load capacity with a series of green, yellow, and red lights.

External RCL Light Bar – Optional – Visually informs the ground crew when crane is approaching maximum load capacity with a series of green, yellow, and red lights.

■ Swing

Motor/Planetary – Bi-directional hydraulic swing motor mounted to a planetary reducer for 360° continuous smooth swing at 1.7 rpm.

Swing Park Brake – 360°, electric over hydraulic, (spring applied/hydraulic released) multi-disc brake mounted on the speed reducer. Operated by a switch from the operator's cab.

Swing Brake – 360°, foot operated, hydraulic applied disc brake mounted to the speed reducer.

Swing Lock – Two-position swing lock (boom over front or rear) operated from the operator's cab.

360° Positive Swing Lock – Optional – Meets New York City requirement.

■ Electrical

Swing Alarm – Audio warning device signals when the upper is swinging.

Lights

- Two working lights on front of the cab
- One amber strobe beacon on top of the cab – optional
- Boom floodlight – Single – optional – One high intensity floodlight mounted at the front portion of the boom base section. Adjustable to fixed positions.
- Boom floodlight – Dual – optional – Two high intensity floodlights mounted at the front portion of the boom base section. Two adjustable to individual fixed positions.
- Boom floodlight package – optional – Three high intensity floodlights mounted at the front portion of the boom base section. Two adjustable to individual fixed positions and one remote controlled.
- Work lighting package – optional – Four high intensity work lights mounted on top of the operator's cab, the right side of the superstructure facing forward, on the upper work platform, and on the left side of the superstructure facing down

■ Load Hoist System

Load Hoist Performance

Main (Rear) and Auxiliary (Front) Winches – 19mm (3/4 in) Rope										
Layer	Maximum Line Pull		Normal Line Speed		High Line Speed		Layer		Total	
	lb	kN	ft/min	m/min	ft/min	m/min	ft	m	ft	m
1	20,739	92.25	185	56.4	367	111.9	114	34.7	114	34.7
2	19,066	84.80	201	61.3	399	121.6	124	37.8	238	72.5
3	17,644	78.48	217	66.1	431	131.4	134	40.8	372	113.4
4	16,419	73.03	233	71.0	463	141.1	144	43.9	516	157.3
5	15,353	68.29	250	76.2	495	150.9	154	46.9	670	204.2
6	---	---	---	---	---	---	164	50.0	834	254.2

Wire Rope Application		Diameter		Type	Maximum Permissible Load	
		in	mm		lb	kN
Main (Rear) Winch	Standard	3/4	19	37x7 non rotating – right lang lay (Type KC)	16,000	71.17
	Optional	3/4	19	35x7 non rotating – right lang lay (Type CC)	17,160	76.33
	Optional	3/4	19	34x7 non rotating – right lang lay (Type YB)	16,000	71.17
Auxiliary (Front) Winch	Standard	3/4	19	37x7 non rotating – right lang lay (Type KC)	16,000	71.17
	Optional	3/4	19	35x7 non rotating – right lang lay (Type CC)	17,160	76.33
	Optional	3/4	19	34x7 non rotating – right lang lay (Type YB)	16,000	71.17

2M Main and Optional Auxiliary Winches

- Axial piston, full and half displacement (2-speed) motors driven through planetary reduction unit for positive control under all load conditions.
- Grooved lagging
- Power up/down mode of operation
- Hoist drum cable follower – optional
- Drum rotation indicator
- Drum diameter: 16 in (40.6cm)
- Rope length:
 - Main: 730 ft (222.5m)
 - Auxiliary: 600 ft (182.9m) or 730 ft (222.5m)
- Maximum rope storage: 834 ft (254.2m)
- Terminator style socket and wedge



■ Hydraulic System

All circuits of the hydraulic system are pressure compensated.

Counterbalance Valves – All hoist motors, boom extend cylinders, and boom hoist cylinders are equipped with counterbalance valves to provide load lowering and to prevent accidental load drop if hydraulic power is suddenly reduced.

Hydraulic Oil Cooler – One carrier mounted cooler removes heat from the hydraulic oil. The cooler is mounted in left side access ladder.

Boom Hoist Float Valves (Optional) – For transporting the boom over the rear of the crane with a boom dolly. Allows hydraulic oil within the boom hoist cylinder to flow between piston side and case side, allowing the boom to float while on the boom dolly.

Swing Brake Release – For transporting the boom over the rear of the crane with a boom dolly. Holds the 360° swing park brake in the released position allowing free rotation of the upper structure.

■ Counterweight

Standard – Total of 16,000 lb (7.2t) of total counterweight consisting of four, hydraulically removable counterweights. Assembled and disassembled by hydraulic cylinders controlled from the operator's cab with capacities for:

- 0 lb (0t) counterweight
- 4,000 lb (1.8t) counterweight
- 8,000 lb (3.6t) counterweight
- 12,000 lb (5.4t) counterweight
- 16,000 lb (7.2t) counterweight

Optional – 20,000 lb (9t) in addition to standard counterweight for a total of 36,000 lb (16.2t) with additional capacities for:

- 20,000 lb (9t) counterweight
- 24,000 lb (10.8t) counterweight
- 28,000 lb (12.7t) counterweight
- 32,000 lb (14.4t) counterweight
- 36,000 lb (16.2t) counterweight

Optional – 32,600 lb (14.8t) in addition to standard counterweight for a total of 48,600 lb (22t) with additional capacities for:

- 20,000 lb (9t) counterweight
- 24,000 lb (10.8t) counterweight
- 28,000 lb (12.7t) counterweight
- 32,000 lb (14.4t) counterweight
- 36,000 lb (16.2t) counterweight
- 48,600 lb (22t) counterweight*

Low speed jobsite travel is offered for these optional counterweight configurations and a boom dolly or boom trailer may be required for on-highway travel.

* Overall width of the crane increases to 13 ft 10.8 in (4.24m) for this counterweight configuration

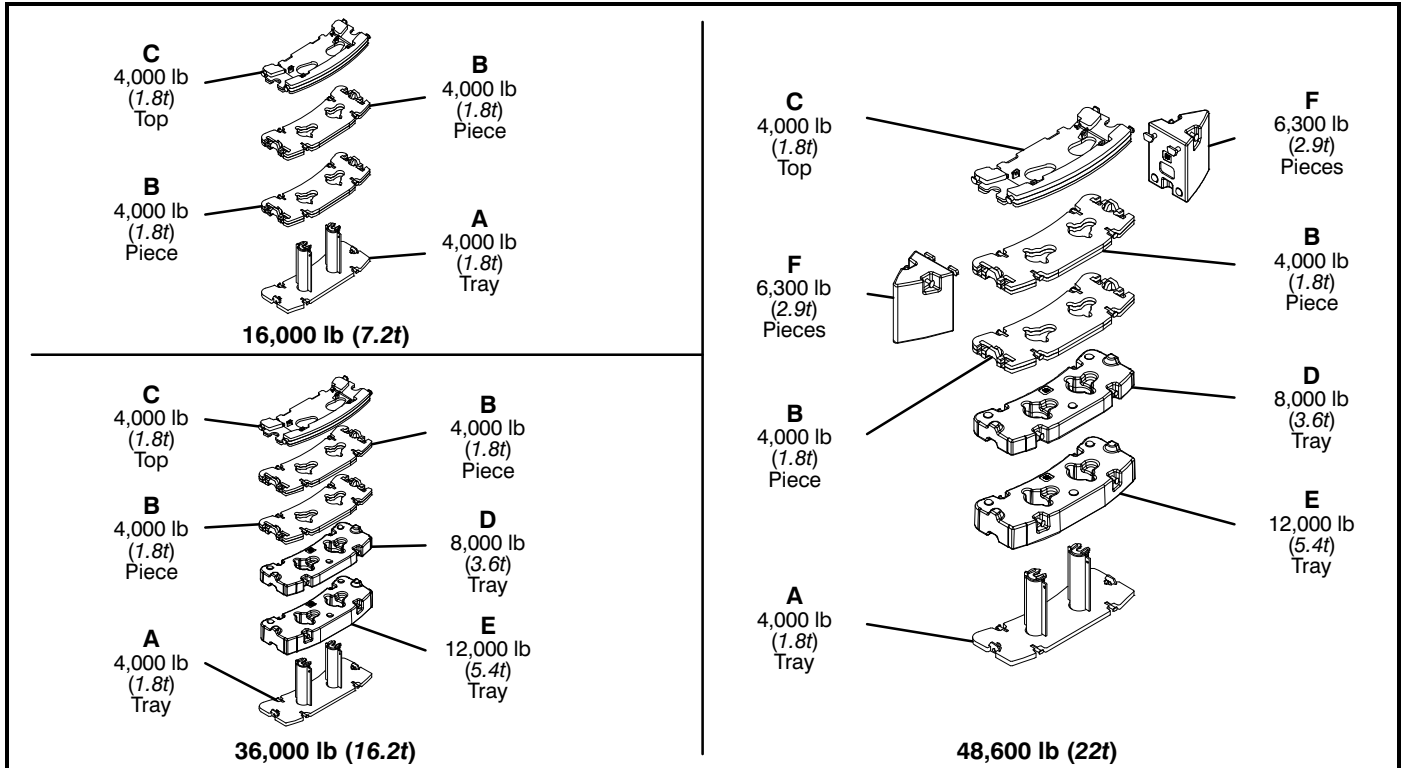

Counterweight Packages			16,000 (7.2t) – Standard							
			36,000 (16.2t) – Optional							
Counterweight Pieces			48,600 (22.0t) – Optional							
			A	B	B	C	D	E	F	F
			4,000 lb (1.8t) Piece	4,000 lb (1.8t) Piece	4,000 lb (1.8t) Piece	4,000 lb (1.8t) Piece	8,000 lb (3.6t) Piece	12,000 lb (5.4t) Piece	6,300 lb (2.9t) Piece	6,300 lb (2.9t) Piece
Counterweight Configurations		0 lb (0t)								
	A	4,000 lb (1.8t)	X							
	A,B	8,000 lb (3.6t)	X	X						
	A,B,C	12,000 lb (5.4t)	X	X	X					
	A,B,B,C	16,000 lb (7.2t)	X	X	X	X				
	A,B,C,D	20,000 lb (9t)	X	X	X		X			
	A,B,B,C,D	24,000 lb (10.8t)	X	X	X	X	X			
	A,B,B,C,E	28,000 lb (12.7t)	X	X	X	X		X		
	A,B,C,D,E	32,000 lb (14.4t)	X	X	X		X	X		
	A,B,B,C,D,E	36,000 lb (16.2t)	X	X	X	X	X	X		
	A,B,B,C,D,E,F,F	48,600 lb (22t)	X	X	X	X	X	X	X	X



Carrier

General

- 8 ft 6 in (2.6m) wide
- 23 ft 5 in (7.14m) wheelbase (centerline of first axle to centerline of fourth axle)
- **Frame** – Box-type, torsion resistant, welded construction made of high tensile steel. Equipped with front and rear towing and tie-down lugs, tow connections, and access ladders.

Outriggers

Boxes – Two double box, front and rear welded to the carrier frame

Beams and Jacks – Four dual stage beams with Confined Area Lifting Capacities (CALC) provide selectable outrigger extensions of full, intermediate, and retracted positions. Jacks with integral check valves, hydraulically controlled from the operator's cab and on both sides of carrier. A fifth front bumper outrigger 16 in (40.64cm) diameter, self-storing with integral check valves is hydraulically controlled from the operator's cab and at the front bumper of carrier.

Pontoons

- **Main** – Four lightweight, stow'n go, 23.5" x 27.25" (59.7 x 69.2cm) hexagonal steel pontoons with a contact area of 485 in² (3 129cm²) can be stored for road travel in either the storage racks on the carrier or under the outrigger boxes
- **Front Bumper** – One, lightweight, self-storing, 16" (40.6cm) diameter steel pontoon with a contact area of 201 in² (1 296cm²)

Jack Reaction

- **Main** – 106,000 lb (471.5kN) force and 231 psi (1 593kPa) ground bearing pressure
- **Front Bumper** – 54,000 lb (240.2kN) force and 269 psi (1 855kPa) ground bearing pressure

Steering and Axles

- Dual gear steering system provides hydraulic assisted steering with mechanical link between steering wheel and wheels
- **Drive** – 8 x 4 for on/off-highway travel
- **Axle 1 & 2** – Tandem steered, non-driven
- **Axle 3 & 4** – Tandem non-steered, driven with reduction: 5.38 to 1
- **Inter-Axle Differential Lock** – Locks axle 3 with axle 4. Operated by a switch from the carrier cab.

Suspension

Front – Walking beam air suspension

Rear – Walking beam air suspension

- **Axle Lift System – Optional** – Improves rear tire ground clearance when the crane is up on outriggers. The axle lift system can be controlled with a switch on both sides of the carrier.

Tires and Wheels

Front – Four (single) 445/65R22.5 tires on aluminum disc wheels

Rear – Eight (dual) 315/80R22.5 tires on aluminum disc wheels

- Spare tires and wheels – optional
- Tire inflation kit – optional

Brakes

Service – Full air anti-lock (ABS) brakes on all wheel ends. Dual circuit compressed air system with air dryer.

Parking/Emergency – Spring loaded type, acting on 2nd, 3rd, and 4th axles automatically apply when air pressure drops below 60 psi (413.7kPa) in both circuits.

Electrical

Battery – Three batteries provide 12 volt starting and operation

Lights

- Front lighting includes two main daytime running/headlights, two high beam lights, two parking/directional indicators, and three cab marker lights.
- Side lighting includes three parking/directional indicators per side.
- Rear lighting includes two parking/directional indicators, two parking/brake lights, two reverse lights, three marker lights, and a license plate light.
- Other equipment includes hazard/warning system, cab light, instrument panel light, and signal horn.
- One amber strobe beacon behind the cab
- Compartment lighting inside storage boxes, outrigger control boxes, and fuel fill.

Engine

Specification	Cummins ISX12	Cummins QSX15
Emissions Compliance Level:	EPA 2013 (1)	Tier 3/ Stage IIIA (2)
Maximum Allowable Sulfur Content of Fuel (PPM):	15	5000
Numbers of cylinders:	6	6
Cycle:	4	4
Bore and Stroke: inch (mm)	5.11 x 5.91 (130x150)	5.39 x 6.65 (137x169)
Piston Displacement: in ³ (L)	729 (11.9)	915 (15.0)
Max. Brake Horsepower: hp (kW)	450 (336) @ 1,800 rpm 414 (309) @ 2,100 rpm	480 (358.8) @ 1,800 rpm 450 (336) @ 2,100 rpm
Peak Torque: ft lb (Nm)	1,550 (2 102) @ 1,200 rpm	1,550 (2 102) @ 1,400 rpm
Alternator: volts – amps	12 – 145	12 – 135
Crankcase Capacity: qt (L)	48 (45.4)	48.0 (45.4)

- Cruise control
- Cummins ISX12 Three stage engine compression brake
- Thermostatically controlled, hydraulically driven radiator fan
- 120 volt engine block heater – ISX
- Ether injection system – optional on ISX
- Grid heater starting aid standard on QSX and ISX
- 220 volt engine block heater – QSX15
- Engine equipped with on-board diagnostics – ISX
- Cummins QSX15 Two stage compression brake

(1) Can only be sold and/or operated where EPA2013 on-highway emission standards are accepted.

(2) Can only be sold and/or operated where Tier 3/Stage IIIA off-highway emission standards are accepted.

Transmission

Automated – ZF AS-TRONIC (no clutch pedal) manual transmission with 12 forward gears and 2 reverse gears.



Carrier Speeds and Gradeability

ZF Astronic		Governed Speed				Gradeability (@ Peak Torque Except Creep @ Idle)		
		EPA 2013		Tier 3/Stage IIIA		% Grade		
Gear	Ratio	mph	km/h	mph	km/h	EPA 2013	Tier 3/ Stage IIIA	
						12th	0.78	62
11th	1.00	48	78	48	78	2.6	2.6	
10th	1.27	38	61	38	61	3.7	3.7	
9th	1.63	30	48	30	48	5.1	5.1	
8th	2.10	23	37	23	37	6.8	6.8	
7th	2.70	18	29	18	29	9.0	9.0	
6th	3.55	14	22	14	22	12.2	12.1	
5th	4.57	11	17	11	17	15.8	15.8	
4th	5.78	8	13	8	13	20.3	20.2	
3rd	7.44	6	10	6	10	26.2	26.1	
2nd	9.59	5	8	5	8	34.0	33.9	
1st	12.33	4	6	4	6	43.9	43.7	
Reverse 1		11.41	4	7	4	7	40.6	40.4
Reverse 2		8.88	5	9	5	9	31.5	31.3
Creep @ idle	2nd	9.59	2	3	2	3	15.9	20.5
	1st	12.33	1	2	1	2	20.7	26.6
	Reverse 1	11.41	1	2	1	2	19.1	24.5
	Reverse 2	8.88	2	3	2	3	14.7	18.9

Based on a gross vehicle weight of 107,250 lb (48 647.8kg)

Fuel Tank

- One 95 gal (359.6L) capacity tank
- One 10 gal (37.8L) capacity diesel exhaust fluid (DEF) plastic tank (EPA 2013 engine only)

Hydraulic System

All functions are hydraulically powered allowing positive, precise control with independent or simultaneous operation of all functions.

Main Pumps

- Three fixed displacement gear pumps with automatic disconnect for the main and auxiliary winches, swing, boom hoist, control circuit, and telescope for use when pick & carry switch is in travel mode.
- One fixed displacement gear pump for steering
- Two fixed displacement gear pumps for engine cooling fan, front bumper outrigger, and main outriggers. These pumps also provide flow to the winches and boom hoist for "pick & carry" mode. Operated by a switch in the carrier cab.
- Combined pump capacity of 188 gpm (711.7Lpm)

Hydraulic Reservoir – 144 gal (545.1L) capacity equipped with sight level gauge. Diffusers built in for deaeration.

Filtration – One 10 micron, full flow, return line filter. All oil is filtered prior to return to reservoir. Accessible for easy filter replacement.

Pump Drive

All pumps are mechanically driven by the diesel engine. Main and auxiliary winches, swing, boom hoist, control circuit, and telescope pumps are mounted to an automatic pump disconnect on the rear of the transmission to aid in cold weather starting as well as to reduce pump wear while traveling.



■ Lower Cab and Controls

Environmental Cab – Fully enclosed, one person cab of composite structure with acoustical insulation. Equipped with:

- Tinted and tempered glass windows
- Roll down left side window for ventilation
- Right side window
- Windshield wiper and washer
- Six way adjustable and air suspended driver's seat with seat belt
- Two adjustable rear view mirrors
- Engine dependent warm-water heater with air ducts for windshield defroster and cab floor
- Adjustable sun visor
- Dome light
- 12 volt connection
- Fire extinguisher

Air Conditioning – Integral with cab heating system utilizing the same ventilation outlets

Overhead Console – Located above the sun visor

- Document storage unit
- AM/FM Radio
- 12 volt accessory jack/cigarette lighter (switched)
- 12 volt accessory jack (unswitched)
- Strobe beacon switch

Camera Display – Located on dash console

- Displays right side of machine
- Displays rear view
- Displays rear view of boom trailer – optional

Cab Instrumentation – Ergonomically positioned analog instrumentation for driving including:

- Speedometer with odometer, hourmeter, trip odometer, and clock
- Front and rear air pressure with warning indicator
- Engine coolant temperature with warning indicator
- Engine oil pressure with warning indicator
- Voltage indicator with warning indicator
- Fuel level
- Tachometer
- Diesel exhaust fluid with warning indicator (EPA 2013 engine only)

Right Side Console – Controls and indicators for:

- Transmission gear shifting
- Transmission digital readout
- Cruise controls
- Engine compression brake controls
- 12 volt accessory jack (switched)

Dash Mounted Controls For:

- Carrier lights
- Carrier/upper throttle control
- Engine cooling fan override
- Cab heater/air conditioning
- Console dimmer switch
- Anti-lock brake diagnostic switch
- Diesel particulate filter switch (EPA 2013 engine only)
- Park brake
- Pick & carry switch
- Inter-axle differential lock switch
- Engine ignition (EPA 2013 engine only)

- Air ride suspension switch

Dash Mounted Indicator For:

- Check, stop, and service engine
- Turn signal indication
- Park brake
- Cruise activation
- High beam headlights
- Check anti-lock brake system
- Check anti-lock trailer brake system
- Diesel particulate filter indication (EPA 2013 engine only)
- High exhaust temperature indication (EPA 2013 engine only)
- Regeneration inhibit (EPA 2013 engine only)
- Malfunction indicator lamp (EPA 2013 engine only)
- Axle lock indication
- Wait to start
- Seat belt lock
- Swing brake locked indicator
- Air filter service indicator
- Rear axle offset – optional

Steering Column Controls For:

- Warning horn
- Turn indicators
- High beam headlights
- Steering wheel adjustments
- Intermittent windshield wiper and washer
- Hazard lights

Foot Controls For:

- Carrier service brakes
- Engine throttle

■ Additional Equipment

Standard:

- Aluminum full deck fenders with mud flaps
- Left and right bubble levels
- Air hose connection ports
- Clearance flags
- Four storage compartments
 - Right front fender
 - Right side ladder
 - Storage box between axles 3 and 4 on the left and right sides

Optional:

- Pneumatic and electrical quick disconnect connectors mounted on the rear for trailer or boom dolly brakes and lights
- Rear mounted pintle hook
- Trailer rear view camera



Axle Loads

Base crane with full tank of fuel and no counterweight	Gross Vehicle Weight ⁽¹⁾		Front Axles		Rear Axles	
	lb	kg	lb	kg	lb	kg
	EPA 2013	83,505	37 877	38,006	17 239	45,499
Tier 3/Stage IIIA	83,351	37 807	37,960	17 218	45,390	20 589
Driver in carrier cab	250	113	316	143	-66	-30
Rear pintle hook	13	6	-6	-3	18	8
Pneumatic and electrical connectors for trailer or boom dolly	11	5	-4	-2	16	7
Air ride lift system – rear axles	58	26	0	0	58	26
Ether injection	5	3	4	2	0	0
Hoist drum follower – main	69	31	-36	-16	106	48
Auxiliary winch with 600 ft (182.9m) of 3/4" (19mm) type "KC" rope	674	306	-238	-108	912	414
Hoist drum follower – auxiliary (front)	69	31	-22	-10	92	42
Substitute 600 ft (182.9m) of rope with 730 ft (222.5m) of rope – auxiliary	158	72	-56	-25	214	97
Remove 730 ft (222.5m) of rope from rear (main) winch	-902	-409	382	173	-1,284	-582
Remove 600 ft (182.9m) of rope from front (auxiliary) winch	-744	-337	262	119	-1,006	-456
360° mechanical swing lock	140	64	18	8	122	55
Work lighting package	27	12	2	1	24	11
4,000 lb (1.8t) counterweight bottom tray on upper	4,000	1 814	-2,076	942	6,076	2 756
4,000 lb (1.8t) counterweight on upper	4,000	1 814	-2,076	942	6,076	2 756
4,000 lb (1.8t) counterweight on upper	4,000	1 814	-2,076	942	6,076	2 756
8,000 lb (3.6t) counterweight on upper	8,000	3 629	-4,154	-1 884	12,154	5 512
12,000 lb (5.4t) counterweight on upper	12,000	5 443	-6,230	-2 826	18,230	8 269
4,000 lb (1.8t) top counterweight on upper	4,000	1 814	-2,076	942	6,076	2 756
Floodlight package to the front of boom base section	20	9	24	11	-4	-2
Fly mounting brackets to boom base section for fly options	472	214	363	165	109	49
10 ft (3.0m) lattice fly – stowed	1,345	610	1,994	904	-649	-294
10–35 ft (3.0–10.7m) offsettable, two–piece (bi–fold) lattice fly – stowed	2,377	1 078	2,531	1 148	-154	-70
10–35–58 ft (3.0–10.7–17.7m) offsettable, three–piece (bi–fold) lattice fly – stowed	2,991	1 357	2,838	1,287	152	69
Auxiliary lifting sheave	110	50	204	93	-94	-43
25 ton (22.7mt) 1–sheave hook block at front bumper	750	340	1,330	603	-580	-263
60 ton (54.4mt) 3–sheave hook block at front bumper w/one set of weights	985	447	1,748	793	-762	-346
60 ton (54.4mt) 3–sheave hook block at front bumper w/three sets of weights	1,345	610	2,386	1 082	-1,040	-472
80 ton (73mt) 5–sheave hook block at front bumper	1,406	638	2,494	1 131	-1,088	-494
110 ton (99.8mt) 6–sheave hook block at front bumper	1,985	900	3,520	1 597	-1,536	-697
10 ton (9.1mt) hook ball at front bumper	580	263	1,028	466	-448	-203

Counterweight Load Transfer	Front Axles		Rear Axles	
	lb	kg	lb	kg
Transfer 4,000 lb (1.8t) counterweight to the rear carrier deck	564	256	-564	-256
Transfer 4,000 lb (1.8t) counterweight to the front carrier deck	5,110	2 318	-5,110	-2 318
Transfer 8,000 lb (3.6t) counterweight to the front carrier deck	10,218	4 635	-10,218	-4 635
Transfer 12,000 lb (5.4t) counterweight to the front carrier deck	15,328	6 953	-15,328	-6 953

Axle	Maximum Load @ 65 mph (105km/h)
Front	23,625 lb (10 716kg) – aluminum disc wheels with 445/65R22.5 tires
Rear	30,000 lb (13 608kg) – aluminum disc wheels with 315/80R22.5 tires

(1) Adjust gross vehicle weight and axle loading according to component weight. All weights are ±3%.



Axle Loads with 2-Axle or 3-Axle Boom Dolly

Base crane with full tank of fuel and no counterweight	Gross Vehicle Weight ⁽¹⁾		Front Axles		Rear Axles		Dolly Axles	
	lb	kg	lb	kg	lb	kg	lb	kg
	EPA 2013	83,505	37 877	29,823	13 527	38,237	17 344	15,446
Tier 3/Stage IIIA	83,351	37 807	29,781	13 508	38,126	17 294	15,446	7 006
Nelson 2-axle boom dolly with 4'6" spacing	6,000	2 722	0	0	0	0	6,000	2 722
Nelson 3-axle boom dolly with 4'6" spacing	9,000	4 082	0	0	0	0	9,000	4 082
Driver in carrier cab	250	113	316	143	-66	-30	0	0
Rear pintle hook	13	6	-6	-3	18	8	0	0
Pneumatic and electrical connectors for trailer or boom dolly	11	5	-4	-2	16	7	0	0
Air ride lift system – rear axles	58	26	0	0	58	26	0	0
Ether injection	5	2	4	2	0	0	0	0
Hoist drum follower – main	69	31	52	24	16	7	0	0
Auxiliary winch with 600 ft (182.9m) of 3/4" (19mm) type "KC" rope	674	306	400	181	274	124	0	0
Hoist drum follower – auxiliary (front)	69	31	40	18	30	14	0	0
Substitute 600 ft (182.9m) of rope with 730 ft (222.5m) of rope – auxiliary	158	72	94	43	64	29	0	0
Remove 730 ft (222.5m) of rope from main (rear) winch	-902	-409	-598	271	-304	-138	0	0
Remove 600 ft (182.9m) of rope from auxiliary (front) winch	-744	-337	-440	200	-304	-138	0	0
360° mechanical swing lock	140	64	14	6	126	57	0	0
Work lighting package	27	12	2	1	24	11	0	0
4,000 lb (1.8t) bottom tray counterweight tray on front carrier deck	4,000	1 814	3,032	1 375	968	439	0	0
4,000 lb (1.8t) counterweight on front carrier deck	4,000	1 814	3,032	1 375	968	439	0	0
4,000 lb (1.8t) counterweight on front carrier deck	4,000	1 814	3,032	1 375	968	439	0	0
8,000 lb (3.6t) counterweight on front carrier deck	8,000	3 629	6,064	2 751	1,936	878	0	0
12,000 lb (5.4t) counterweight on front carrier deck	12,000	5 443	9,096	4 126	2,904	1 317	0	0
4,000 lb (1.8t) top counterweight on front upper	4,000	1 814	3,032	1 375	968	439	0	0
Floodlight package to the front of boom base section	20	9	2	1	2	1	17	8
Fly mounting brackets to boom base section for fly options	472	214	91	41	95	43	286	130
10 ft (3.0m) lattice fly – stowed	1,345	610	-19	-9	-20	-9	1,385	628
10–35 ft (3.0–10.7m) offsettable two-piece (bi-fold) lattice fly – stowed	2,377	1 078	254	115	265	120	1,857	842
10–35–58 ft (3.0–10.7–17.7m) offsettable, three-piece (bi-fold) lattice fly – stowed	2,991	1 357	421	191	439	199	2,131	967
Auxiliary lifting sheave	110	50	-20	9	-22	-10	151	68
25 ton (22.7mt) 1-sheave hook block at boom head	750	340	-74	-34	-78	-35	902	409
60 ton (54.4mt) 3-sheave hook block at boom head w/one set of weights	985	447	-98	-44	-102	-46	1,184	537
60 ton (54.4mt) 3-sheave hook block at boom head w/three sets of weights	1,345	610	-266	-121	-278	-126	1,617	733
80 ton (73mt) 5-sheave hook block at boom head	1,406	638	-140	-64	-146	-66	1,690	767
110 ton (99.8mt) 6-sheave hook block at boom head	1,985	900	-196	-89	-204	-93	2,386	1 082
10 ton (9.1mt) hook ball at boom head	580	263	-58	-26	-60	-27	697	316

Counterweight Load Transfer	Front Axles		Rear Axles		Dolly Axles	
	lb	kg	lb	kg	lb	kg
Transfer 4,000 lb (1.8t) counterweight to the boom dolly	-3,032	1 375	-698	-317	4,000	1 814
Transfer 8,000 lb (3.6t) counterweight to the boom dolly	-6,064	2 751	-1,936	-878	8,000	3 629
Transfer 12,000 lb (5.4t) counterweight to the boom dolly	-9,096	4 126	-2,904	-1 317	12,000	5 443

Axle	Maximum Load @ 65 mph 105km/h)
Front	23,625 lb (10 716kg) – aluminum disc wheels with 445/65R22.5 tires
Rear	30,000 lb (13 608kg) – aluminum disc wheels with 315/80R22.5 tires

(1) Adjust gross vehicle weight and axle loading according to component weight. All weights are ±3%.



General Dimensions

EPA 2013

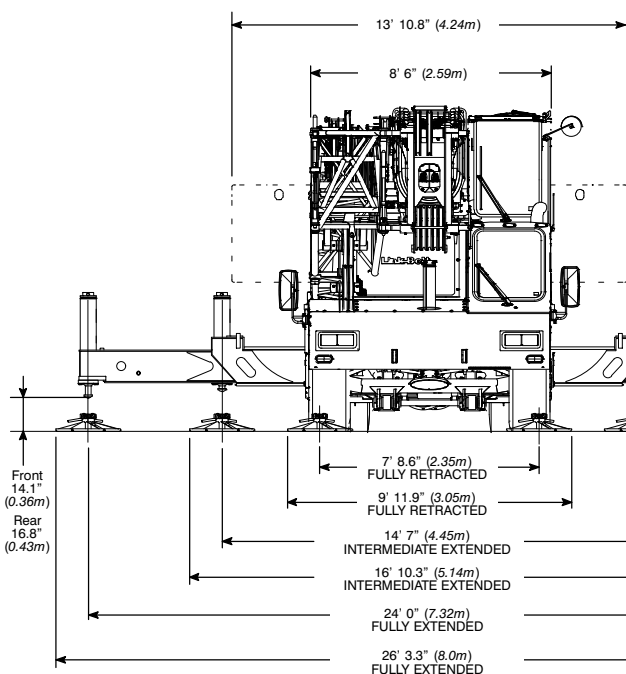
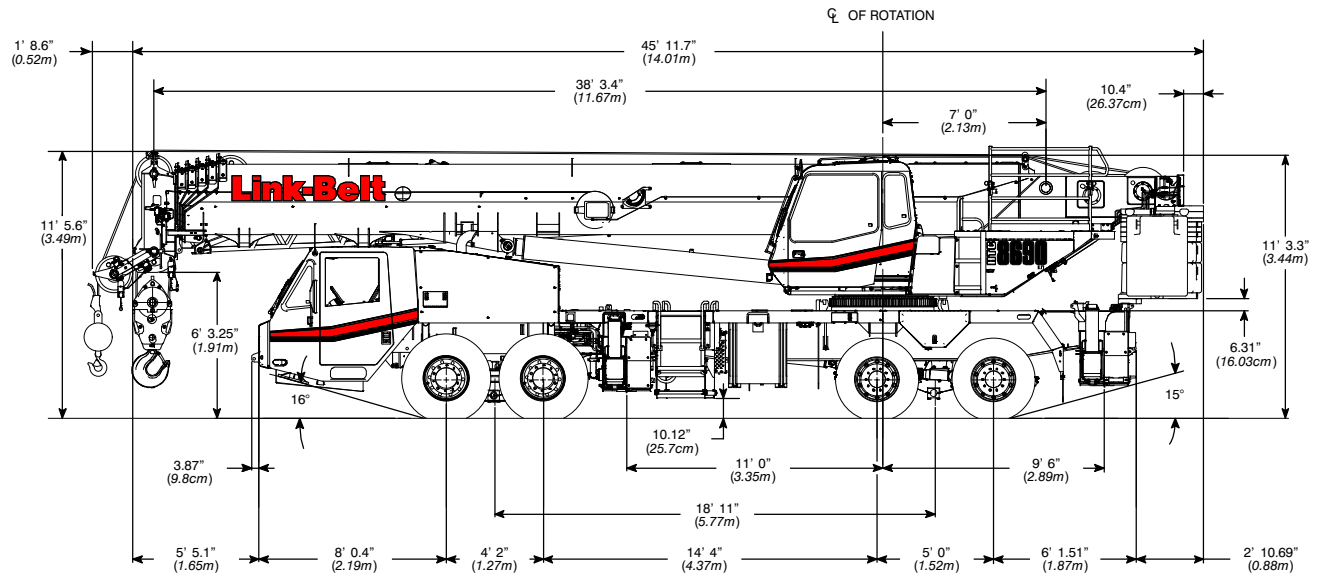

Turning Radius	English	Metric
Wall to wall over carrier	47' 8"	14.8m
Wall to wall over boom	48' 9"	14.9m
Wall to wall over boom attachment	50' 9"	15.5m
Curb to curb	43' 6"	13.3m
Centerline of tire	42' 8"	13.0m

Tail Swing	English	Metric
With counterweight	13' 9"	4.2m
Without counterweight	13' 0"	4.0m

Overall Width	English	Metric
With up to 36,000 lb (16 329.3kg) counterweight	8' 6"	2.6m
With 48,600 lb (22 044.6kg) counterweight	13' 11"	4.2m

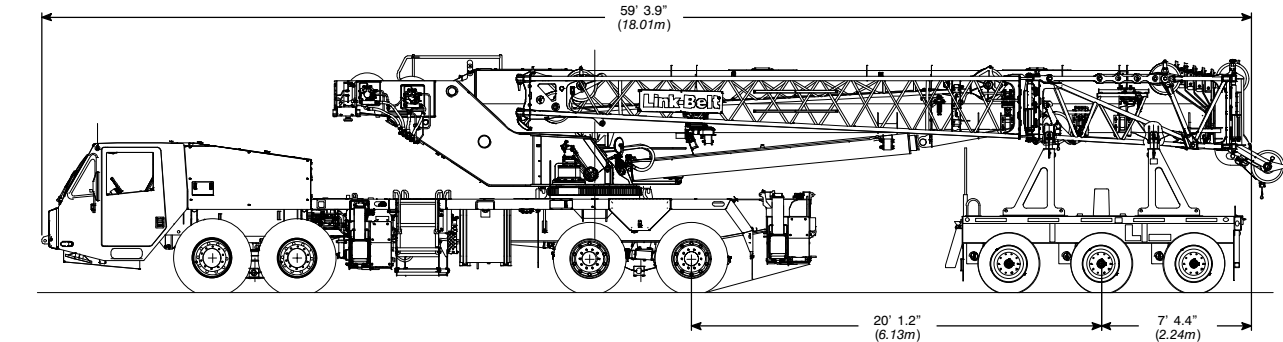

Not To Scale



General Dimensions

Tier 3 / Stage IIIA

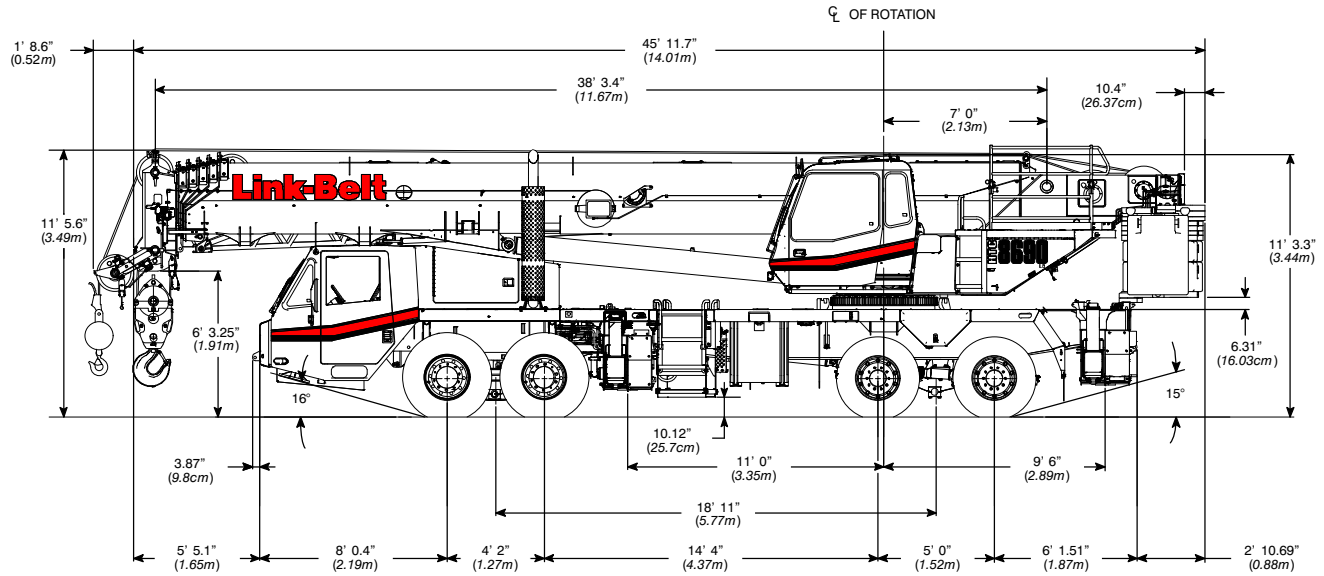

Turning Radius	English	Metric
Wall to wall over carrier	47' 8"	14.8m
Wall to wall over boom	48' 9"	14.9m
Wall to wall over boom attachment	50' 9"	15.5m
Curb to curb	43' 6"	13.3m
Centerline of tire	42' 8"	13.0m

Tail Swing	English	Metric
With counterweight	13' 9"	4.2m
Without counterweight	13' 0"	4.0m

Overall Width	English	Metric
With up to 36,000 lb (16 329.3kg) counterweight	8' 6"	2.6m
With 48,600 lb (22 044.6kg) counterweight	13' 11"	4.2m

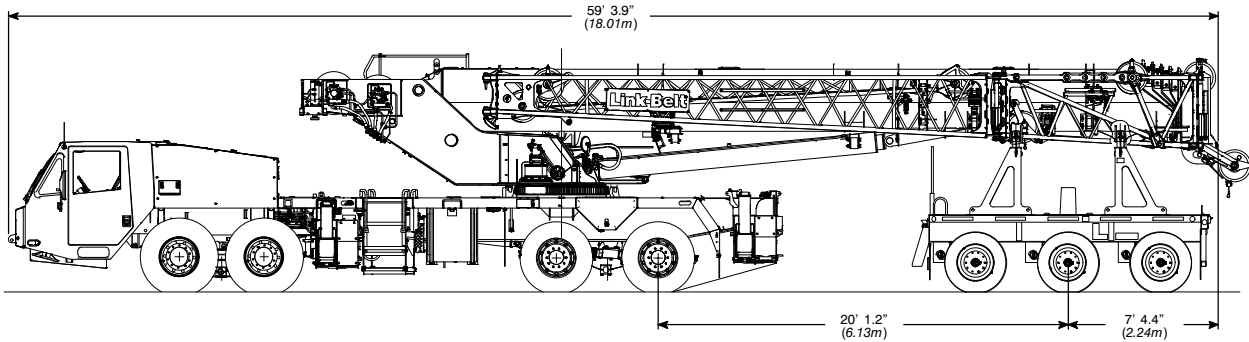
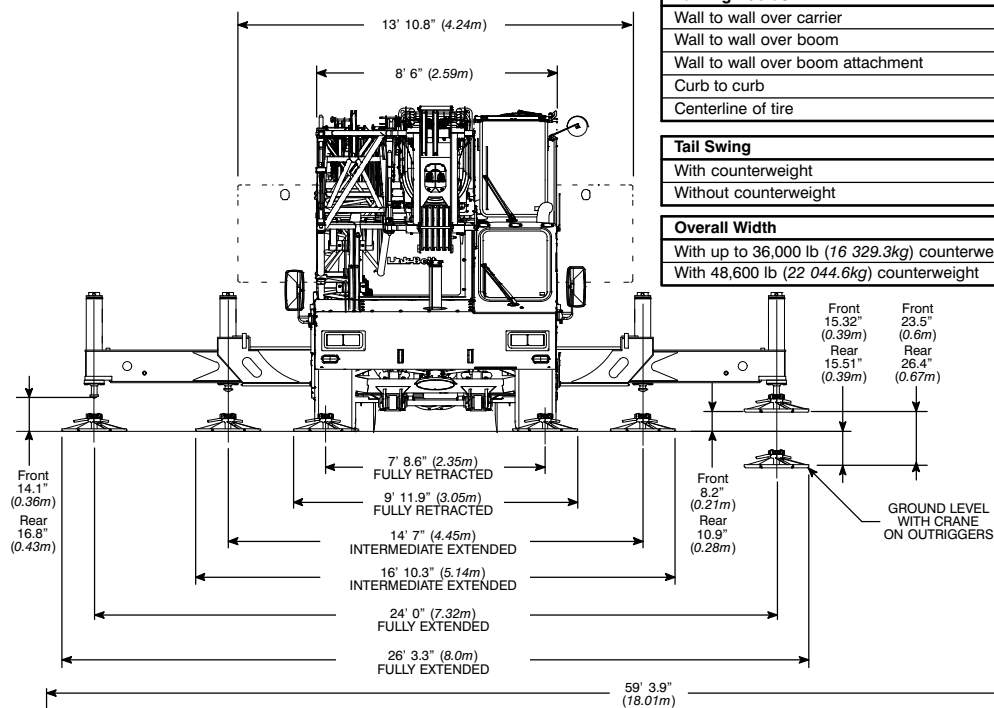

Not To Scale



Working Range Diagram Main Boom + 10' (3.0m) Fly

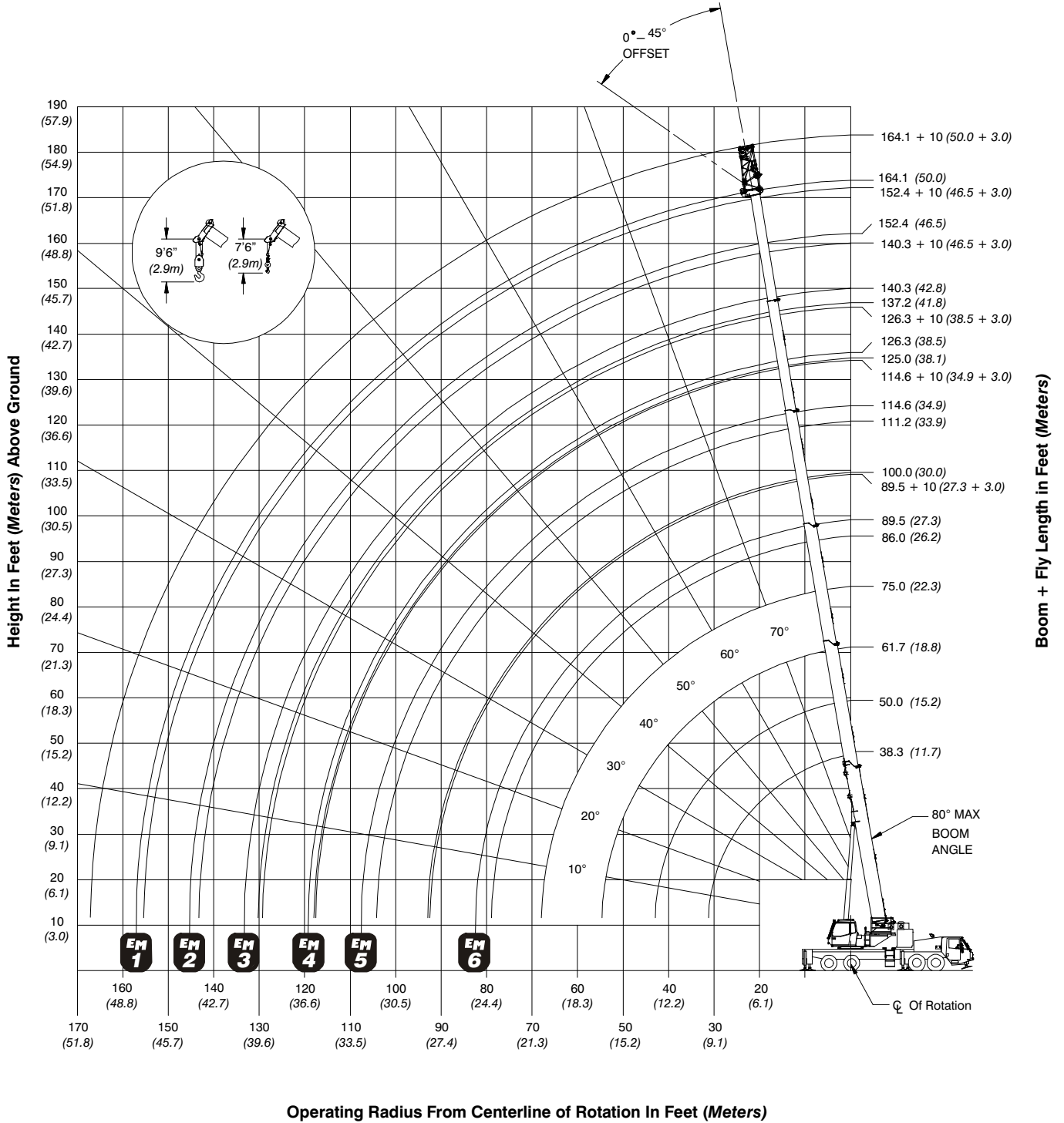



Working Range Diagram Main Boom + Attachments

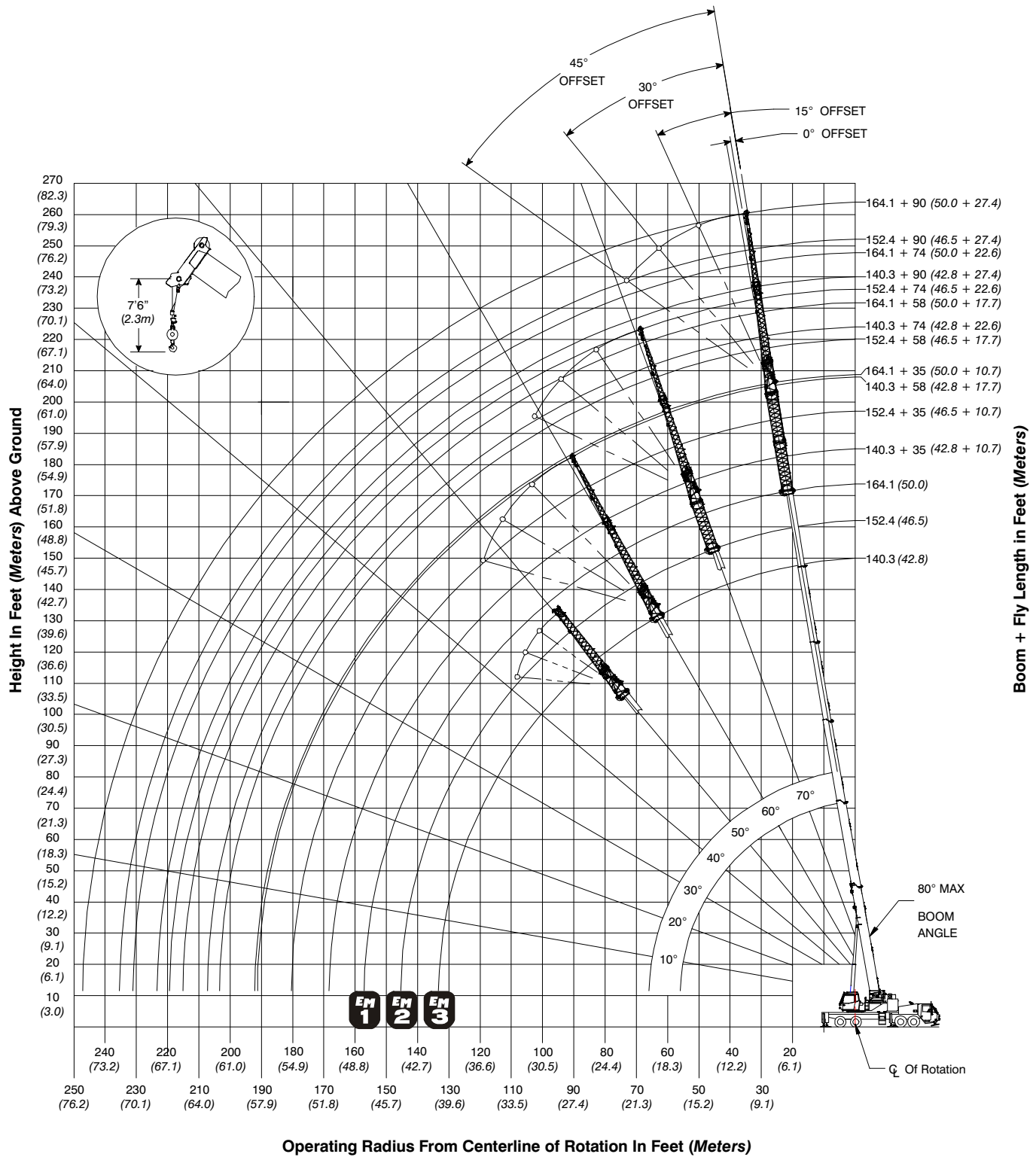



Boom Extend Modes

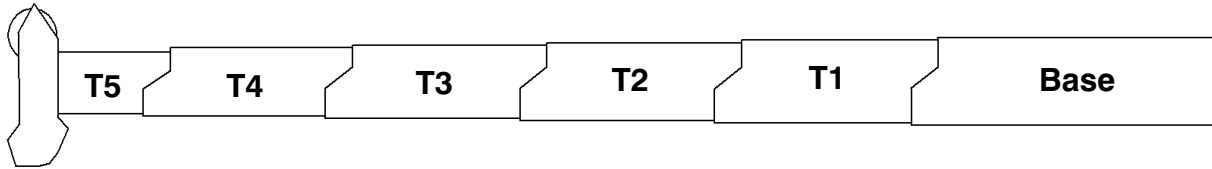

EM 1							
	Boom Length (ft)	Boom Length (m)	Section Length				
			T5	T4	T3	T2	T1
*	38.3	11.68					
	50	15.24	50%				
*	61.7	18.81	100%				
	75	22.87	100%	55%			
*	86	26.22	100%	100%			
	100	30.49	100%	100%	56%		
*	111.2	33.90	100%	100%	100%		
	125	38.11	100%	100%	100%	53%	
*	137.2	41.83	100%	100%	100%	100%	
	150	45.73	100%	100%	100%	100%	48%
*	164.1	50.03	100%	100%	100%	100%	100%

EM 2							
	Boom Length (ft)	Boom Length (m)	Section Length				
			T5	T4	T3	T2	T1
*	38.3	11.68					
*	50	15.24	50%				
	60	18.29	50%	41%			
*	74.3	22.65	50%	100%			
	85	25.97	50%	100%	43%		
*	99.5	30.34	50%	100%	100%		
	110	33.54	50%	100%	100%	40%	
*	125.5	38.26	50%	100%	100%	100%	
	140	42.68	50%	100%	100%	100%	54%
*	152.4	46.46	50%	100%	100%	100%	100%

EM 3							
	Boom Length (ft)	Boom Length (m)	Section Length				
			T5	T4	T3	T2	T1
*	38.3	11.68					
*	50	15.24	50%				
*	62.1	18.93	50%	50%			
	75	22.87	50%	50%	51%		
*	87.3	26.62	50%	50%	100%		
	100	30.49	50%	50%	100%	49%	
*	113.4	34.57	50%	50%	100%	100%	
	125	38.11	50%	50%	100%	100%	43%
*	140.3	42.77	50%	50%	100%	100%	100%

EM 4							
	Boom Length (ft)	Boom Length (m)	Section Length				
			T5	T4	T3	T2	T1
	38.3	11.68					
	50	15.24	50%				
	61.7	18.81	100%				
	73.8	22.50	100%	50%			
	86.4	26.34	100%	50%	50%		
	99.4	30.30	100%	50%	50%	50%	
	115	35.06	100%	50%	50%	50%	
	126.3	38.51	100%	50%	50%	50%	

EM 5						
Boom Length (ft)	Boom Length (m)	Section Length				
		T5	T4	T3	T2	T1
38.3	11.68					
50	15.24	50%				
62.1	18.93	50%	50%			
74.7	22.77	50%	50%	50%		
87.8	26.77	50%	50%	50%	50%	
100	30.49	50%	50%	50%	50%	46%
114.6	34.94	50%	50%	50%	50%	100%

EM 6						
Boom Length (ft)	Boom Length (m)	Section Length				
		T5	T4	T3	T2	T1
38.3	11.68					
50.5	15.40	0%	50%			
63	19.20	0%	50%	50%		
76.1	23.20	0%	50%	50%	50%	
89.5	27.29	0%	50%	50%	50%	50%

* Denotes boom lengths charted with 35 ft (10.7m), 58 ft (17.7m), 74 ft (22.6m), and 90 ft (27.4m) fly.



Main Boom Lift Capacity Charts – Imperial B30.5 – Standard

8,000 lb Counterweight – Fully Extended Outriggers – 360° Rotation (All Capacities Are Listed In Pounds)												
Radius (ft)	Main Boom											Radius (ft)
	Boom Length (ft)											
	38.3	50.0- 50.5	60.0- 63.0	73.8- 76.1	85.0- 89.5	99.4- 100.0	110.0- 115.0	125.0- 126.3	137.2- 140.3	150.0- 152.4	164.1	
10	151,400	152,900	137,600									10
12	134,900	136,600	136,900	120,400								12
15	110,800	113,600	114,400	113,900	91,500							15
20	80,500	83,400	84,400	84,200	83,200	65,800	50,400					20
25	56,000	59,900	62,600	63,200	62,600	61,400	50,400	38,700	25,400			25
30	38,800	43,500	45,200	45,700	45,200	45,500	44,200	38,700	30,800	24,400		30
35		32,800	34,600	35,000	35,400	35,700	35,600	33,700	30,800	24,400	19,600	35
40		25,600	27,500	29,100	29,100	28,800	28,500	29,100	27,200	24,400	19,600	40
45			22,800	23,900	23,900	24,400	24,400	23,900	23,600	22,500	19,600	45
50			18,800	19,900	20,500	20,500	20,500	20,000	19,600	18,900	18,300	50
55			15,200	16,800	17,400	17,300	17,300	16,800	16,500	15,800	15,300	55
60				14,300	14,900	14,900	14,900	14,400	14,100	13,400	12,700	60
65				12,100	12,800	12,800	12,800	12,300	12,000	11,300	10,700	65
70					11,000	11,000	11,000	10,600	10,300	9,600	9,000	70
75					9,500	9,600	9,600	9,200	8,800	8,200	7,600	75
80					7,000	8,300	8,400	7,900	7,600	7,000	6,400	80
85						7,200	7,300	6,900	6,500	5,900	5,300	85
90						6,300	6,300	5,900	5,600	5,000	4,400	90
95								5,500	5,100	4,800	4,200	95
100								4,700	4,400	4,100	3,500	100
105								2,300	3,700	3,400	2,800	105
110									3,100	2,900	2,300	110
115									2,600	2,300	1,700	115
120										1,800	1,300	120
125										1,400		125
130										1,000		130

This information is not for crane operation. Operator must refer to the in-cab information for crane operation. Rated lifting capacities shown on fully extended outriggers do not exceed 85% of the tipping loads and on tires do not exceed 75% of the tipping loads.



16,000 lb Counterweight – Fully Extended Outriggers – 360° Rotation												
(All Capacities Are Listed In Pounds)												
Radius (ft)	Main Boom											Radius (ft)
	Boom Length (ft)											
	38.3	50.0- 50.5	60.0- 63.0	73.8- 76.1	85.0- 89.5	99.4- 100.0	110.0- 115.0	125.0- 126.3	137.2- 140.3	150.0- 152.4	164.1	
10	153,100	154,500	137,600									10
12	136,500	138,100	137,600	120,400								12
15	116,400	118,700	119,200	115,800	91,500							15
20	84,800	87,700	88,600	88,400	87,400	65,800	50,400					20
25	65,200	68,200	69,200	69,100	70,400	65,800	50,400	38,700	25,400			25
30	46,000	50,600	52,300	52,800	52,300	51,200	50,200	38,700	30,800	24,400		30
35		38,500	40,400	40,800	40,300	40,600	40,000	38,700	30,800	24,400	19,600	35
40		30,400	32,300	32,700	32,900	33,300	32,700	32,700	30,800	24,400	19,600	40
45			26,400	27,500	28,000	27,800	27,400	27,900	26,200	24,400	19,600	45
50			22,400	23,600	23,600	23,600	24,100	23,600	23,300	22,500	19,600	50
55			18,400	20,000	20,200	20,700	20,600	20,200	19,800	19,100	18,500	55
60				17,200	17,800	17,900	17,900	17,400	17,100	16,400	15,800	60
65				14,900	15,600	15,700	15,700	15,300	14,900	14,300	13,700	65
70					13,600	13,800	13,800	13,400	13,100	12,400	11,800	70
75					12,000	12,100	12,200	11,800	11,400	10,800	10,200	75
80					9,400	10,700	10,800	10,300	10,000	9,400	8,800	80
85						9,500	9,500	9,100	8,800	8,100	7,600	85
90						8,400	8,400	8,000	7,700	7,100	6,500	90
95							7,500	7,100	6,800	6,200	5,600	95
100							6,600	6,200	5,900	5,300	4,800	100
105							4,100	5,500	5,200	4,600	4,000	105
110								4,800	4,500	3,900	3,400	110
115								4,200	3,900	3,300	2,800	115
120									3,400	2,800	2,200	120
125									2,900	2,300	1,700	125
130									2,400	1,800	1,300	130
135										1,400		135

This information is not for crane operation. Operator must refer to the in-cab information for crane operation. Rated lifting capacities shown on fully extended outriggers do not exceed 85% of the tipping loads and on tires do not exceed 75% of the tipping loads.



Main Boom Lift Capacity Charts – Imperial B30.5 – Optional

24,000 lb Counterweight – Fully Extended Outriggers – 360° Rotation (All Capacities Are Listed In Pounds)												
Radius (ft)	Main Boom											Radius (ft)
	Boom Length (ft)											
	38.3	50.0- 50.5	60.0- 63.0	73.8- 76.1	85.0- 89.5	99.4- 100.0	110.0- 115.0	125.0- 126.3	137.2- 140.3	150.0- 152.4	164.1	
7	180,000											7
8	172,500											8
9	162,900											9
10	154,300	155,500	137,600									10
12	138,000	139,600	137,600	120,400								12
15	118,200	120,000	120,500	115,800	91,500							15
20	89,100	92,000	92,900	92,700	91,500	65,800	50,400					20
25	68,700	71,700	72,700	72,600	71,700	65,800	50,400	38,700	25,400			25
30	53,100	57,000	58,100	59,900	59,400	58,400	50,400	38,700	30,800	24,400		30
35		44,300	46,100	46,500	46,100	45,100	44,200	38,700	30,800	24,400	19,600	35
40		35,200	37,100	37,500	37,100	37,300	36,900	36,300	30,800	24,400	19,600	40
45			30,500	31,100	31,300	31,700	30,600	30,100	29,200	24,400	19,600	45
50			25,600	26,100	27,200	26,800	26,700	26,300	25,500	24,400	19,600	50
55			21,700	23,300	23,400	23,200	22,800	23,400	23,100	22,400	19,600	55
60				20,100	20,300	20,500	20,800	20,300	20,000	19,300	18,700	60
65				17,600	17,700	18,200	18,200	17,800	17,400	16,800	16,200	65
70					15,800	16,100	16,100	15,800	15,500	14,800	14,300	70
75					14,200	14,400	14,400	14,000	13,700	13,100	12,500	75
80					11,500	12,800	12,800	12,500	12,200	11,500	11,000	80
85						11,400	11,500	11,100	10,800	10,200	9,600	85
90						10,200	10,300	9,900	9,700	9,100	8,500	90
95							9,200	8,900	8,600	8,000	7,500	95
100							8,300	8,000	7,700	7,100	6,600	100
105							5,800	7,100	6,900	6,300	5,800	105
110								6,400	6,100	5,600	5,000	110
115								5,700	5,400	4,900	4,400	115
120									4,800	4,300	3,700	120
125									4,300	3,700	3,200	125
130									3,800	3,200	2,700	130
135										2,700	2,200	135
140										2,300	1,800	140
145											1,400	145
150											1,000	150

This information is not for crane operation. Operator must refer to the in-cab information for crane operation. Rated lifting capacities shown on fully extended outriggers do not exceed 85% of the tipping loads and on tires do not exceed 75% of the tipping loads.



36,000 lb Counterweight – Fully Extended Outriggers – 360° Rotation												
(All Capacities Are Listed In Pounds)												
Radius (ft)	Main Boom											Radius (ft)
	Boom Length (ft)											
	38.3	50.0- 50.5	60.0- 63.0	73.8- 76.1	85.0- 89.5	99.4- 100.0	110.0- 115.0	125.0- 126.3	137.2- 140.3	150.0- 152.4	164.1	
7	180,000											7
8	173,500											8
9	163,900											9
10	155,200	156,400	137,600									10
12	140,100	141,500	137,600	120,400								12
15	120,200	122,000	120,800	115,800	91,500							15
20	95,500	98,100	98,800	96,100	91,500	65,800	50,400					20
25	73,900	76,900	77,900	77,700	76,900	65,800	50,400	38,700	25,400			25
30	59,300	62,300	63,300	63,300	64,400	63,600	50,400	38,700	30,800	24,400		30
35		51,700	52,800	54,300	54,000	53,300	46,200	38,700	30,800	24,400	19,600	35
40		42,400	44,300	44,700	44,300	43,400	41,700	38,200	30,800	24,400	19,600	40
45			36,700	37,200	36,800	35,900	35,100	35,300	30,800	24,400	19,600	45
50			31,000	31,600	31,200	31,500	31,100	30,500	29,500	24,400	19,600	50
55			25,400	27,100	27,400	27,800	26,800	26,100	26,500	24,400	19,600	55
60				23,500	24,600	24,200	24,100	23,700	23,000	22,500	19,600	60
65				20,800	21,700	21,300	21,200	21,200	21,400	20,800	19,600	65
70					19,200	19,100	18,800	19,300	19,000	18,300	17,700	70
75					17,100	17,000	16,900	17,200	16,900	16,300	15,700	75
80					14,600	15,800	15,900	15,600	15,300	14,700	14,100	80
85						14,300	14,400	14,000	13,800	13,100	12,600	85
90						13,000	13,000	12,700	12,400	11,800	11,200	90
95							11,800	11,500	11,200	10,600	10,100	95
100							10,700	10,400	10,100	9,600	9,000	100
105							8,100	9,400	9,200	8,600	8,100	105
110								8,600	8,300	7,800	7,200	110
115								7,800	7,500	7,000	6,500	115
120									6,800	6,300	5,800	120
125									6,200	5,600	5,100	125
130									5,100	5,000	4,500	130
135										4,500	4,000	135
140										4,000	3,500	140
145											3,000	145
150											2,600	150

This information is not for crane operation. Operator must refer to the in-cab information for crane operation. Rated lifting capacities shown on fully extended outriggers do not exceed 85% of the tipping loads and on tires do not exceed 75% of the tipping loads.



48,600 lb Counterweight – Fully Extended Outriggers – 360° Rotation (All Capacities Are Listed In Pounds)												
Radius (ft)	Main Boom											Radius (ft)
	Boom Length (ft)											
	38.3	50.0- 50.5	60.0- 63.0	73.8- 76.1	85.0- 89.5	99.4- 100.0	110.0- 115.0	125.0- 126.3	137.2- 140.3	150.0- 152.4	164.1	
7	180,000											7
8	174,400											8
9	164,800											9
10	156,200	157,200	137,600									10
12	141,000	142,400	137,600	120,400								12
15	122,300	124,100	120,800	115,800	91,500							15
20	97,800	99,900	100,400	96,100	91,500	65,800	50,400					20
25	79,400	82,200	83,200	82,200	78,200	65,800	50,400	38,700	25,400			25
30	60,700	66,800	67,800	67,700	66,900	65,800	50,400	38,700	30,800	24,400		30
35		55,700	56,700	57,200	57,900	57,200	46,200	38,700	30,800	24,400	19,600	35
40		47,200	48,500	49,800	49,500	48,700	41,700	38,200	30,800	24,400	19,600	40
45			42,800	43,300	43,000	42,300	37,800	35,300	30,800	24,400	19,600	45
50			36,700	37,200	36,800	36,000	34,500	33,000	29,500	24,400	19,600	50
55			28,500	32,100	31,800	31,100	30,700	30,600	27,400	24,400	19,600	55
60				28,100	27,800	28,100	27,800	27,200	25,600	23,700	19,600	60
65				24,700	24,500	25,500	24,400	23,900	24,000	22,500	19,600	65
70					22,200	22,700	21,700	21,100	21,500	21,400	19,600	70
75					20,600	20,300	20,000	19,500	19,200	19,800	18,900	75
80					15,700	18,200	18,200	17,900	17,600	17,800	17,200	80
85						16,500	16,400	16,600	16,500	16,100	15,600	85
90						15,200	14,900	15,500	15,300	14,700	14,100	90
95							13,600	14,200	13,900	13,300	12,800	95
100							12,700	12,900	12,700	12,100	11,600	100
105							10,500	11,800	11,600	11,000	10,500	105
110								10,900	10,600	10,100	9,500	110
115								10,000	9,700	9,200	8,600	115
120									8,900	8,400	7,800	120
125									8,200	7,600	7,100	125
130									6,300	6,900	6,400	130
135										6,300	5,800	135
140										5,800	5,200	140
145											4,700	145
150											4,200	150

This information is not for crane operation. Operator must refer to the in-cab information for crane operation. Rated lifting capacities shown on fully extended outriggers do not exceed 85% of the tipping loads and on tires do not exceed 75% of the tipping loads.



Manual Offset Fly Lift Capacity Charts – Imperial B30.5 – Optional

8,000 lb Counterweight – Fully Extended Outriggers – 360° Rotation (All Capacities Are Listed In Pounds)												
Radius (ft)	Main Boom +10 ft Manual Offset Fly (0°, 15°, 30°, 45° Offsets)											Radius (ft)
	Boom Length (ft)											
	38.3	50.0- 50.5	60.0- 63.0	73.8- 76.1	85.0- 89.5	99.4- 100.0	110.0- 115.0	125.0- 126.3	137.2- 140.3	150.0- 152.4	164.1	
10	42,100	42,900	47,700									10
12	41,100	42,100	44,900	47,600								12
15	39,400	40,900	41,700	42,300	47,200							15
20	36,400	38,600	40,200	40,900	41,300	41,100	39,500					20
25	34,400	36,300	38,000	39,200	40,100	39,900	39,500	30,400	20,500			25
30	33,400	34,400	36,200	37,500	38,500	38,600	38,600	30,400	25,400	18,500		30
35	32,100	33,600	33,900	34,200	34,900	34,500	34,000	30,400	25,400	20,400	15,900	35
40	25,200	26,800	28,000	28,000	28,100	27,600	28,000	26,600	25,400	20,400	15,900	40
45		22,100	22,900	22,900	23,400	23,300	22,900	23,300	21,500	20,400	15,900	45
50		18,300	19,000	19,500	19,800	20,100	20,000	19,400	19,000	18,300	15,900	50
55			16,300	16,900	17,200	17,000	16,900	16,300	15,900	15,300	14,600	55
60			13,900	14,400	14,700	14,500	14,400	13,900	13,500	12,800	12,100	60
65			11,400	12,300	12,600	12,500	12,400	11,800	11,400	10,700	10,100	65
70				10,600	10,900	10,700	10,600	10,100	9,700	9,000	8,400	70
75				9,200	9,400	9,300	9,200	8,700	8,300	7,600	7,000	75
80					8,200	8,000	7,900	7,400	7,100	6,400	5,800	80
85					7,100	7,000	6,900	6,400	6,000	5,300	4,700	85
90					5,100	6,100	5,900	5,500	5,100	4,400	3,800	90
95						5,200	5,100	4,600	4,300	3,600	3,000	95
100						4,500	4,400	3,900	3,600	2,900	2,300	100
105							3,800	3,300	2,900	2,300	1,700	105
110							3,200	2,700	2,400	1,700	1,100	110
115							1,100	2,200	1,800	1,200		115
120								1,800	1,400			120
125								1,300	1,000			125

This information is not for crane operation. Operator must refer to the in-cab information for crane operation. Rated lifting capacities shown on fully extended outriggers do not exceed 85% of the tipping loads and on tires do not exceed 75% of the tipping loads.



16,000 lb Counterweight – Fully Extended Outriggers – 360° Rotation (All Capacities Are Listed In Pounds)												
Radius (ft)	Main Boom +10 ft Manual Offset Fly (0°, 15°, 30°, 45° Offsets)											Radius (ft)
	Boom Length (ft)											
	38.3	50.0- 50.5	60.0- 63.0	73.8- 76.1	85.0- 89.5	99.4- 100.0	110.0- 115.0	125.0- 126.3	137.2- 140.3	150.0- 152.4	164.1	
10	42,100	42,900	47,700									10
12	41,100	42,100	44,900	47,600								12
15	39,400	40,900	41,700	42,300	47,200							15
20	36,400	38,600	40,200	40,900	41,300	41,100	39,500					20
25	34,400	36,300	38,000	39,200	40,100	39,900	39,500	30,400	20,500			25
30	33,400	34,400	36,200	37,500	38,500	38,600	38,600	30,400	25,400	18,500		30
35	32,500	34,000	34,600	36,000	37,100	37,300	37,500	30,400	25,400	20,400	15,900	35
40	30,000	31,400	31,700	32,000	32,100	32,200	31,700	30,400	25,400	20,400	15,900	40
45		25,700	27,000	27,000	27,000	26,500	26,400	26,500	24,500	20,400	15,900	45
50		21,900	22,600	22,600	22,700	23,000	22,600	22,100	21,300	20,400	15,900	50
55			19,200	19,500	19,700	19,600	19,600	19,600	19,200	18,500	15,900	55
60			16,500	17,100	17,200	17,400	17,400	16,900	16,500	15,800	15,300	60
65			14,400	15,200	15,000	15,300	15,200	14,700	14,400	13,700	13,100	65
70				13,300	13,600	13,400	13,300	12,900	12,500	11,800	11,200	70
75				11,700	12,000	11,800	11,700	11,300	10,900	10,200	9,600	75
80					10,600	10,400	10,300	9,800	9,500	8,800	8,200	80
85					9,400	9,200	9,100	8,600	8,300	7,600	7,000	85
90					7,200	8,200	8,000	7,600	7,200	6,500	5,900	90
95						7,200	7,100	6,600	6,300	5,600	5,000	95
100						6,400	6,300	5,800	5,400	4,800	4,200	100
105							5,500	5,100	4,700	4,000	3,400	105
110							4,900	4,400	4,000	3,400	2,800	110
115							2,700	3,800	3,400	2,800	2,200	115
120								3,300	2,900	2,300	1,700	120
125								2,800	2,400	1,800	1,200	125
130									2,000	1,300		130
135									1,600	900		135
140									1,200			140

This information is not for crane operation. Operator must refer to the in-cab information for crane operation. Rated lifting capacities shown on fully extended outriggers do not exceed 85% of the tipping loads and on tires do not exceed 75% of the tipping loads.



24,000 lb Counterweight – Fully Extended Outriggers – 360° Rotation												
(All Capacities Are Listed In Pounds)												
Radius (ft)	Main Boom +10 ft Manual Offset Fly (0°, 15°, 30°, 45° Offsets)											Radius (ft)
	Boom Length (ft)											
	38.3	50.0- 50.5	60.0- 63.0	73.8- 76.1	85.0- 89.5	99.4- 100.0	110.0- 115.0	125.0- 126.3	137.2- 140.3	150.0- 152.4	164.1	
10	42,100	42,900	47,700									10
12	41,100	42,100	44,900	47,600								12
15	39,400	40,900	41,700	42,300	47,200							15
20	36,400	38,600	40,200	40,900	41,300	41,100	39,500					20
25	34,400	36,300	38,000	39,200	40,100	39,900	39,500	30,400	20,500			25
30	33,400	34,400	36,200	37,500	38,500	38,600	38,600	30,400	25,400	18,500		30
35	32,500	34,000	34,600	36,000	37,100	37,300	37,500	30,400	25,400	20,400	15,900	35
40	32,500	32,900	34,400	34,800	34,800	35,200	34,900	30,400	25,400	20,400	15,900	40
45		29,800	30,100	30,000	30,600	30,700	30,200	29,500	25,400	20,400	15,900	45
50		25,000	26,200	26,300	26,300	25,800	25,300	25,300	23,900	20,400	15,900	50
55			22,500	22,400	22,400	22,000	22,400	21,900	21,100	20,400	15,900	55
60			19,400	19,400	19,700	19,800	19,400	19,400	19,400	18,500	15,900	60
65			17,000	16,900	17,300	17,200	17,200	17,200	16,900	16,200	15,700	65
70				15,400	15,600	15,400	15,800	15,300	14,900	14,200	13,600	70
75				14,000	13,800	14,100	14,000	13,500	13,100	12,500	11,900	75
80					12,300	12,500	12,500	12,000	11,600	11,000	10,300	80
85					11,400	11,200	11,100	10,600	10,300	9,600	9,000	85
90					9,200	10,100	10,000	9,500	9,100	8,500	7,900	90
95						9,000	8,900	8,500	8,100	7,500	6,900	95
100						8,200	8,000	7,600	7,200	6,600	6,000	100
105							7,200	6,700	6,400	5,800	5,200	105
110							6,500	6,000	5,700	5,000	4,500	110
115							4,300	5,400	5,000	4,400	3,800	115
120								4,800	4,400	3,800	3,200	120
125								4,200	3,900	3,200	2,600	125
130									3,400	2,700	2,100	130
135									2,900	2,300	1,700	135
140									2,500	1,800	1,200	140
145										1,500		145

This information is not for crane operation. Operator must refer to the in-cab information for crane operation. Rated lifting capacities shown on fully extended outriggers do not exceed 85% of the tipping loads and on tires do not exceed 75% of the tipping loads.



36,000 lb Counterweight – Fully Extended Outriggers – 360° Rotation												
(All Capacities Are Listed In Pounds)												
Radius (ft)	Main Boom +10 ft Manual Offset Fly (0°, 15°, 30°, 45° Offsets)											Radius (ft)
	Boom Length (ft)											
	38.3	50.0- 50.5	60.0- 63.0	73.8- 76.1	85.0- 89.5	99.4- 100.0	110.0- 115.0	125.0- 126.3	137.2- 140.3	150.0- 152.4	164.1	
10	42,100	42,900	47,700									10
12	41,100	42,100	44,900	47,600								12
15	39,400	40,900	41,700	42,300	47,200							15
20	36,400	38,600	40,200	40,900	41,300	41,100	39,500					20
25	34,400	36,300	38,000	39,200	40,100	39,900	39,500	30,400	20,500			25
30	33,400	34,400	36,200	37,500	38,500	38,600	38,600	30,400	25,400	18,500		30
35	32,500	34,000	34,600	36,000	37,100	37,300	37,500	30,400	25,400	20,400	15,900	35
40	32,500	32,900	34,400	34,800	35,900	35,200	36,300	30,400	25,400	20,400	15,900	40
45		32,400	33,400	34,400	34,600	33,500	34,500	30,400	25,400	20,400	15,900	45
50		30,400	30,700	30,200	30,300	30,200	29,300	29,700	25,400	20,400	15,900	50
55			26,300	27,000	26,700	26,800	26,100	25,700	24,900	20,400	15,900	55
60			23,800	23,800	23,200	23,300	22,900	22,300	22,400	20,400	15,900	60
65			20,000	20,900	20,900	20,400	20,200	20,300	19,500	19,000	15,900	65
70				18,500	18,400	18,000	18,400	17,900	18,000	17,700	15,900	70
75				16,500	16,400	16,500	16,300	16,300	16,400	15,700	15,200	75
80					15,200	15,100	14,700	15,100	14,700	14,100	13,500	80
85					13,900	13,500	13,600	13,600	13,200	12,600	12,000	85
90					11,400	12,300	12,700	12,200	11,900	11,200	10,600	90
95						11,600	11,500	11,000	10,700	10,000	9,500	95
100						10,600	10,500	10,000	9,600	9,000	8,400	100
105							9,500	9,000	8,700	8,100	7,500	105
110							8,700	8,200	7,900	7,200	6,600	110
115							6,400	7,400	7,100	6,500	5,900	115
120								6,800	6,400	5,800	5,200	120
125								6,200	5,800	5,200	4,600	125
130									5,200	4,600	4,000	130
135									4,700	4,100	3,500	135
140									3,400	3,600	3,000	140
145										3,100	2,500	145
150											2,100	150
155											1,700	155
160											1,300	160

This information is not for crane operation. Operator must refer to the in-cab information for crane operation. Rated lifting capacities shown on fully extended outriggers do not exceed 85% of the tipping loads and on tires do not exceed 75% of the tipping loads.



48,600 lb Counterweight – Fully Extended Outriggers – 360° Rotation												
(All Capacities Are Listed In Pounds)												
Radius (ft)	Main Boom +10 ft Manual Offset Fly (0°, 15°, 30°, 45° Offsets)											Radius (ft)
	Boom Length (ft)											
	38.3	50.0- 50.5	60.0- 63.0	73.8- 76.1	85.0- 89.5	99.4- 100.0	110.0- 115.0	125.0- 126.3	137.2- 140.3	150.0- 152.4	164.1	
10	42,100	42,900	47,700									10
12	41,100	42,100	44,900	47,600								12
15	39,400	40,900	41,700	42,300	47,200							15
20	36,400	38,600	40,200	40,900	41,300	41,100	39,500					20
25	34,400	36,300	38,000	39,200	40,100	39,900	39,500	30,400	20,500			25
30	33,400	34,400	36,200	37,500	38,500	38,600	38,600	30,400	25,400	18,500		30
35	32,500	34,000	34,600	36,000	37,100	37,300	37,500	30,400	25,400	20,400	15,900	35
40	32,500	32,900	34,400	34,800	35,900	35,200	36,300	30,400	25,400	20,400	15,900	40
45		32,400	33,400	34,400	34,800	33,500	34,500	30,400	25,400	20,400	15,900	45
50		32,400	32,700	33,800	34,400	31,900	33,000	29,700	25,400	20,400	15,900	50
55			31,400	30,900	29,900	30,400	30,000	27,600	25,400	20,400	15,900	55
60			27,400	26,900	27,600	26,900	26,000	25,700	23,900	20,400	15,900	60
65			21,700	24,800	24,500	23,600	22,700	23,500	22,200	20,400	15,900	65
70				22,300	21,700	21,800	21,000	20,700	20,800	19,500	15,900	70
75				20,000	19,400	19,500	19,100	18,400	18,600	18,100	15,900	75
80					17,400	17,500	17,100	16,900	16,600	16,600	15,900	80
85					16,200	15,800	15,800	15,800	15,300	15,600	15,000	85
90					12,500	14,900	14,700	14,300	14,400	14,100	13,500	90
95						13,500	13,400	13,400	13,400	12,800	12,200	95
100						12,400	12,200	12,500	12,200	11,600	11,000	100
105							11,100	11,500	11,100	10,500	9,900	105
110							10,300	10,500	10,200	9,500	8,900	110
115							8,500	9,600	9,300	8,700	8,100	115
120								8,900	8,500	7,900	7,300	120
125								8,200	7,800	7,200	6,600	125
130									7,100	6,500	5,900	130
135									6,500	5,900	5,300	135
140									3,400	5,300	4,800	140
145										4,800	4,200	145
150											3,800	150
155											3,300	155
160											2,900	160

This information is not for crane operation. Operator must refer to the in-cab information for crane operation. Rated lifting capacities shown on fully extended outriggers do not exceed 85% of the tipping loads and on tires do not exceed 75% of the tipping loads.



8,000 lb Counterweight – Fully Extended Outriggers – 360° Rotation (All Capacities Are Listed In Pounds)									
164.1 ft Main Boom Length									
Radius (ft)	35 ft Manual Offset Fly				58 ft Manual Offset Fly				Radius (ft)
	0°	15°	30°	45°	0°	15°	30°	45°	
40	11,100								40
45	11,100								45
50	11,100								50
55	11,100	11,600			7,500				55
60	11,100	11,600			7,500				60
65	10,800	11,600	11,300		7,500	7,800			65
70	9,000	10,200	11,100	10,100	7,500	7,600			70
75	7,600	8,600	9,500	9,900	7,500	7,500			75
80	6,400	7,300	8,100	8,700	7,000	7,300	6,300		80
85	5,300	6,200	6,900	7,500	5,900	7,200	6,100		85
90	4,400	5,200	5,800	6,300	5,000	6,300	6,000	5,300	90
95	3,600	4,300	4,900	5,400	4,200	5,300	5,900	5,200	95
100	2,800	3,500	4,100	4,500	3,400	4,500	5,500	5,200	100
105	2,200	2,800	3,300	3,700	2,800	3,800	4,700	5,100	105
110	1,600	2,200	2,700	3,000	2,200	3,100	4,000	4,600	110
115	1,100	1,600	2,100	2,400	1,700	2,500	3,300	3,900	115
120		1,100	1,500	1,800	1,200	2,000	2,700	3,300	120
125			1,000	1,300		1,500	2,200	2,700	125
130						1,100	1,700	2,100	130
135							1,200	1,600	135
140								1,200	140

This information is not for crane operation. Operator must refer to the in-cab information for crane operation. Rated lifting capacities shown on fully extended outriggers do not exceed 85% of the tipping loads and on tires do not exceed 75% of the tipping loads.



16,000 lb Counterweight – Fully Extended Outriggers – 360° Rotation (All Capacities Are Listed In Pounds)									
164.1 ft Main Boom Length									
Radius (ft)	35 ft Manual Offset Fly				58 ft Manual Offset Fly				Radius (ft)
	0°	15°	30°	45°	0°	15°	30°	45°	
40	11,100								40
45	11,100								45
50	11,100				7,500				50
55	11,100	11,600			7,500				55
60	11,100	11,600			7,500				60
65	11,100	11,600	11,300		7,500	7,800			65
70	11,100	11,600	11,100	10,100	7,500	7,600			70
75	10,200	11,200	11,000	9,900	7,500	7,500			75
80	8,800	9,700	10,500	9,800	7,500	7,300	6,300		80
85	7,600	8,400	9,100	9,600	7,500	7,200	6,100		85
90	6,500	7,300	7,900	8,400	7,100	7,000	6,000	5,300	90
95	5,500	6,300	6,900	7,300	6,100	6,900	5,900	5,200	95
100	4,700	5,400	5,900	6,300	5,300	6,400	5,800	5,200	100
105	4,000	4,600	5,100	5,500	4,500	5,600	5,700	5,100	105
110	3,300	3,900	4,300	4,700	3,900	4,800	5,600	5,100	110
115	2,700	3,200	3,700	4,000	3,200	4,100	4,900	5,000	115
120	2,200	2,600	3,000	3,300	2,700	3,500	4,200	4,800	120
125	1,700	2,100	2,500	2,700	2,200	3,000	3,600	4,100	125
130	1,200	1,600	2,000	2,200	1,700	2,500	3,100	3,500	130
135		1,200	1,500	1,600	1,300	2,000	2,600	3,000	135
140			1,000	1,200	900	1,600	2,100	2,400	140
145						1,200	1,600	2,000	145
150							1,200	1,500	150
155								1,100	155

16,000 lb Counterweight – Fully Extended Outriggers – 360° Rotation (All Capacities Are Listed In Pounds)									
164.1 ft Main Boom Length									
Radius (ft)	74 ft Manual Offset Fly				90 ft Manual Offset Fly				Radius (ft)
	0°	15°	30°	45°	0°	15°	30°	45°	
50	5,300								50
55	5,300								55
60	5,300				4,000				60
65	5,300				4,000				65
70	5,300	5,300			4,000				70
75	5,300	5,200			4,000				75
80	5,300	5,100			4,000	4,100			80
85	5,300	5,000	4,400		4,000	4,000			85
90	5,300	4,800	4,300	3,900	4,000	3,900			90
95	5,300	4,700	4,200	3,800	4,000	3,800	3,500		95
100	5,200	4,600	4,100	3,800	4,000	3,700	3,400	3,200	100
105	4,400	4,500	4,000	3,700	4,000	3,600	3,300	3,100	105
110	3,800	4,400	3,900	3,600	3,800	3,500	3,200	3,000	110
115	3,100	4,100	3,800	3,500	3,200	3,400	3,100	2,900	115
120	2,600	3,500	3,700	3,500	2,600	3,300	3,000	2,800	120
125	2,100	2,900	3,600	3,400	2,100	2,900	2,900	2,700	125
130	1,600	2,400	3,100	3,300	1,600	2,400	2,800	2,700	130
135	1,200	1,900	2,500	3,000	1,200	2,000	2,600	2,600	135
140		1,500	2,100	2,500		1,500	2,100	2,500	140
145		1,100	1,600	2,000		1,100	1,700	2,100	145
150			1,200	1,500			1,300	1,600	150
155				1,100			900	1,200	155

This information is not for crane operation. Operator must refer to the in-cab information for crane operation. Rated lifting capacities shown on fully extended outriggers do not exceed 85% of the tipping loads and on tires do not exceed 75% of the tipping loads.



24,000 lb Counterweight – Fully Extended Outriggers – 360° Rotation (All Capacities Are Listed In Pounds)									
164.1 ft Main Boom Length									
Radius (ft)	35 ft Manual Offset Fly				58 ft Manual Offset Fly				Radius (ft)
	0°	15°	30°	45°	0°	15°	30°	45°	
40	11,100				7,500				40
45	11,100				7,500				45
50	11,100				7,500				50
55	11,100	11,600			7,500	7,800			55
60	11,100	11,600			7,500	7,600			60
65	11,100	11,600	11,300		7,500	7,500			65
70	11,100	11,600	11,100	10,100	7,500	7,300	6,300		70
75	11,100	11,600	11,000	9,900	7,500	7,200	6,100		75
80	10,900	11,600	10,800	9,800	7,500	7,000	6,000	5,300	80
85	9,600	10,400	10,700	9,600	7,500	6,900	5,900	5,200	85
90	8,400	9,200	9,800	9,500	7,000	6,700	5,800	5,200	90
95	7,400	8,100	8,700	9,100	6,200	6,600	5,700	5,100	95
100	6,500	7,100	7,700	8,100	5,500	6,400	5,600	5,100	100
105	5,700	6,300	6,800	7,100	4,800	5,700	5,500	5,000	105
110	4,900	5,500	5,900	6,300	4,200	5,000	5,400	5,000	110
115	4,300	4,800	5,200	5,500	3,600	4,400	5,000	4,900	115
120	3,700	4,100	4,500	4,800	3,100	3,800	4,400	4,900	120
125	3,100	3,600	3,900	4,100	2,600	3,300	3,900	4,300	125
130	2,600	3,000	3,300	3,500	2,200	2,800	3,300	3,700	130
135	2,100	2,500	2,800	3,000	1,800	2,400	2,900	3,200	135
140	1,700	2,000	2,300	2,500	1,400	2,000	2,400	2,700	140
145	1,300	1,600	1,900	2,000	1,100	1,600	2,000	2,200	145
150	900	1,200	1,400	1,500		1,200	1,600	1,800	150
155			1,000			900	1,200	1,400	155
160							900	1,000	160

This information is not for crane operation. Operator must refer to the in-cab information for crane operation. Rated lifting capacities shown on fully extended outriggers do not exceed 85% of the tipping loads and on tires do not exceed 75% of the tipping loads.



24,000 lb Counterweight – Fully Extended Outriggers – 360° Rotation (All Capacities Are Listed In Pounds)									
164.1 ft Main Boom Length									
Radius (ft)	74 ft Manual Offset Fly				90 ft Manual Offset Fly				Radius (ft)
	0°	15°	30°	45°	0°	15°	30°	45°	
50	5,300								50
55	5,300								55
60	5,300				4,000				60
65	5,300				4,000				65
70	5,300	5,300			4,000				70
75	5,300	5,200			4,000				75
80	5,300	5,100			4,000	4,100			80
85	5,300	5,000	4,400		4,000	4,000			85
90	5,300	4,800	4,300	3,900	4,000	3,900			90
95	5,300	4,700	4,200	3,800	4,000	3,800	3,500		95
100	5,300	4,600	4,100	3,800	4,000	3,700	3,400	3,200	100
105	5,200	4,500	4,000	3,700	4,000	3,600	3,300	3,100	105
110	5,100	4,400	3,900	3,600	3,900	3,500	3,200	3,000	110
115	4,700	4,200	3,800	3,500	3,800	3,400	3,100	2,900	115
120	4,100	4,100	3,700	3,500	3,700	3,300	3,000	2,800	120
125	3,500	4,000	3,600	3,400	3,500	3,200	2,900	2,700	125
130	3,000	3,700	3,600	3,300	3,000	3,100	2,800	2,700	130
135	2,500	3,200	3,500	3,300	2,500	3,000	2,700	2,600	135
140	2,100	2,700	3,300	3,200	2,100	2,800	2,700	2,500	140
145	1,700	2,300	2,800	3,200	1,700	2,300	2,600	2,500	145
150	1,300	1,900	2,400	2,700	1,300	1,900	2,400	2,400	150
155	900	1,500	2,000	2,300	900	1,500	2,000	2,300	155
160		1,100	1,600	1,800		1,200	1,600	1,900	160
165			1,200	1,400			1,200	1,500	165
170				1,000			900	1,100	170

This information is not for crane operation. Operator must refer to the in-cab information for crane operation. Rated lifting capacities shown on fully extended outriggers do not exceed 85% of the tipping loads and on tires do not exceed 75% of the tipping loads.



36,000 lb Counterweight – Fully Extended Outriggers – 360° Rotation (All Capacities Are Listed In Pounds)									
164.1 ft Main Boom Length									
Radius (ft)	35 ft Manual Offset Fly				58 ft Manual Offset Fly				Radius (ft)
	0°	15°	30°	45°	0°	15°	30°	45°	
40	11,100								40
45	11,100								45
50	11,100								50
55	11,100	11,600			7,500				55
60	11,100	11,600			7,500				60
65	11,100	11,600	11,300		7,500	7,800			65
70	11,100	11,600	11,100	10,100	7,500	7,600			70
75	11,100	11,600	11,000	9,900	7,500	7,500			75
80	11,100	11,600	10,800	9,800	7,500	7,300	6,300		80
85	11,100	11,600	10,700	9,600	7,500	7,200	6,100		85
90	11,100	11,600	10,500	9,500	7,500	7,000	6,000	5,300	90
95	10,000	10,700	10,300	9,400	7,500	6,900	5,900	5,200	95
100	8,900	9,600	10,100	9,200	7,500	6,700	5,800	5,200	100
105	8,000	8,600	9,100	9,100	7,500	6,600	5,700	5,100	105
110	7,100	7,700	8,100	8,500	7,500	6,500	5,600	5,100	110
115	6,400	6,900	7,300	7,600	6,900	6,300	5,500	5,000	115
120	5,700	6,100	6,500	6,800	6,200	6,200	5,400	5,000	120
125	5,000	5,500	5,800	6,000	5,500	6,100	5,400	4,900	125
130	4,400	4,800	5,200	5,400	4,900	5,600	5,300	4,900	130
135	3,900	4,300	4,600	4,700	4,400	5,100	5,200	4,800	135
140	3,400	3,800	4,000	4,200	3,900	4,500	5,000	4,800	140
145	3,000	3,300	3,500	3,600	3,400	4,000	4,500	4,700	145
150	2,500	2,800	3,000	3,100	3,000	3,500	4,000	4,300	150
155	2,100	2,400	2,600		2,600	3,100	3,500	3,800	155
160	1,800	2,000	2,200		2,200	2,700	3,100	3,300	160
165	1,400	1,600	1,800		1,900	2,300	2,700	2,800	165
170	1,000	1,200	1,400		1,500	2,000	2,300	2,400	170
175		900	1,000		1,200	1,600	1,900	2,000	175
180					900	1,300	1,500		180
185						900	1,100		185

This information is not for crane operation. Operator must refer to the in-cab information for crane operation. Rated lifting capacities shown on fully extended outriggers do not exceed 85% of the tipping loads and on tires do not exceed 75% of the tipping loads.



36,000 lb Counterweight – Fully Extended Outriggers – 360° Rotation (All Capacities Are Listed In Pounds)									
164.1 ft Main Boom Length									
Radius (ft)	74 ft Manual Offset Fly				90 ft Manual Offset Fly				Radius (ft)
	0°	15°	30°	45°	0°	15°	30°	45°	
50	5,300								50
55	5,300								55
60	5,300				4,000				60
65	5,300				4,000				65
70	5,300	5,300			4,000				70
75	5,300	5,200			4,000				75
80	5,300	5,100			4,000	4,100			80
85	5,300	5,000	4,400		4,000	4,000			85
90	5,300	4,800	4,300	3,900	4,000	3,900			90
95	5,300	4,700	4,200	3,800	4,000	3,800	3,500		95
100	5,300	4,600	4,100	3,800	4,000	3,700	3,400	3,200	100
105	5,200	4,500	4,000	3,700	4,000	3,600	3,300	3,100	105
110	5,100	4,400	3,900	3,600	3,900	3,500	3,200	3,000	110
115	4,900	4,200	3,800	3,500	3,800	3,400	3,100	2,900	115
120	4,800	4,100	3,700	3,500	3,700	3,300	3,000	2,800	120
125	4,700	4,000	3,600	3,400	3,600	3,200	2,900	2,700	125
130	4,500	4,000	3,600	3,300	3,400	3,100	2,800	2,700	130
135	4,300	3,900	3,500	3,300	3,300	3,000	2,700	2,600	135
140	3,800	3,800	3,400	3,200	3,200	2,900	2,700	2,500	140
145	3,300	3,700	3,400	3,200	3,100	2,800	2,600	2,500	145
150	2,900	3,500	3,300	3,100	2,900	2,700	2,500	2,400	150
155	2,500	3,000	3,200	3,100	2,400	2,600	2,400	2,300	155
160	2,100	2,600	3,000	3,100	2,100	2,500	2,400	2,300	160
165	1,700	2,200	2,600	2,800	1,700	2,200	2,300	2,200	165
170	1,400	1,900	2,200	2,400	1,300	1,900	2,200	2,200	170
175	1,000	1,500	1,900	2,000	1,000	1,500	1,900	2,100	175
180		1,100	1,500	1,600		1,200	1,500	1,800	180
185			1,100	1,200			1,200	1,300	185
190							1,000		190

This information is not for crane operation. Operator must refer to the in-cab information for crane operation. Rated lifting capacities shown on fully extended outriggers do not exceed 85% of the tipping loads and on tires do not exceed 75% of the tipping loads.



48,600 lb Counterweight – Fully Extended Outriggers – 360° Rotation (All Capacities Are Listed In Pounds)									
164.1 ft Main Boom Length									
Radius (ft)	35 ft Manual Offset Fly				58 ft Manual Offset Fly				Radius (ft)
	0°	15°	30°	45°	0°	15°	30°	45°	
40	11,100								40
45	11,100								45
50	11,100								50
55	11,100	11,600			7,500				55
60	11,100	11,600			7,500				60
65	11,100	11,600	11,300		7,500	7,800			65
70	11,100	11,600	11,100	10,100	7,500	7,600			70
75	11,100	11,600	11,000	9,900	7,500	7,500			75
80	11,100	11,600	10,800	9,800	7,500	7,300	6,300		80
85	11,100	11,600	10,700	9,600	7,500	7,200	6,100		85
90	11,100	11,600	10,500	9,500	7,500	7,000	6,000	5,300	90
95	11,100	11,500	10,300	9,400	7,500	6,900	5,900	5,200	95
100	11,100	11,400	10,100	9,200	7,500	6,700	5,800	5,200	100
105	10,400	11,000	10,000	9,100	7,500	6,600	5,700	5,100	105
110	9,400	10,000	9,800	9,000	7,500	6,500	5,600	5,100	110
115	8,500	9,100	9,500	9,000	7,500	6,300	5,500	5,000	115
120	7,700	8,200	8,600	8,900	7,300	6,200	5,400	5,000	120
125	7,000	7,500	7,800	8,000	7,200	6,100	5,400	4,900	125
130	6,400	6,800	7,100	7,300	6,900	6,000	5,300	4,900	130
135	5,700	6,100	6,400	6,600	6,200	5,900	5,200	4,800	135
140	5,200	5,500	5,800	5,900	5,700	5,700	5,100	4,800	140
145	4,700	5,000	5,200	5,300	5,100	5,600	5,100	4,700	145
150	4,200	4,500	4,700	4,800	4,700	5,200	5,000	4,700	150
155	3,700	4,000	4,200	4,200	4,200	4,700	4,900	4,700	155
160	3,300	3,500	3,700		3,800	4,200	4,600	4,700	160
165	2,900	3,100	3,300		3,400	3,800	4,100	4,300	165
170	2,500	2,700	2,800		3,000	3,400	3,700	3,800	170
175	2,100	2,300	2,300		2,600	3,000	3,300	3,400	175
180	1,700	1,900			2,200	2,600	2,900	2,900	180
185	1,400	1,500			1,900	2,200	2,500		185
190					1,600	1,900	2,100		190
195					1,300	1,500	1,700		195
200					1,000	1,200	1,300		200
205						900			205

This information is not for crane operation. Operator must refer to the in-cab information for crane operation. Rated lifting capacities shown on fully extended outriggers do not exceed 85% of the tipping loads and on tires do not exceed 75% of the tipping loads.



48,600 lb Counterweight – Fully Extended Outriggers – 360° Rotation (All Capacities Are Listed In Pounds)									
164.1 ft Main Boom Length									
Radius (ft)	74 ft Manual Offset Fly				90 ft Manual Offset Fly				Radius (ft)
	0°	15°	30°	45°	0°	15°	30°	45°	
50	5,300								50
55	5,300								55
60	5,300				4,000				60
65	5,300				4,000				65
70	5,300	5,300			4,000				70
75	5,300	5,200			4,000				75
80	5,300	5,100			4,000	4,100			80
85	5,300	5,000	4,400		4,000	4,000			85
90	5,300	4,800	4,300	3,900	4,000	3,900			90
95	5,300	4,700	4,200	3,800	4,000	3,800	3,500		95
100	5,300	4,600	4,100	3,800	4,000	3,700	3,400	3,200	100
105	5,200	4,500	4,000	3,700	4,000	3,600	3,300	3,100	105
110	5,100	4,400	3,900	3,600	3,900	3,500	3,200	3,000	110
115	4,900	4,200	3,800	3,500	3,800	3,400	3,100	2,900	115
120	4,800	4,100	3,700	3,500	3,700	3,300	3,000	2,800	120
125	4,700	4,000	3,600	3,400	3,600	3,200	2,900	2,700	125
130	4,500	4,000	3,600	3,300	3,400	3,100	2,800	2,700	130
135	4,400	3,900	3,500	3,300	3,300	3,000	2,700	2,600	135
140	4,300	3,800	3,400	3,200	3,200	2,900	2,700	2,500	140
145	4,200	3,700	3,400	3,200	3,100	2,800	2,600	2,500	145
150	4,100	3,600	3,300	3,100	3,000	2,700	2,500	2,400	150
155	4,000	3,500	3,200	3,100	2,900	2,600	2,400	2,300	155
160	3,600	3,400	3,200	3,100	2,800	2,500	2,400	2,300	160
165	3,200	3,400	3,100	3,000	2,700	2,500	2,300	2,200	165
170	2,800	3,300	3,100	3,000	2,600	2,400	2,200	2,200	170
175	2,400	2,900	3,000	3,000	2,400	2,300	2,200	2,100	175
180	2,000	2,500	2,800	2,900	2,000	2,300	2,100	2,100	180
185	1,700	2,100	2,400	2,500	1,700	2,100	2,100	2,000	185
190	1,400	1,800	2,000	2,100	1,300	1,800	2,000	2,000	190
195	1,100	1,400	1,700		1,000	1,400	1,700	1,800	195
200		1,100	1,300			1,100	1,400	1,500	200
205			1,000				1,000	1,100	205

This information is not for crane operation. Operator must refer to the in-cab information for crane operation. Rated lifting capacities shown on fully extended outriggers do not exceed 85% of the tipping loads and on tires do not exceed 75% of the tipping loads.



This Page Intentionally Blank



This Page Intentionally Blank



5759-0416-T2LB

Link-Belt Construction Equipment Company Lexington, Kentucky www.linkbelt.com

®Link-Belt is a registered trademark. Copyright 2016. We are constantly improving our products and therefore reserve the right to change designs and specifications.