



Specifications

Telescopic Boom All Terrain Crane

ATC-822

22-ton (20 metric tons)

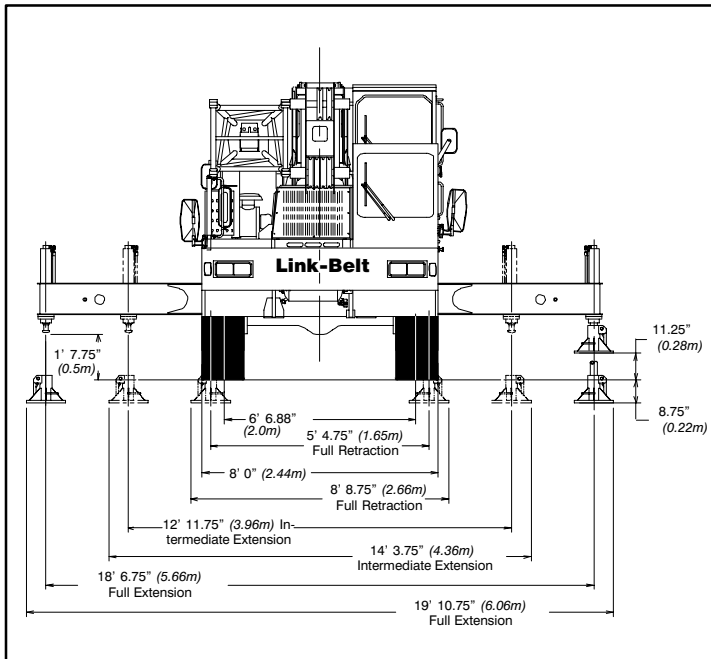
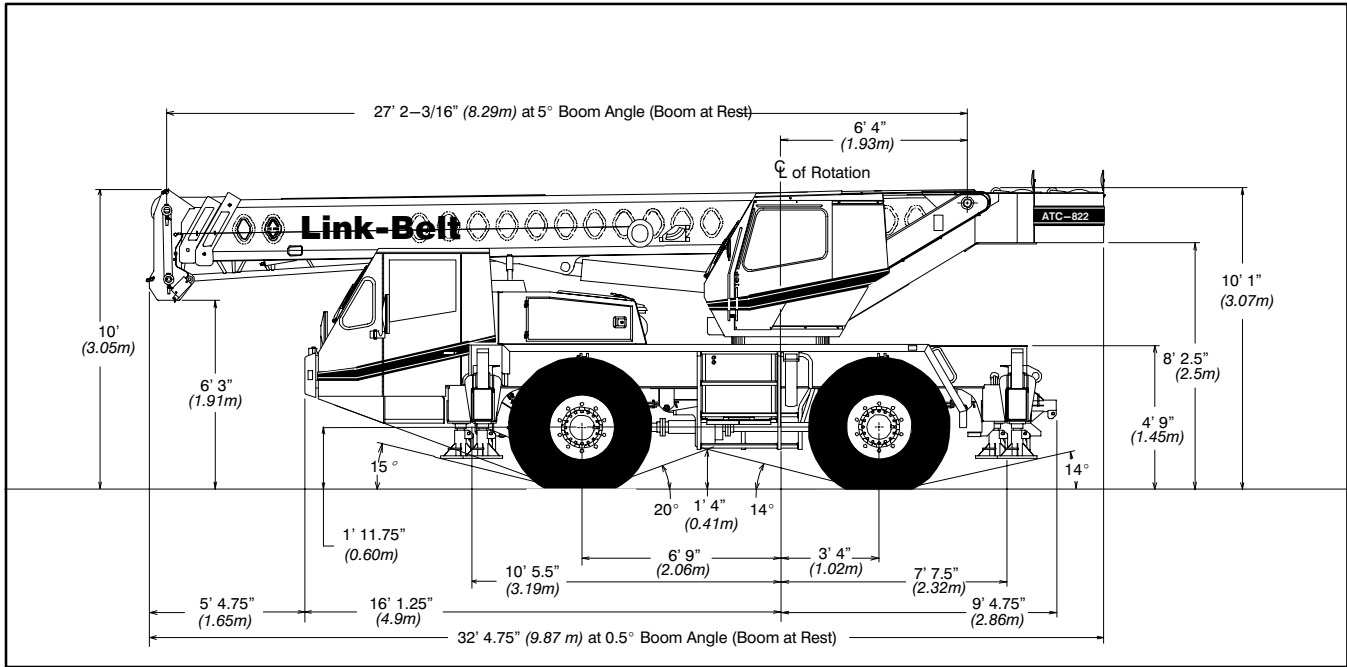

General Dimensions	feet	meters
Turning radius (2-wheel steer)	29' 6"	8.99
Turning radius (4-wheel steer)	17' 6"	5.33
Turning radius (2-wheel steer, wall-to-wall)	32' 0"	9.75
Turning radius (4-wheel steer, wall-to-wall)	23' 6"	7.16
Tailswing	11' 1"	3.38



Link-Belt

CONSTRUCTION EQUIPMENT

Upper Structure

■ Boom

Patented Design

- Boom side plates have diamond shaped impressions for superior strength to weight ratio and 100,000 p.s.i. (689.5 MPa) steel angle chords for lateral stiffness.
- Boom telescope sections are supported by top, bottom and adjustable side wear shoes to prevent metal to metal contact.

Standard Boom

- 27.12' to 70.12' (8.27 – 21.37 m) three-section full power boom.
- Mechanical Boom Angle Indicator

Boom Head

- Four 10 – 5/8" (0.27 m) root diameter non-metallic head sheaves handle up to eight parts of wire rope.
- Boom head is designed for quick reeve of hookblock.
- Rope dead end lugs provided on each side of boom head.
- Two, easily removable wire rope guards.

Boom Elevation

- One Link-Belt designed hydraulic cylinder with holding valve and bronze bushing in each end.
- Hand control for controlling boom elevation from –3° to 78°.

Optional Auxiliary Lifting Sheave

- Single 10–5/8" (0.27 m) root diameter non-metallic sheave with removable wire rope guard.
- Use with one or two parts of line off the optional auxiliary winch.
- Does not affect erection of fly or use of main head sheaves for multiple reeving.

Optional

- 25-ton (22.7 mt) 3-sheave, quick reeve hook block.
- 5-ton (4.5 mt) hook ball.
- Boom floodlight.

■ Fly

Optional

- 27' (8.23 m) One-piece lattice fly, stowable, offsettable to 2°, 20° or 40°.
- 27' to 44' (8.23 to 13.41 m) Two-piece (bi-fold) lattice fly, stowable, offsettable to 2°, 20° or 40°.

■ Cab and Controls

Environmental Cab

- Isolated from sound with acoustical foam insulation.
- Six-way adjustable operator's seat with retractable seat belt.
- All windows are tinted and tempered safety glass.
- Slide by door opens to 28" (0.71 m) width.
- Sliding rear and right side windows and swing up roof windows for maximum visibility and ventilation.
- Audible swing alarm.
- Backup alarm
- Mirrors
- Top hatch window wiper
- Warning horn
- Working lights
- Defrost
- Cup holder

- Fire extinguisher
- Dome light
- Front and rear steer indicator
- Windshield wiper and washer
- Engine monitoring system
- Circulating fan
- Sun screen

Optional

- Amber strobe light
- Amber rotating beacon
- 360° cab-mounted spotlight
- Diesel or hydraulic cab heater

Controls

Carrier Remote Control Steering – Standard – Relay switch design prevents operation of upper crane functions if crane is started from the carrier. If crane is started from the upper the carrier functions will not operate.

- Upper cab contains rear-axle steering wheel.
- Toggle switch for front-axle steer
- Upper shift for four forward and one reverse speeds.
- Top speed when operating from upper cab is 37 m.p.h. (59.5 km/hr).
- Top reverse speed when operating from upper cab is 6 m.p.h. (9.7 km/hr).

Dual-axis, pilot-operated, hydraulic controls (joystick type) for:

- Main winch
- Optional auxiliary winch
- Outrigger controls located on dash and and sight level bubble also provided in upper cab.
- Boom hoist
- Swing

Foot controls for:

- Boom telescope
- Service brake
- Swing brake
- Engine throttle

Cab Instrumentation

Dash mounted gauges for:

- Hydraulic oil temperature
- Transmission temperature
- Water temperature
- Converter temperature
- Tachometer
- Oil pressure
- Fuel
- Voltmeter
- Air pressure

■ Rated Capacity Limiter

- **Microguard 434** Graphic audio-visual warning system built into dash with anti-two block and function limiters.

Operating data available includes:

- Machine configuration.
- Boom length
- Head height
- Allowed load
- % of allowed load
- Boom angle
- Radius of load
- Actual load

Pre-settable alarms include:

- Maximum and minimum boom angles.
- Maximum tip height.
- Maximum boom length.
- Swing left/right positions.
- Operator defined area alarm is standard.
- Anti-two block weight designed for quick reeve of hookblock.

Optional

- **Internal RCL light bar:** Visually informs operator when crane is approaching maximum load capacity with a series of three lights; green, yellow and red.

- **External RCL light bar:** Visually informs ground crew when crane is approaching maximum load capacity kickouts and pre-settable alarms with a series of three lights; green, yellow and red.

■ Swing

- Bi-directional hydraulic swing motor mounted to a planetary reducer for 360° continuous smooth swing at 2.0 r.p.m.
- **Swing parking brake** – Foot operated, manually applied/released disc brake mounted on the speed reducer.
- **Swing brake** – Foot operated, spring released disc brake mounted on the speed reducer.
- **Swing lock** – Standard; two position travel lock operated from the operator's cab.
 - Optional – 360° swing lock.
- **Counterweight** – Bolted to upper structure frame.
 - 1,500 lbs. (680 kg) for a two-drum machine.
 - 2,365 lbs. (1 073 kg) for a one-drum machine.
 - Optional – additional 1,500 (680 kg) counterweight.

Optional

- 360° swing lock (meets New York City requirements).

■ Hydraulic System

Main Pump

- Three-section gear-type pump.
- Combined pump capacity 75 gpm (283.8 lpm).
- Driven off of transmission.
- Pump disconnect for cold-weather starting.
- Two pumps operate at 3,500 p.s.i. (246 kg/cm²) and a third operates at 2,600 p.s.i. (183 kg/cm²).

Steering Pump

- Single section rear pump, 20 gpm (75.7 lpm) maximum. Powered by carrier engine through an auxiliary pump drive.
- Pump operates at 2,000 p.s.i. (141 kg/cm²).

Reservoir

- 63 gal. (238.5 L) capacity. Single diffuser for deaeration.

Filtration:

- One 10-micron filter located outside hydraulic reservoir.
- Accessible for easy replacement.

Control Valves:

- Five separate control valves allow simultaneous operation of all crane functions.

Oil Seals

- Redundant oil seal technology incorporates 3-rod sealing surfaces on boomhoist, boom extend/retract, outrigger jack and oscillation cylinders.

(continued on next page)



(Upper Structure continued)

Load Hoist System

Standard

- 1M main winch with lagging.
- Single-speed motor and automatic brake.
- Power up/down mode of operation with hoist drum cable follower.

- Bi-directional piston-type hydraulic motor, driven through a planetary reduction unit for positive operator control under all load conditions.
- Electronic drum indicators.
- Asynchronous parallel double crossover grooved drums minimize rope harmonic motion.

- 350' (106.68 m) 5/8", 18 x 19, rotation resistant wire rope.

Line Pulls and Speeds

- Maximum line pull 9,080 lbs. (4 118 kg) and maximum line speed of 293 f.p.m. (89.30 m/min) on standard 10–5/8" (0.27 m) root diameter grooved drum.

Carrier

Type

- 8' 0" (2.44 m) wide, 121" (3.07 m) wheelbase.
- 4 x 4 x 4 – (4-wheel steer, 4-wheel drive) For rough terrain with limited turning area.

Frame

- 100,000 p.s.i. (689.5 MPa) steel, double walled construction.
- Integral 100,000 p.s.i. (689.5 MPa) steel outrigger boxes.

Standard Carrier Equipment

- Two front and two rear carrier steps.
- Battery box and engine compartment
- Skid-resistant finish on carrier deck.
- Air-cleaner service indicator
- Carrier mounted travel lights
- Desiccant type air dryer
- Cab access steps
- Full deck fenders
- Locking storage
- Back-up alarm
- Towing lugs
- Mud flaps

Optional

- Front and rear towing shackles.
- Rear mounted pintle hook.

Engine

Engine	Cummins ISB 230
Cylinders – cycle	6 – 4
Bore	4.02 in. (102.11 mm)
Stroke	4.72 in. (119.89 mm)
Displacement	359 cu. in. (5 884 cm ³)
Maximum brake hp	230 @ 2500 rpm
Peak torque (ft. lb.)	605 @ 1500 rpm
Electric system	12 volt
Fuel capacity	40 gallons (151.4 L)
Alternator	130 amps
Crankcase capacity (total system)	17.3 qts. (16.37 L)
<ul style="list-style-type: none"> • Charge air cooled • Dual battery system • 110-volt block heater 	

Transmission

- ZF automatic or full power shift.
- Six speeds forward and three reverse.
- Integral transmission and torque convertor
- Front axle disconnect for two or four-wheel drive.

Axles

- Front and Rear – Heavy duty planetary drive/steer type with differential lock.
- Rear axle also includes rear steer lock.

Suspension

Front and Rear Axle

- Front and rear axle oscillation.
- Leaf spring suspension.
- Lock out cylinders serve as shock absorbers.

- Suspension automatically locks when operating from upper cab, except when upper cab is directly over rear.
- Front axle unlocks for pick and carry operations

Steering

- Independent, hydraulic two-wheel, four-wheel and "crab" steering.
 - **Front axle** – Sheppard steering controlled by steering wheel in carrier cab and toggle switch in upper cab.
 - **Rear axle** – Orbital steering unit by steering wheel in upper cab and toggle switch in carrier cab.

Tires

Front and Rear

- Standard 16.0 R 20, AT-2A (load range "M"), tubeless

Optional

- 17.5 R 25, XHC-2 star, tubeless.
- Spare tires and rims.

Brakes

Service

- Full air on all wheels; drum-type brakes at each wheel end.
 - **Front** – Dual leading wedge type; drum diameter 16 1/8" (0.41 m). Shoe width 7" (0.18 m). Two brake chambers per wheel.
 - **Rear** – Single leading wedge type; drum diameter 16 1/8" (0.41 m). Shoe width 7" (0.18 m). One brake chamber per wheel.

Parking/Emergency

- Spring applied, pneumatic released, upper and carrier cab controlled, mounted on rear axle.

Outriggers

- Three position operation capability.
- Four hydraulic, telescoping beam and jack outriggers.
- Vertical jack cylinders equipped with integral holding valve.
- Beams extend to 18.5' (5.7 m) centerline-to-centerline and retract to within 8' (2.4 m) overall width.
- Equipped with stowable, lightweight 16" (0.41 m) diameter aluminum floats.
- Controls and sight level bubble located in upper cab.

Confined Area Lifting Capacities (CALC™) System

- The crane is operational in one of the three outriggers positions and operational in confined areas in two positions (intermediate and full retraction). The three outrigger positions are:

- Full extension – 18' 6–3/4" (5.66 m).
- Intermediate position – 12' 11–3/4" (3.96 m).
- Full retraction – 7' 4–3/4" (2.3 m).
- Capacities are available with the outrigger beams in the intermediate and full retraction positions.
- When the outrigger position levers (located on the outrigger beams) are engaged, the operator can set the crane in the intermediate or full retraction outrigger position without having to leave the cab.

Electrical System

- Two 12-volt batteries.
- 800 cold cranking amps.
- 130 amp alternator.
- Automotive type wiring with sealed connectors.

Lights

- Four dual-beam sealed headlights.
- Front and rear directional signals.
- Four-way emergency flashers.
- Stop and tail lights.
- Back-up lights.
- Clearance lights.
- License plate lights.

Carrier Cab

- One-man cab, rubber mounted for vibration and sound insulation, equipped with:
- Six-way adjustable seat with seat belt
- Tilt/telescoping steering wheel
- Sliding right and rear tinted windows.
- Roll up/down left hand tinted door window.
- Rear view mirror
- Wiper and washer
- Dome and dash lights
- Horn
- 36,000 BTU heater
- Defroster
- Door lock
- Fire extinguisher

Cab Instrumentation – Equipped with:

Illuminated instrument panel

- Engine water temperature gauge
- Fuel level gauge
- Engine oil pressure gauge
- Front and rear air system pressure gauges
- Transmission oil temperature gauge
- Voltmeter
- Tachometer
- Hourmeter
- Speedometer
- Odometer
- Driving light switch
- High beam indicator light
- Turn signal indicator light
- Heater/defroster switch and temperature control
- Rear axle steer switch and indicator gauge
- Rear axle steer lock switch with indicator light
- Park brake valve with indicator light
- Rear axle differential lock switch with indicator light
- 4-wheel drive switch.



Link-Belt

CONSTRUCTION EQUIPMENT

Travel Speeds and Gradability

Engine	Tires	Maximum Speed		*Gradability at stall	Maximum tractive effort at stall		Gradability at 1.0 mph (1.6km/h)	Maximum tractive effort at 1.0 mph (1.6km/h)	
		mph	km/h		lbs	kg		lbs.	kg
Cummins ISB230	16.0R20	55.0	88.5	63.0	23,343	10 588	56.9	21,354	9 685
	17.5R25	55.0	88.5	60.0	23,021	10 442	54.2	20,827	9 447

Axle Loads

Base machine with standard 27.12' — 70.12' (8.27 m — 21.37 m) three-section boom, 350' (106.68 m), 5/8" (16 mm) wire rope, 4 x 4 x 4 carrier with Cummins ISB230 engine, 16.0R20 tires, full of fuel and counterweight.	G.V.W. ¹		Upper facing front				Upper facing rear			
			Front axle		Rear axle		Front axle		Rear axle	
	lbs.	kg.	lbs.	kg.	lbs.	kg.	lbs.	kg.	lbs.	kg.
	39,223	17 791	19,963	9 055	19,260	8 736	17,772	8 061	21,451	9 730
Ether injector for engine	14	6	16	7	-2	-1	16	7	-2	-1
Rear carrier mounted towing winch	370	167	-167	-75	537	243	-167	-75	537	243
17.5R25 tires	480	218	240	109	240	109	240	109	240	109
Driver in carrier cab	200	91	300	136	-100	-45	300	136	-100	-45
Rear carrier mounted pintle hook	25	11	-14	-6	39	18	-14	-6	39	18
Diesel heater with fuel in operator's cab	70	32	8	4	62	28	39	18	31	14
Hydraulic heater in operator's cab	110	50	12	5	98	44	61	28	49	22
Deduct 350' (106.68 m) of wire rope from front winch	-257	-116	173	78	-430	-195	-343	-156	86	39
Rear winch roller	60	27	-35	-16	95	43	75	34	-15	-7
Power up/down front winch w 350' (106.68 m) of rope	4	2	-1	-0.5	5	2	4	2	0	0
Deduct 350' (106.68 m) of wire rope from front winch	-257	117	124	56	-381	-173	-294	-133	37	17
Front winch roller	60	27	-24	-11	84	38	63	29	-3	-1
360° mechanical (pin-on shear) swing lock	15	7	7	3	8	4	3	1	12	5
1,500 lbs. (680 kg) of counterweight	1,500	680	-935	-424	2,435	1 105	1,927	874	-427	-194
Fly brackets to boom base section for fly options	106	48	96	44	10	5	-26	12	132	60
27' (8.23 m) offsettable lattice fly (stowed)	1,052	477	1,243	564	-191	-87	-548	248	1,600	726
27' — 44' (8.23 m — 13.14 m) offsettable lattice fly stowed (stowed)	1,475	669	1,516	688	-41	-19	-541	248	2,016	914
Boom floodlight	10	5	18	8	-8	-4	-11	-5	21	10
22-ton (20 mt) Hookblock stowed at boom head (3 sheave)	670	304	1,607	729	-937	-425	-1,164	-528	1,834	832
22-ton (20 mt) Hookblock stowed in the front storage compartment (3 sheave)	670	304	1,138	516	-468	-212	1,138	516	-468	-212
22-ton (20 mt) Hookblock stowed in the rear storage compartment (3 sheave)	670	304	-169	-77	839	381	-169	-77	839	381
5-ton (4.5 mt) Hookball at the boom head	189	86	462	210	-273	-124	-337	-153	526	239
5-ton (4.5 mt) Hookball in front storage compartment	189	86	321	147	-132	-60	321	147	-132	-60
5-ton (4.5 mt) Hookball in rear storage compartment	189	86	-48	-22	237	108	-48	-22	237	108
Auxiliary lifting sheave	110	50	274	124	-164	-74	-201	-91	311	141

¹ Adjust gross vehicle weight and axle loading according to component weight.

Note: All weights are ± 3%

Tire	Max. Load @ 55 mph (88.50 km/hr)
16.0 R 20	22,800 lbs. (10 342 kg)
17.5 R 25	22,800 lbs. (10 342 kg)

Link-Belt Construction Equipment Company Lexington, Kentucky www.linkbelt.com

©Link-Belt is a registered trademark. Copyright 2000. All rights reserved. We are constantly improving our products and therefore reserve the right to change designs and specifications.