



Technical Data

Specifications & Capacities

108 HYLAB 5

Crawler Crane
50 Ton (50 metric ton)

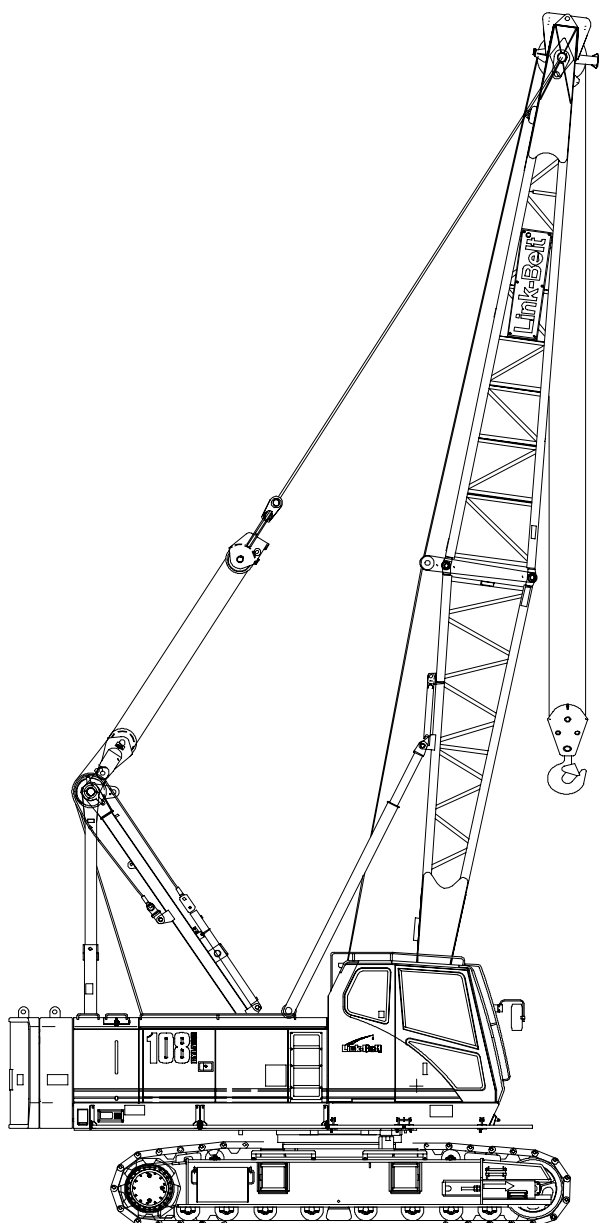

CAUTION: This material is supplied for reference use only. Operator must refer to in-cab Crane Rating Manual and Operator's Manual to determine allowable crane lifting capacities and assembly and operating procedures.



5495 (supersedes 5462)–0906–N8



Table Of Contents

Upper Structure	1
Frame	1
Engine	1
Hydraulic System	1
Load Hoist Drums	1
Optional Third Hoist Drum	1
Optional Fourth Hoist Drum	1
Boom Hoist Drum	2
Boom Hoist System	2
Swing System	2
Counterweight	2
Operator's Cab	2
Rated Capacity Limiter System	2
Machinery Cab	2
Catwalks	2
Lower Structure	2
Carbody	2
Side Frames	2
Travel and Steering	3
Attachment and Options	3
Conventional Angle Boom	3
Tubular Jib	3
Auxiliary Tip Extension	3
Pile Driver Lead Adaptor	3
Boom Folding Equipment	3
Dimensions	4
Base Crane	6
Side Frames	6
Counterweights	6
Boom	7
Jib	8
Hook Balls	9
Hook Blocks	9
Fairleader	9
Transport Weights	10
Working Weights	11
Transport Drawings	11
Load Hoist Performance	12
Working Areas	13
Attachments	14
Main Boom Make-up	15
Duty Cycle Working Range Diagrams	16
Duty Cycle Load Charts	18
Main Boom Working Range Diagram	19



5495 (supersedes 5462)–0906–N8

Main Boom Load Charts	20
Jib Attachment Make–up	22
Jib Attachment Working Range Diagram	23
Jib Attachment Load Charts	24



Upper Structure

Frame

All welded and precision machined surfaces.

Turntable Bearing

- Inner race with internal swing gear is bolted to lower frame
- Outer race bolted to upper frame

Engine

Engine

Full pressure lubrication, oil filter, air cleaner, hour meter, throttle, and electric control shutdown.

Isuzu AH-4HK1X

Number of cylinders	4
Bore and stroke	4.53 in x 4.92 in (115 x 125mm)
Piston displacement	317 in ³ (5.2L)
Engine rpm at full load speed	2,100 rpm
Hi-idle rpm	2,100 rpm
Gross engine hp	200 hp (148.4kw)
Peak torque	507 ft lb (688joule) @ 1,500 rpm
Electrical system	24 volt
Fuel tank capacity	77 gal (291.5L)
Batteries	2-12 volt
Approximate fuel consumption	gal/hr (L/hr)
100% hp	10.42 (39.44)
75% hp	8.20 (31.04)
50% hp	6.06 (22.94)
25% hp	3.03 (11.50)

Fuel Tank

Equipped with fuel sight level gauge, flame arrester, and self-closing cap with locking eye for padlock.

Hydraulic System

Hydraulic Pumps

The pump arrangement is designed to provide hydraulically powered functions allowing positive, precise control with independent or simultaneous operation of all crane functions.

- Two variable displacement pumps operating at 4,270 psi (300kg/cm²) and 64 gal/min (296L/min) powers load hoist drums, boom hoist drum, optional third drum, and travel.
- One fixed displacement gear type pump operating at 3,000 psi (210kg/cm²) and 29 gal/min (111L/min) powers the swing motor and retract cylinders.
- One fixed displacement gear type pump operating at 1,200 psi (85kg/cm²) and 6.6 gal/min (25L/min) powers the remote control valves and counterweight lifting cylinders.

Pump Control “Fine Inching” Mode

Special pump setting, selectable from the operator’s cab, that allows very slow movements of load hoist drums, boom hoist drum, and travel for precision work.

Hydraulic Reservoir

77 gal (291L), equipped with sight level gauge. Diffusers built in for deaeration.

Filtration

Ten micron, full flow, line filter in the control circuit. All oil is filtered prior to entering the reservoir.

Counterbalance Valves

All hoist motors are equipped with counterbalance valves to provide positive load lowering and prevent accidental load drop if the hydraulic pressure is suddenly lost.

Load Hoist Drums

Each drum contains a pilot controlled, bi-directional, axial piston motor and a planetary gear reduction unit to provide positive control under all load conditions.

- Power up/down and free-fall operation modes
- Automatic brake mode (spring applied, hydraulically released, band type brake)
- Grooved lagging
- Drum pawl controlled manually
- Electronic drum rotation indicators
- Mounted on anti-friction bearings
- 15.75 in (40.00cm) root diameter
- 31.50 in (80.00cm) flange diameter
- 16.09 in (40.87cm) width

- Bolt on spiral lagging for 0.88 in (22.22mm) wire rope. Bolts to the flange of front hoist drum. Used for dragline work.

The free-fall operation mode is designed to prevent load lowering even if the free-fall switch is accidentally activated.

The automatic brake mode meets all OSHA requirements for personnel handling.

Drum Clutches

Hydraulic two shoe clutch design that uses a 20 in (50.8cm) diameter x 5 in (12.7cm) wide shoe that expands internally to provide load control. Swept area is 314 in² (2 026cm²).

Drum Brakes

External contracting band design that uses a 31.5 in (80.01cm) diameter x 4.7 in (11.9cm) wide shoe. Spring applied, hydraulically released “automatic brake mode” or mechanical foot control.

Optional Third Hoist Drum

Mounts to the front or rear of the upper frame and is used in conjunction with a fleeting sheave and 3-sheave idler assembly to run the wire rope over the boom top section.

- Free-spooling capability for pile driving applications
- 10.63 in (27.0cm) root diameter
- 20 in (50.8cm) flange diameter
- 13.5 in (34.3cm) width
- Mounted on anti-friction bearings

Optional Fourth Hoist Drum

Mounts to the rear of the upper frame with gravity free fall for use in pile driving applications.

- 15.75 in (40.0cm) root diameter
- 31.50 in (80.0cm) flange diameter
- 10.63 in (27.0cm) width
- Mounted on anti-friction bearings



Boom Hoist Drum

Contains a pilot controlled, bi-directional, axial piston motor and a planetary gear reduction unit to provide positive control under all load conditions.

- Spring applied, hydraulically released, disc type brake controlled automatically
- Drum pawl controlled automatically
- Mounted on anti-friction bearings
- 12.6 in (32.0cm) root diameter
- 24.41 in (62.0cm) flange diameter
- 9.57 in (24.3cm) width

Boom Hoist System

Designed to lift off maximum boom or maximum boom plus jib unassisted. Operates up to a maximum boom angle of 82°. Boom hoist limit system limits maximum boom angle operation.

- Retractable gantry frame
- Pin-on bail frame
- 14-part reeving with 5/8 in (15.88mm) wire rope
- Bridle assembly
- Two 1.125 in (28.70mm) pendants
- Tubular boom backstops (telescopic type)
- Nylon sheaves contain sealed anti-friction bearings
- Boom speed from 0°–82° is 60 seconds with no load.

Swing System

Pilot controlled bi-directional axial piston motors and planetary gear reduction units to provide positive control under all load conditions.

- Spring applied, hydraulically released, 360° multi-plate brake
- Free swing mode when lever is in neutral position

- Two position positive house lock
- Audio/Visual swing alarm
- Maximum swing speed is 3.4 rpm

Counterweight

Consists of a two-piece design that can be easily lowered to the ground using the gantry.

- “A” counterweight consists of one, 14,000 lb (6 350kg) base slab
- Optional “B” counterweight consists of one, 10,000 lb (4 535kg)
- Optional “XL” counterweight package offers increased capacities for lift and piling applications. It consists of one, 4,630 lb (2 100kg) upper counterweight and two, 4,300 lb (1 950kg) side frame counterweights. *Not for duty cycle application. Not designed to self-assemble.*

Operator’s Cab

Fully enclosed modular steel compartment is independently mounted and padded to protect against vibration and noise.

- All tinted/tempered safety glass
- Sliding entry door and front window
- Door and window locks
- Hot water heater
- Air conditioner
- Sun visor
- Cloth seat
- Circulating fan
- Windshield wipers and washer
- Dry chemical fire extinguisher
- Engine instrumentation panel (tachometer, voltmeter, engine oil pressure, engine water temperature, fuel level, hydraulic oil temperature, hour meter, and service monitor system)
- Mechanical drum rotation indicators for front and rear hoist drums
- Six way adjustable seat

- Hand and foot throttle
- Fully adjustable single axis controls
- Swing lever with swing brake and horn located on handle
- Bubble type level
- Ergonomic gauge layout
- Controls shut off lever
- Right hand control stand is adjustable by electric motor for operator comfort.

Rated Capacity Limiter System

The rated capacity limiter system is a boom hoist load cell system. This system provides the operator with useful geometrical data, to include:

- Main Boom Length
- Main Boom Angle
- Jib Length
- Jib Angle
- Operating Mode
- Load Radius
- Boom Tip Height
- Audible Alarm
- Pre-Warning Light
- Overload Light
- Load On Hook
- Function kick-outs including over load
- Operator settable stops (ramped stops)
- Anti-Two Block Indicator
- Boom hoist dead end load cell (no liners)

Machinery Cab

Hinged doors (two on right side, three on left side) for machinery access. Equipped with rooftop access ladder and skid resistant finish on roof.

Catwalks

Standard on right and left sides. Catwalks fold up and pin for reduced travel width.

Lower Structure

Carbody

Lower Frame

All welded box construction frame with precision machined surfaces for turntable bearing and rotating joint.

- 7 ft 9.31 in (2.37m) overall width
- 10 ft 9.12 in (3.28m) overall length

Side Frames

Side Frames

All welded, precision machined, steel frames can be hydraulically extended and retracted by a hydraulic cylinder mounted in the lower frame.

- 11 ft 2 in (3.40m) extended gauge

- 8 ft 8.7 in (2.66m) retracted gauge
- 17 ft 8 in (5.38m) overall length
- 36 in (0.91m) wide track shoes
- Optional 30 in (0.76m) wide track shoes
- Sealed (oil filled) idler and drive planetaries
- Compact travel drives
- Hydraulic self adjusting tracks

**Track Rollers**

- Eight sealed (oil filled) track rollers per side frame
- Heat treated, mounted on anti-friction bearings

Tracks

Heat treated, self-cleaning, multiple hinged track shoes joined by one-piece full floating pins; 50 shoes per side frame

Take Up Idlers

Cast steel, heat treated, self-cleaning, mounted on sealed tapered roller bearings

Travel and Steering**Travel and Steering**

Each side frame contains a pilot controlled, bi-directional, axial piston motor and a planetary gear reduction unit to provide positive control under all load conditions.

- 2-speed travel
- Individual control provides smooth, precise maneuverability including full counter-rotation.

- Spring applied, hydraulically released disc type brake controlled automatically
- Maximum travel speed is 2.36 mph (3.80km/h) in high speed and 1.3 mph (2.09km/h) in low speed.
- Designed to 40% gradeability

Attachment and Options

**Conventional Angle Boom
40–140 ft (12.19–42.67m)****Basic Boom**

40 ft (12.19m) two-piece design that utilizes a 20 ft (6.10m) base section and a 20 ft (6.10m) open throat top section with in-line connecting pins on 42 in (1.06m) wide and 42 in (1.06m) deep centers.

- Boom foot on 45.2 in (1.15m) centers
- 4 x 4 x 0.38 in (101.6 x 101.6 x 9.5mm) T-1 angle chords for base section
- 4 x 4 x 0.31 in (101.6 x 101.6 x 7.87mm) HSLA angle chords for top section
- Top section includes mounting lugs for all optional attachments
- Bridle guide system located on boom base
- Skywalk platform
- Hooks provided on the base section for handling boom
- Two deflector rollers on top section
- Permanent skid pads mounted on top section to protect head machinery
- Four, 18 in, (0.46m) root diameter steel sheaves mounted on sealed anti-friction bearings
- Mechanical boom angle indicator

Boom Extensions

The following table provides the lengths available and the suggested quantity to obtain maximum boom in 10 ft (3.05m) increments. Midpoint pendant connections are not required.

- Deflector roller on top of each section
- Appropriate length pendants
- Maximum tip height of 144 ft (43.90m)

Boom Extensions		Quantity For Max Boom
ft	m	
10	3.05	2
20	6.10	1
30	9.14	2

Optional

- Clam head machinery – Two 18 in (0.46m) root diameter sheaves mounted on sealed anti-friction bearings and rope roller that bolts to the bottom of boom top.
- Drag head machinery – One 18 in (0.46m) root diameter wide mouth drag sheave mounted on greasable bearings. Two 18 in (0.46m) root diameter steel sheaves mounted on sealed anti-friction bearings. Rope roller bolts to bottom of boom top.

**Tubular Jib
20–50 ft (6.10–15.24m)****Basic Tube Jib**

20 ft (6.10m) two-piece design that utilizes a 10 ft (3.05m) base section and a 10 ft (3.05m) top section with in-line connecting pins on 30 in (0.76m) wide and 24 in (0.61m) deep centers.

- 1.5 in (38.1mm) diameter tubular chords
- One 16.5 in (0.42m) root diameter steel sheave mounted on sealed anti-friction bearings

- 10 ft (3.05m) jib extensions are available to provide jib lengths of 30–50 ft (9.14–15.24m) in 10 ft (3.05m) increments
- Jib offset angles at 5°, 17.5°, and 30°
- The maximum tip height of boom + jib is 163 ft (49.68m).

**5 ft (1.5m) Auxiliary
Tip Extension**

Designed to use in place of jib to provide clearance between working hoist lines. The extension is equipped with two nylon 18.12 in (0.46m) root diameter nylon sheaves mounted on sealed anti-friction bearings. Maximum capacity is 9 Tons (8.16mt).

Pile Driver Lead Adaptor

Designed to mount on the boom top section to provide a single 3.63 in (92.1mm) pin connection for fixed leads.

Boom Folding Equipment

Consist of bolt on brackets and pins to allow folding 50 ft (15.24m) or 70 ft (21.34m) of boom for transport.



Dimensions

General Dimensions	English	Metric
Basic Boom	40 ft	12.19m
Minimum Load Radius	8.6 ft	2.62m
Maximum Boom Angle	82°	82°
Track Shoe Width	36 in	0.91m

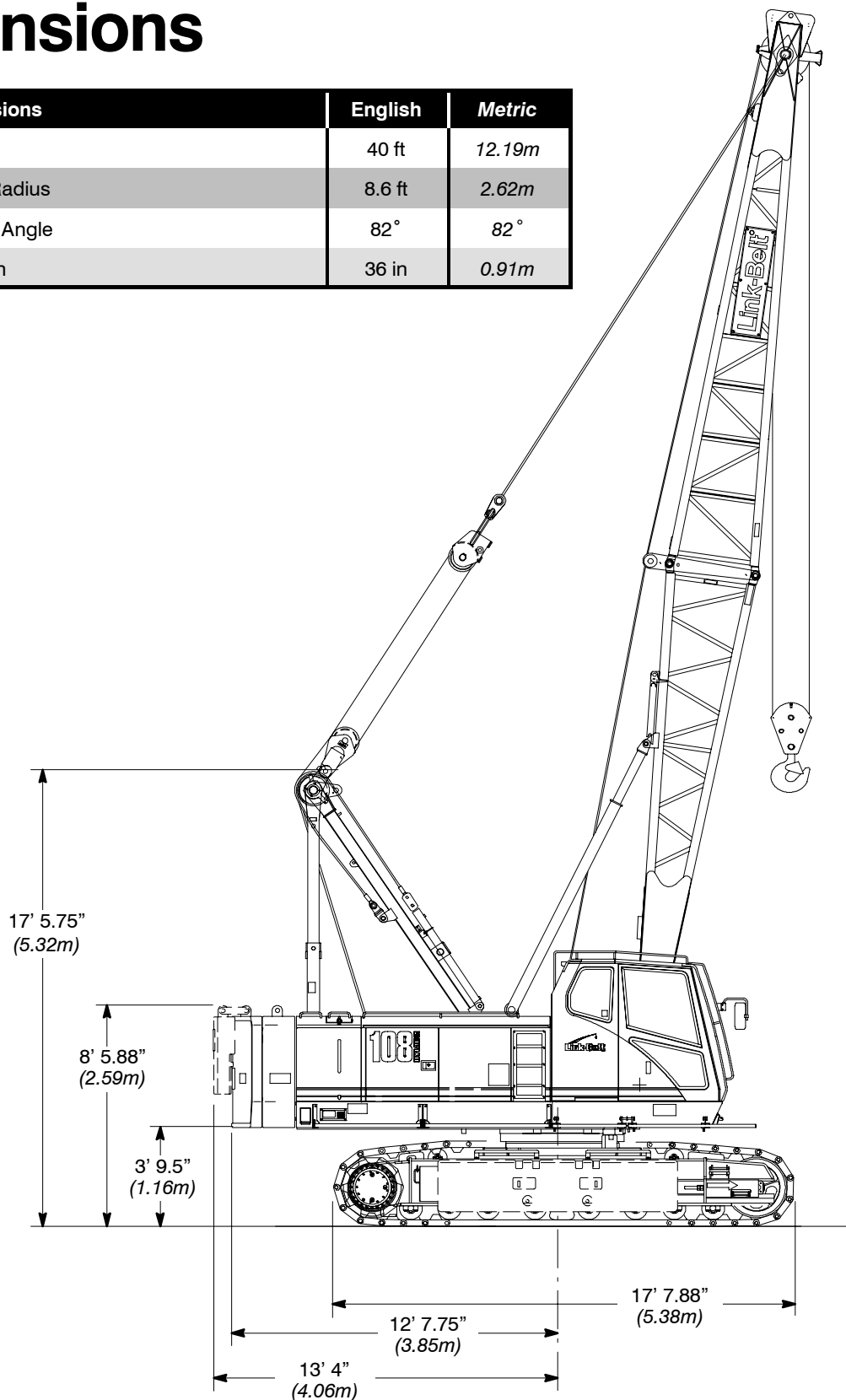

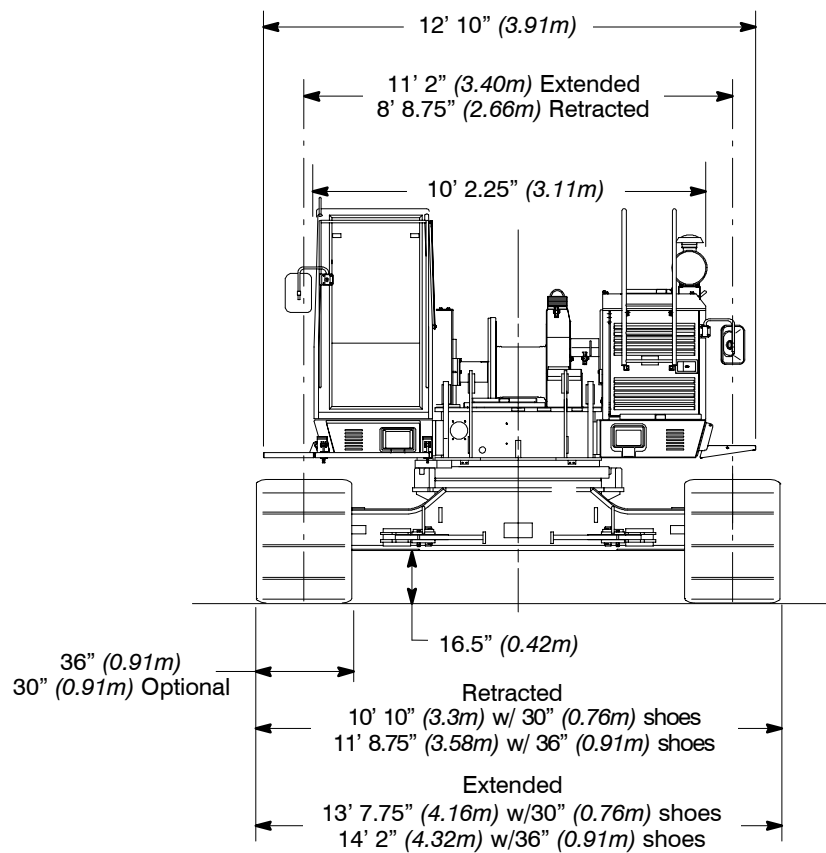
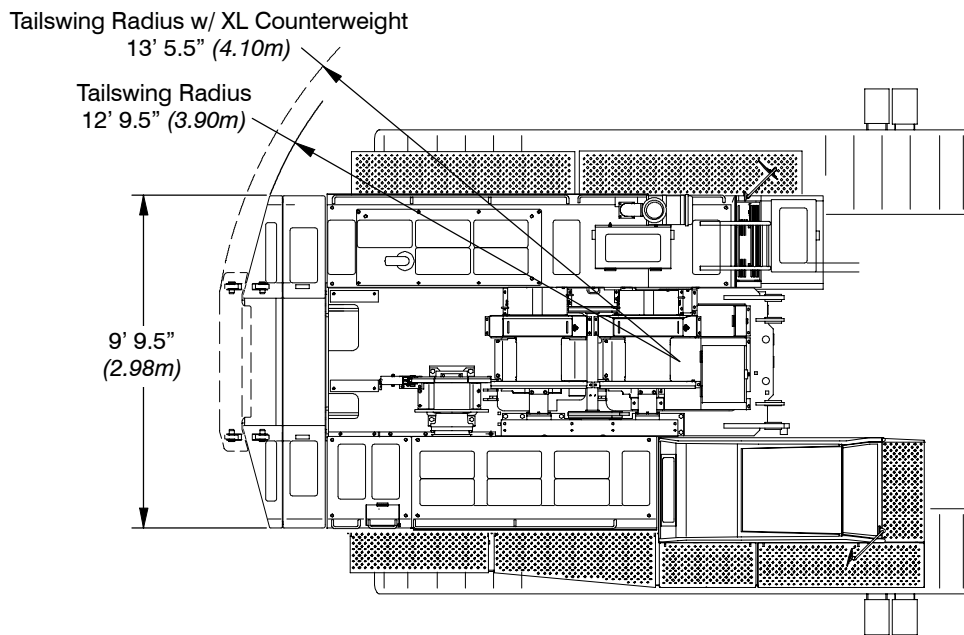



Base Crane

Base Crane ①

Length	38 ft 6 in	(11.73m)
Height	11 ft 2.5 in	(3.42m)
Weight	W/Standard 36 in (0.91m) Track Shoes	
	92,809 lb	(42 097kg)
	W/Optional 30 in (0.76m) Track Shoes	
	89,499 lb	(40 596kg)

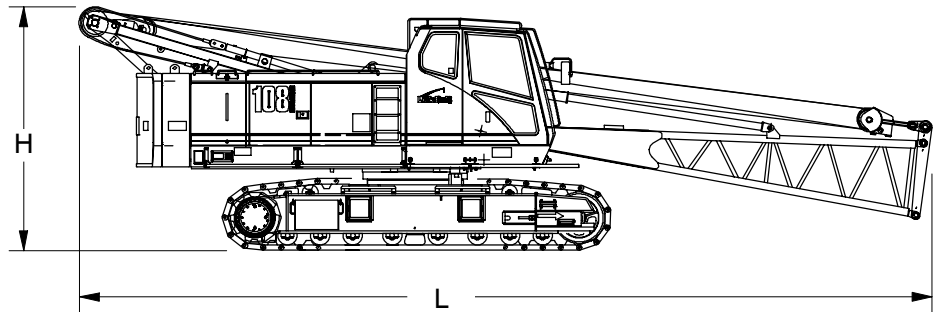

Side Frames

With 36 in (0.91m) Track Shoes ②

Length	17 ft 8 in	(5.38m)
Width	36 in	(0.91m)
Height	39.5 in	(0.92m)
Weight	14,155 lb	(6 421kg)

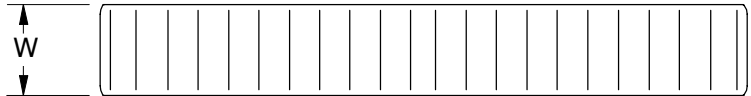

With 30 in (0.76m) Track Shoes ②

Length	17 ft 8 in	(5.38m)
Width	30 in	(0.76m)
Height	39.5 in	(0.92m)
Weight	12,500 lb	(5 670kg)

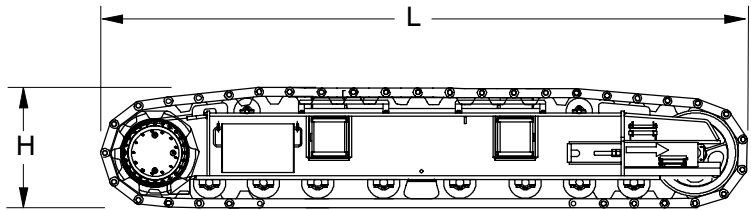

Counterweights

“A” Counterweight ①

Length	117.25 in	(2.98m)
Width	14.5 in	(0.37m)
Height	51.2 in	(1.30m)
Weight	14,000 lb	(6 350kg)

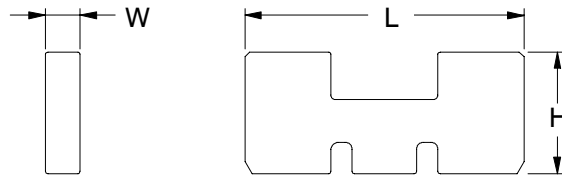

“B” Counterweight ①

Length	117.25 in	(2.98m)
Width	14 in	(0.36m)
Height	51.2 in	(1.30m)
Weight	10,000 lb	(4 536kg)

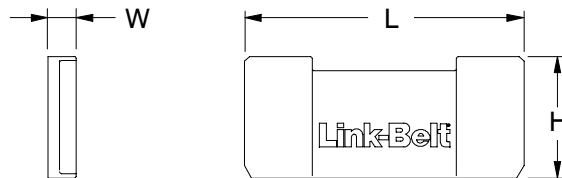

“XL” Side Frame Counterweight ②

Length	110.25 in	(2.8m)
Width	10 in	(0.26m)
Height	23.62 in	(0.6m)
Weight	4,300 lb	(1 950kg)

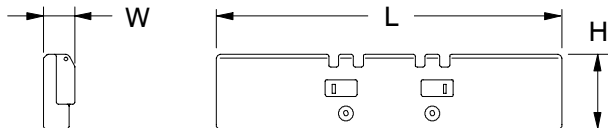

“XL” Upper Counterweight ①

Length	63.00 in	(1.6m)
Width	11 in	(0.28m)
Height	41 in	(1.04m)
Weight	4,630 lb	(2 100kg)

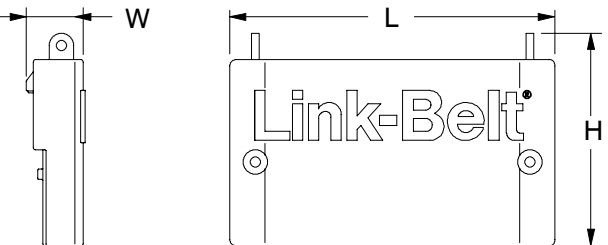

Number inside black circle “①” = # of components



5495 (supersedes 5462) – 0906 – N8

Boom

42 in (1.06m) x 42 in (1.06m)

Boom Extensions

Weights Include Pendants and Hardware

10 ft (3.05m) Extension

Weight: 781 lb (354kg)

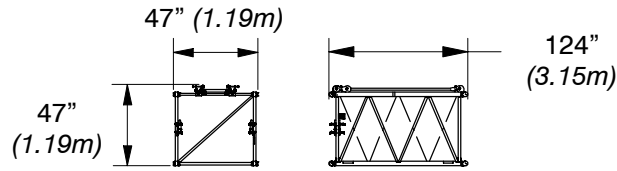

20 ft (6.10m) Extension

Weight: 1,335 lb (606kg)

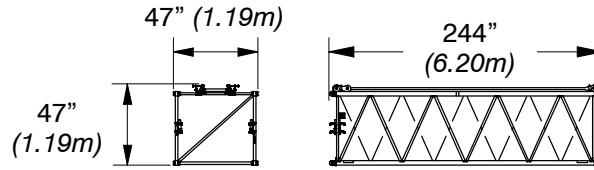

30 ft (9.14m) Extension

Weight: 1,832 lb (831kg)

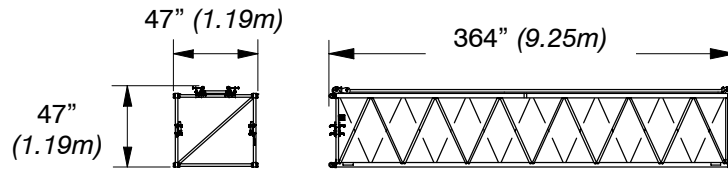

20 ft (6.10m) Boom Top Section

①

Length	21 ft 10 in	(6.65m)
Width	50 in	(1.27m)
Deep	39.75 in	(1.01m)
Height	43.75 in	(1.11m)
Weight	2,711 lb	(1 230kg)

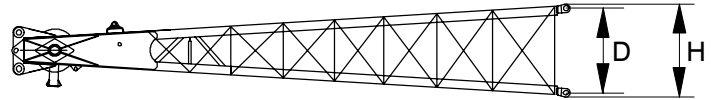
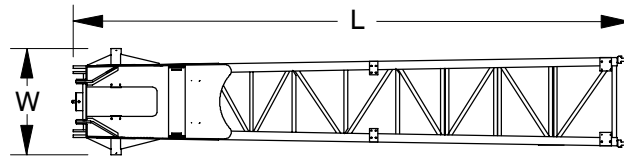

20 ft (6.10m) Boom Base Section

①

Length	20 ft 7 in	(6.27m)
Width	50 in	(1.27m)
Deep	39.75 in	(1.01m)
Height	62.00 in	(1.57m)
Weight	2,217 lb	(1 006kg)

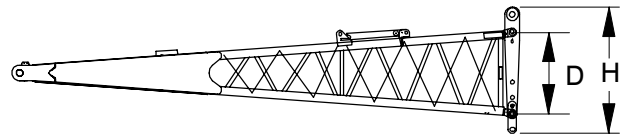
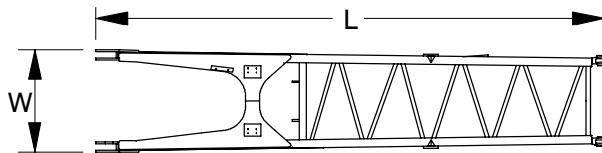

Number inside black circle "①" = # of components



5 ft (1.52m) Auxiliary Tip Extension* ①

Length	5 ft 8.75 in	(1.75m)
Width	24 in	(0.61m)
Height	3 ft 5 in	(1.04m)
Weight	641 lb	(291kg)

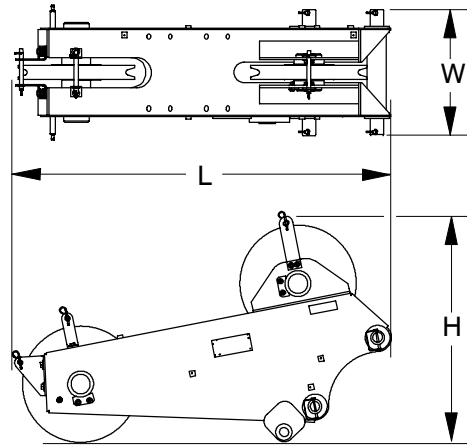

Jib 10 ft (3.05m) Jib Top Section* ①

Length	11 ft 2 in	(3.40m)
Width	31.38 in	(0.80m)
Height	26 in	(0.66m)
Weight†	383 lb	(174kg)

† Weight includes pendants and hardware.

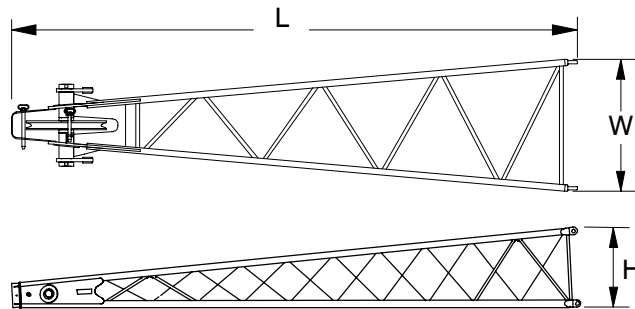

10 ft (3.05m) Jib Base Section* ①

Length	10 ft 3.25 in	(3.13m)
Width	31.75 in	(0.81m)
Height 1	26 in	(0.66m)
Height 2	47.67 in	(1.21m)
Weight†	676 lb	(307kg)

† Weight includes pins, basic frontstay & backstay pendants, and hardware.

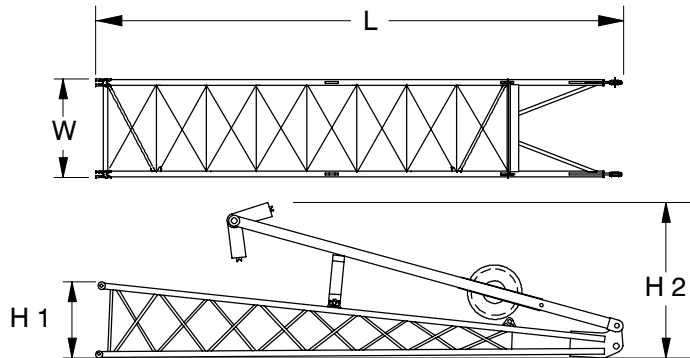

10 ft (3.05m) Jib Extension* ①

Length	10 ft 2 in	(3.10m)
Width	31.75 in	(0.81m)
Height	28.50 in	(0.72m)
Weight†	195 lb	(88kg)

† Weights includes pins, pendants, and hardware.

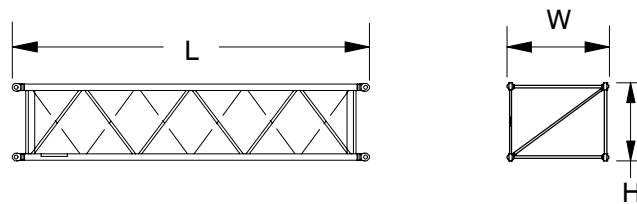

Number inside black circle “①” = # of components

* – Optional equipment



Hook Balls

8.5 Ton (7.7mt) Swivel

Hook Ball* ①

Width	14.5 in	(0.37m)
Height	33.8 in	(0.86m)
Weight	360 lb	(163kg)

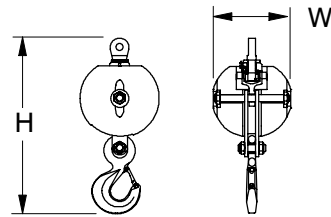

8.5 Ton (7.7mt) Non-Swivel

Hook Ball* ①

Width	16.5 in	(0.42m)
Height	35.00 in	(0.89m)
Weight	360 lb	(163kg)

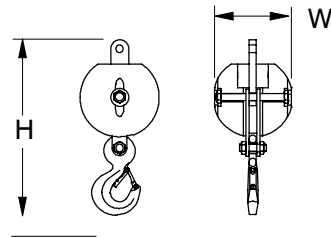

Hook Blocks

40 Ton (36.3mt)

4-Sheave Hook Block* ①

Width1	14.44 in	(0.37m)
Width2	17.88 in	(0.45m)
Width3	15.00 in	(0.38m)
Height	47.95 in	(1.22m)
Weight	780 lb	(354kg)

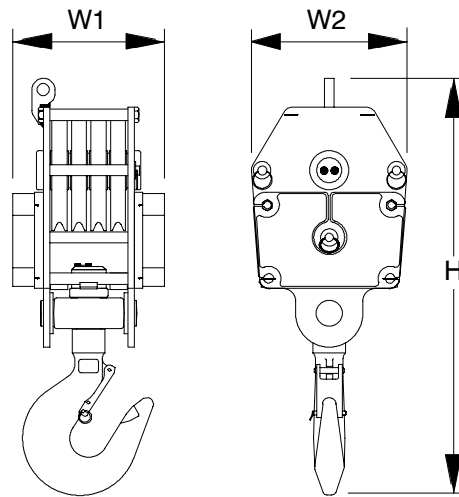

60 Ton (54.4mt)

4-Sheave Hook Block* ①

Width1	20.13 in	(0.51m)
Width2	20 in	(0.51m)
Height	50 in	(1.27m)
Weight	1,110 lb	(503kg)

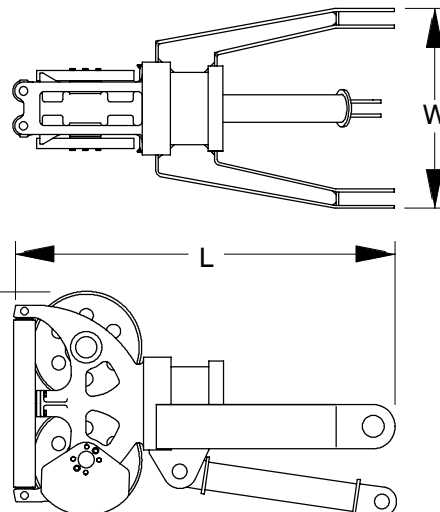

Fairleader

Fairleader* ①

Length	62.00 in	(1.57m)
Width	32.25 in	(0.82m)
Height	36.25 in	(0.92m)
Weight	1,274 lb	(578kg)

Number inside black circle "①" = # of components

* – Optional equipment



Transport Weights

Base Crane: Rigid boom backstops, 77 gal (291L) of fuel, catwalks (left and right side), 20 ft (6.10m) base section, bridle/spreader bar, boom hoist reeving, 600 ft (182.88m) of type 'DB' front hoist rope, 500 ft (152.4m) of type 'RB' rear hoist rope, and 36 in (0.91m) track shoes.

Item Description	Gross Weight		Transport Loads	
	lb	(kg)	#1	#2
Base Crane	68,809	31 212	1	
Add "A" Counterweight	14,000	6 350	1	
Add "B" Counterweight	10,000	4 536	1	
Add "XL" Upper Counterweight	4,630	2 100		
Add "XL" Side Frame Counterweight (2)	4,300	1 950		
Add Hydraulic Third Drum without Rope	1,053	478		
Add 3 Sheave Assembly to the Top Section	390	177		
Add 20 ft (6.10m) Angle Top Section with 4 Lifting Sheaves	2,711	1 230		1
Add 20 ft (6.10m) Angle Top Section with 2 Clam Sheaves	2,680	1 216		
Add 20 ft (6.10m) Angle Top Section with 1 Drag Sheave and 2 Lifting Sheaves	2,748	1 246		
Add 10 ft (3.05m) Angle Extension with Pins and Pendants	781	354		2
Add 20 ft (6.10m) Angle Extension with Pins and Pendants	1,335	606		1
Add 30 ft (9.14m) Angle Extension with Pins and Pendants	1,832	831		2
Add Boom Folding Equipment	500	227		
Add Tagline Winder	650	295		
Add Fairleader	1,274	578		
Add Pile Driver Lead Adapter	198	90		
Add 20 ft (6.10m) Tubular Jib with Offset Pendants	1,177	534		1
Add 10 ft (3.05m) Tubular Jib Extension	195	88		2
Add 5 ft (1.52m) Auxiliary Tip Extension	640	290		
Add Holding Rope – 0.75 in (19.05mm) x 145 ft (44.20m) Type 'DB'	151	68		
Add Closing Rope – 0.75 in (19.05mm) x 180 ft (54.86m) Type 'DB'	187	85		
Add 0.88 in (22.35mm) Front Drum Lagging	327	148		
Add Inhaul Rope – 0.88 in (22.35mm) x 95 ft (28.96m) Type 'M'	128	58		
Add Third Drum Rope – 0.63 in (16.00mm) x 385 ft (117.35m) Type 'ZB'	312	141		
Add 8.5 Ton (7.7mt) Hook Ball – Non-Swivel or Swivel	360	163		1
Add 40 Ton (36.3mt) 4 Sheave Hook Block	780	354		
Add 60 Ton (54.4mt) 4 Sheave Hook Block	1,110	503		1
Replace 36 in (0.91m) Track Shoes with 30 in (0.76m)	-3,530	-1 601		
Remove Front Hoist Rope – 0.75 in (19.05mm) x 600 ft (182.88m) Type 'DB'	-624	-283		
Remove Jib Hoist Rope – 0.75 in (19.05mm) x 500 ft (152.40m) Type 'RB'	-550	-249		
Remove 20 ft (6.10m) Angle Base Section	-1,757	-797		
Remove 50 gal (189.3L) of Fuel	-362	-164		
Approximate Total Shipping Weight	lb		92,809	12,309
	kg		42 097	5 583

Notes:

Estimated weights vary by +/- 2%. Numbers in the load columns represent quantities.

Estimated transport loads assume the load out consist of 140 ft (39.62m) of angle boom, 50 ft (15.24m) of jib, and "AB" counterweight.

Support loads were targeted at 45,000 lb (20 412kg), 8 ft 6 in (2.59m) wide, 48 ft (14.63m) long, and 13 ft 6 in (4.11m) high using a drop deck trailer. This may vary depending on state laws, empty truck/trailer weights, and style of trailer.



Working Weights

Option	Description	36" (914mm) Track Shoes		30" (762mm) Track Shoes	
		Gross Weight lb (kg)	Ground Bearing Pressure psi (kg/cm ²)	Gross Weight lb (kg)	Ground Bearing Pressure psi (kg/cm ²)
1	Base crane equipped with 40 ft (12.19m) of boom, "A" counterweight, 600 ft (182.88m) front hoist rope, 500 ft (152.40m) rear hoist rope, 77 gal (291L) of fuel, 60 Ton (54.43mt) hook block and a 200 lb (90.7kg) operator.	86,830 (39 385)	6.85 (0.48)	83,384 (37 822)	7.90 (0.56)
2	Option #1 plus "B" counterweight and 100 ft (30.48m) of boom extensions to obtain 140 ft (39.62m) of main boom.	100,778 (45 712)	7.95 (0.56)	97,332 (44 149)	9.22 (0.65)
3	Option #2 plus 50 ft (15.24m) of jib and 8.5 Ton (7.7mt) hookball – subtract 30 ft (9.14m) of boom extensions to obtain 110 + 50 ft (33.53 + 15.24m) of main boom plus jib.	101,068 (45 844)	7.98 (0.56)	97,622 (44 280)	9.24 (0.65)

Notes: Ground bearing pressure is based on the total weight distributed evenly over the track contact area.
Total contact area for 30" (0.76m) track shoes is 10,560 in² (68 129 cm²). Total contact area for 36" (0.91m) track shoes is 12,672 in² (81 755 cm²).

Transport Drawings

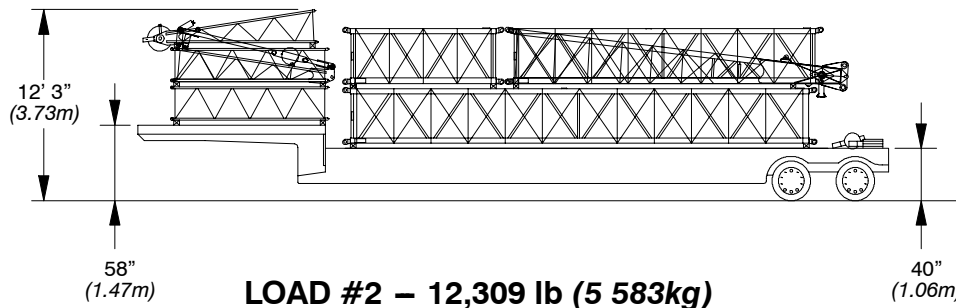
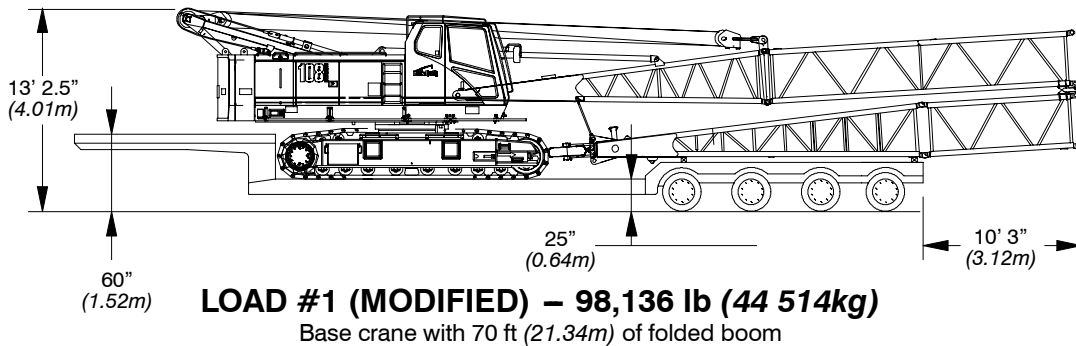
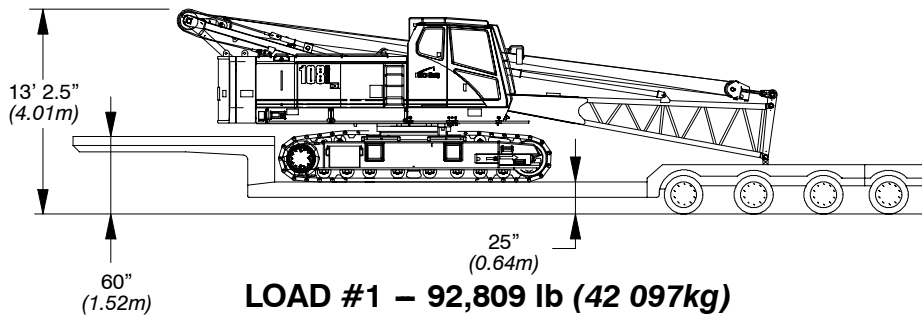

20 ft (6.10m) top section, two 10 ft (3.05m) boom extensions, 20 ft (6.10m) boom extension, two 30 ft (9.14m) boom extensions, 20 ft (6.10m) jib with offset pendants, two 10 ft (3.05m) jib extensions, 8.5 Ton (7.7mt) hook ball, and 60 Ton (54.4mt) hook block



Load Hoist Performance

Front or Rear Drum – 3/4 in (19mm) Wire Rope

Rope Layer	Maximum Line Pull		No Load Line Speed		Full Load Line Speed		Pitch Diameter		Layer		Total		
	lb	kg	ft/min	m/min	ft/min	m/min	in	mm	ft	m	ft	m	
1	32,323	14 662	264	80.5	89	27.1	16.5	419	86	26.3	86	26.3	
2	29,630	13 440	288	87.8	97	29.6	18.0	457	94	28.5	180	54.9	
3	27,350	12 406	312	95.1	105	32.0	19.5	495	101	30.7	281	85.6	
4	25,396	11 520	336	102.4	113	34.5	21.0	533	108	32.9	389	118.5	
5	23,703	10 752	360	109.7	121	37.0	22.5	571	115	35.1	504	153.5	
6	22,222	10 080	384	117.0	129	39.4	24.0	610	122	37.2	626	190.8	
7	20,914	9 487	408	124.3	137	41.9	25.5	648	129	39.4	755	230.2	
8	19,752	8 960	432	131.7	145	44.4	27.0	686	136	41.6	892	271.8	
9	Storage Layer Only							28.5	724	144	43.8	1,035	315.6

Front Drum – 7/8 in (22mm) Wire Rope

Rope Layer	Maximum Line Pull		No Load Line Speed		Full Load Line Speed		Pitch Diameter		Layer		Total	
	lb	kg	ft/min	m/min	ft/min	m/min	in	mm	ft	m	ft	m
1	26,188	11 879	330	100.6	110	33.5	20.4	517	86	26.3	86	26.3
2	24,116	10 939	358	109.2	119	36.3	22.1	562	94	28.5	180	54.9

Boom Hoist Drum – 5/8 in (16mm) Wire Rope

Rope Layer	Maximum Line Pull		No Load Line Speed		Full Load Line Speed		Pitch Diameter		Layer		Total	
	lb	kg	ft/min	m/min	ft/min	m/min	in	mm	ft	m	ft	m
1	17,080	7 747	194	59.2	172	52.5	13.2	336	48	14.8	48	14.8
2	15,605	7 078	213	64.8	188	57.4	14.5	368	53	16.1	101	30.8
3	14,364	6 515	231	70.4	205	62.4	15.7	399	57	17.3	158	48.2
4	13,306	6 036	249	76.0	221	67.3	17.0	431	61	18.6	219	66.8
5	12,393	5 622	268	81.6	237	72.3	18.2	463	65	19.9	284	86.6
6	11,598	5 261	286	87.2	253	77.2	19.5	495	69	21.1	354	107.8
7	10,898	4 943	304	92.8	270	82.2	20.7	526	74	22.4	427	130.2
8	10,278	4 662	323	98.4	286	87.2	22.0	558	78	23.7	505	153.9

Optional Third Drum – 5/8 in (16mm) Wire Rope

Rope Layer	Maximum Line Pull		No Load Line Speed		Full Load Line Speed		Pitch Diameter		Layer		Total	
	lb	kg	ft/min	m/min	ft/min	m/min	in	mm	ft	m	ft	m
1	15,041	6 822	157	48	143	43.6	11.3	286	57	17.4	57	17.4
2	13,537	6 140	175	53	159	48.5	12.5	318	64	19.5	121	36.9
3	12,307	5 582	192	59	175	53.3	13.8	349	70	21.3	192	58.5
4	11,282	5 117	210	64	191	58.0	15.0	381	76	23.1	269	82.0
5	10,414	4 724	228	69	207	63.1	16.3	413	83	25.2	352	107.3
6	9,671	4 387	245	75	223	68.0	17.5	445	89	27.1	442	134.7

Optional Fourth Drum – 3/4 in (19mm) Wire Rope

Rope Layer	Maximum Line Pull		No Load Line Speed		Full Load Line Speed		Pitch Diameter		Layer		Total	
	lb	kg	ft/min	m/min	ft/min	m/min	in	mm	ft	m	ft	m
1	22,352	10 139	189	57.7	126	38.5	16.5	419	56	17.1	56	17.1
2	20,489	9 294	207	63.0	138	42.0	18.0	457	61	18.7	117	35.8
3	18,913	8 579	224	68.2	149	45.5	19.5	495	66	20.2	184	56.0
4	17,562	7 966	241	73.5	161	49.0	21.0	533	71	21.8	255	77.8
5	16,391	7 435	258	78.7	172	52.5	22.5	571	77	23.3	332	101.1
6	15,367	6 970	275	84.0	184	56.0	24.0	610	82	24.9	413	126.0
7	14,463	6 560	293	89.2	195	59.5	25.5	648	87	26.4	500	152.4
8	13,659	6 196	310	94.5	207	63.0	27.0	686	92	28.0	592	180.4
9	12,940	5 870	327	99.7	218	66.5	28.5	724	97	29.6	689	210.0
10	12,293	5 576	344	105.0	230	70.0	30.0	762	102	31.1	791	241.1



Wire Rope Application	Diameter		Type	Max. Permissible Load		Wire Rope Descriptions
	in	mm		lb	kg	
Boom Hoist	5/8	16	W	11,700	5 307	6 x 26 (6 x 19 Class) – Extra Improved Plow Steel – Preformed – Right Lay – Alternate Lay – I.W.R.C.
Front Hoist	3/4	19	DB	16,800	7 620	6 X 26 (6 X 19 Class), Warrington Seale, E.I.P.S., Preformed, Right Regular Lay, I.W.R.C.
Rear Hoist	3/4	19	RB	12,900	5 851	19 X 19 Rotation Resistant Compacted Strand – High Strength – Preformed, Right Regular Lay
Third Drum	5/8	16	ZB	11,080	5 026	36 x 7 – Non-rotating – Extra Improved Plow Steel – Right Lay – Regular Lay
Clamshell (Holding)	3/4	19	DB	16,800	7 620	6 X 26 (6 X 19 Class), Warrington Seale, E.I.P.S., Preformed, Right Regular Lay, I.W.R.C.
Clamshell (Closing)	3/4	19	DB	16,800	7 620	6 X 26 (6 X 19 Class), Warrington Seale, E.I.P.S., Preformed, Right Regular Lay, I.W.R.C.
Dragline (Hoist)	3/4	19	DB	16,800	7 620	6 X 26 (6 X 19 Class), Warrington Seale, E.I.P.S., Preformed, Right Regular Lay, I.W.R.C.
Dragline (Inhaul)	7/8	22	M	22,740	10 315	6 X 25 (6 X 19 Class), Filler Wire, E.I.P.S., Preformed, I.W.R.C., Right Lay, Lang Lay

Working Areas

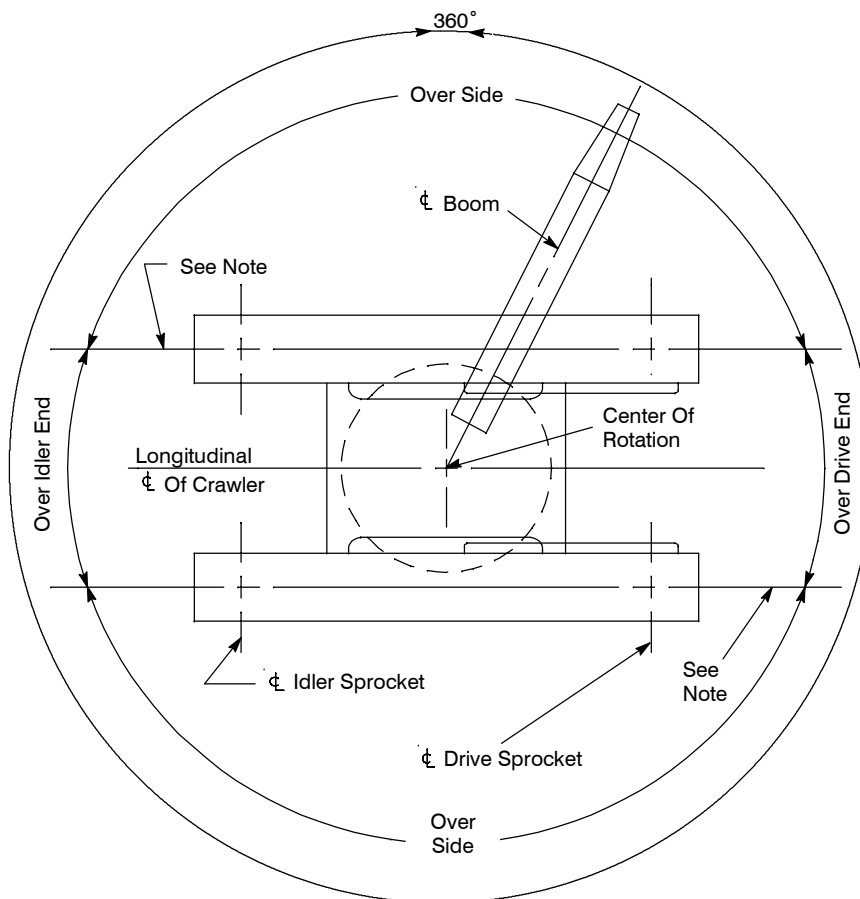

Note: These Lines Determine The Limiting Position Of Any Load For Operation Within Working Areas Indicated.



Attachments

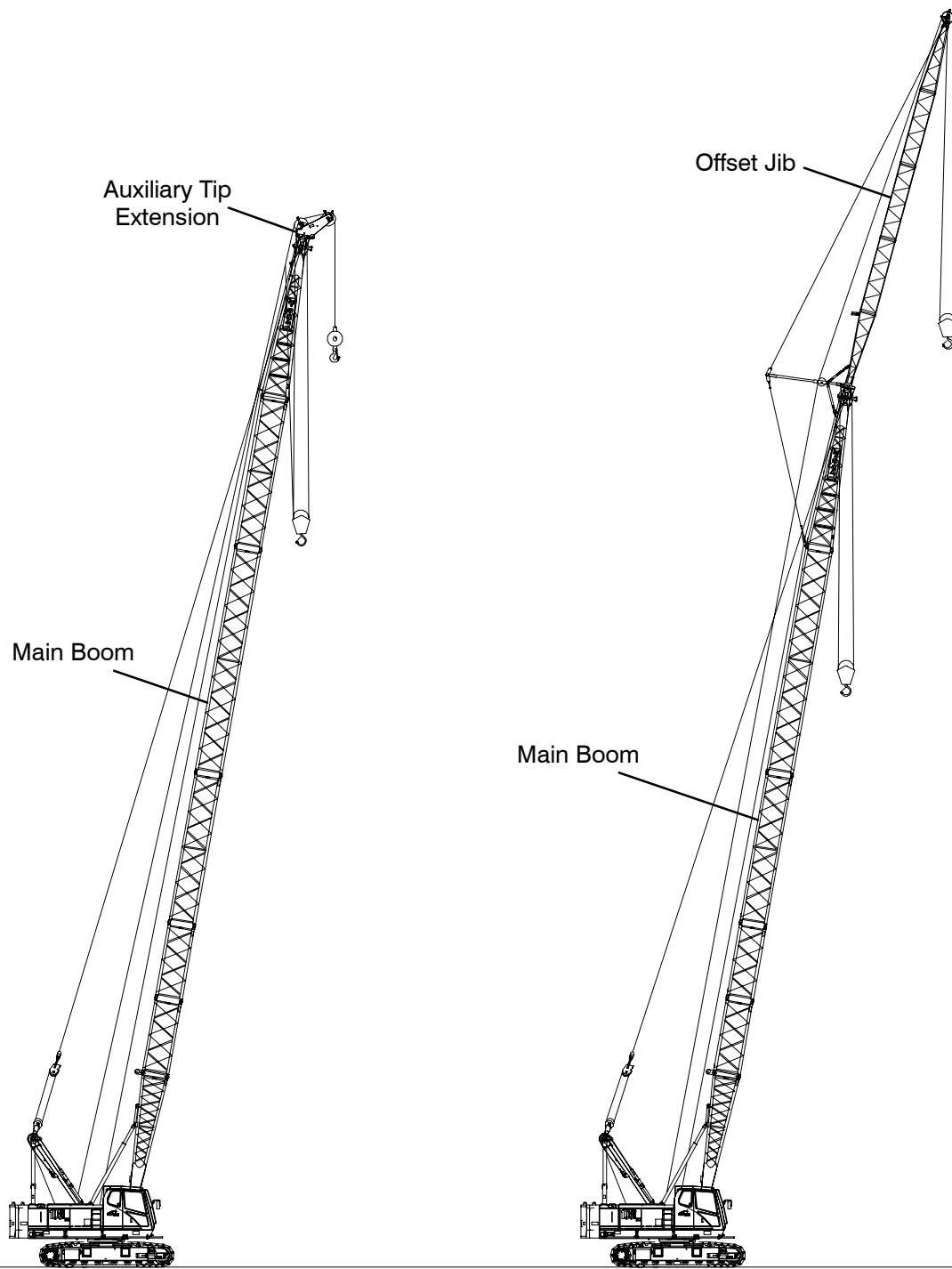

40–140 ft (12.20–42.67m)
Main Boom With 5 ft (1.5m)
Tip Extension

40–110 ft (12.20–33.53m)
Main Boom With 20–50 ft
(6.10–15.24m) Jib



Main Boom Make-up

Boom Length ft (m)		Base	Boom Extensions ft (m)				Top
ft	m	20 (6.14)	10 (3.05)	20 (6.14)	30 (9.10)	20 (6.14)	
40	12.20	1				1	
50	15.24	1	1			1	
60	18.29	1		1		1	
70	21.34	1			1	1	
80	24.38	1	1		1	1	
90	27.43	1		1	1	1	
100	30.48	1			2	1	
110	33.53	1	1		2	1	
120	36.58	1		1	2	1	
130	39.62	1	1	1	2	1	
140	42.67	1	2	1	2	1	

Notes:

- Capacities shown are in kips/metric tons (1 kip = 1,000 lb / 1 kip = 0.45 metric ton) and are not more than 75% of the tipping loads with the crane standing level on firm supporting surface. A deduction must be made from these capacities for weight of hook block, hook ball, sling, grapple, load weighing device, etc. When using main hook while jib or tip extension is attached, reduce capacities by values shown in Crane Rating Manual. See Operator's Manual for all limitations when raising or lowering attachment.
- The capacities in the shaded areas are based on structural strength. The capacities in the non-shaded areas are based on stability ratings.
- For recommended reeving, parts of line, wire rope type, and wire rope inspection, see Wire Rope Capacity Chart, Operator's Manual, and Parts Manual.
- Load ratings are based on freely suspended loads and make no allowances for such factors as the effect of the wind, ground conditions, and operating speeds. The operator shall therefore reduce load ratings in order to take these conditions into account. Refer to the Crane Rating Manual for Wind Speed Restrictions.
- The least stable rated condition is over the side.
- Booms must be erected and lowered over the end for maximum stability.
- Main boom length must not exceed 140 ft (42.67m).
- Do not operate at radii and boom lengths where the Crane Rating Manual lists no capacity. Do not use longer booms or jibs than those listed in the Crane Rating Manual. Any of the above can cause a tipping condition, or boom and jib failure.
- These capacities are in compliance with ASME/ANSI B30.5 at date of manufacture.
- These capacities apply only to the crane as originally manufactured and normally equipped by Link-Belt Construction Equipment Company.
- These capacities are for "AB" [34,000 lb (15 422kg)] and "AB" + "XL" [38,630 lb (17 522kg) + 8,600 lb (3 900kg)] counterweight configurations as noted.

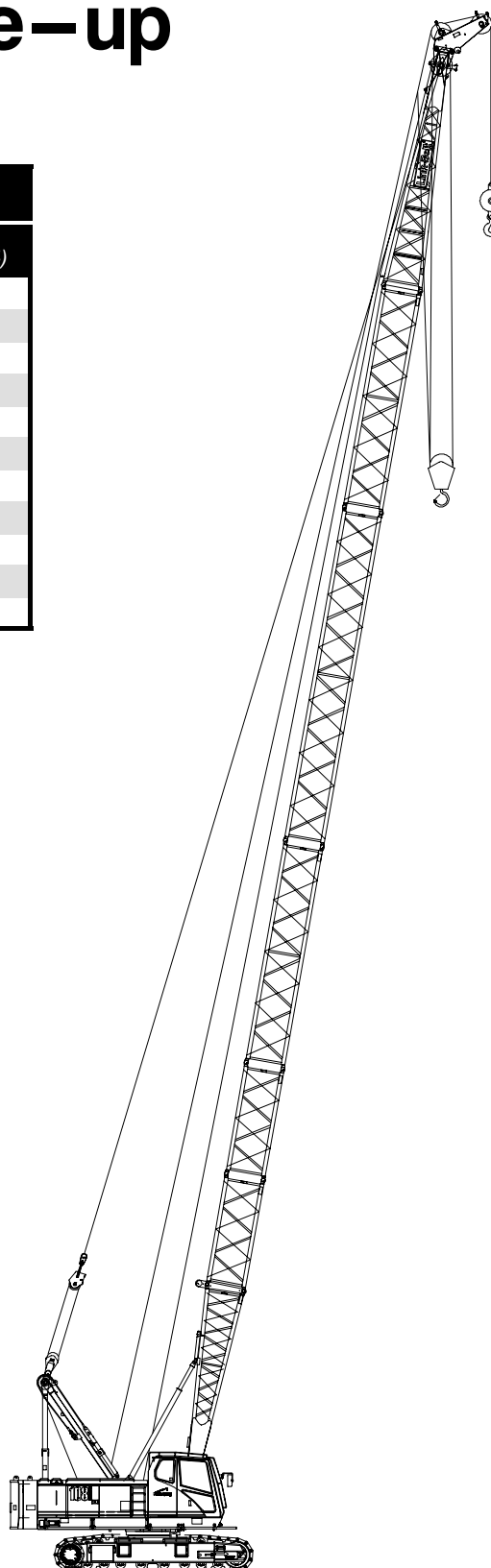



Duty Cycle Working Range Diagrams

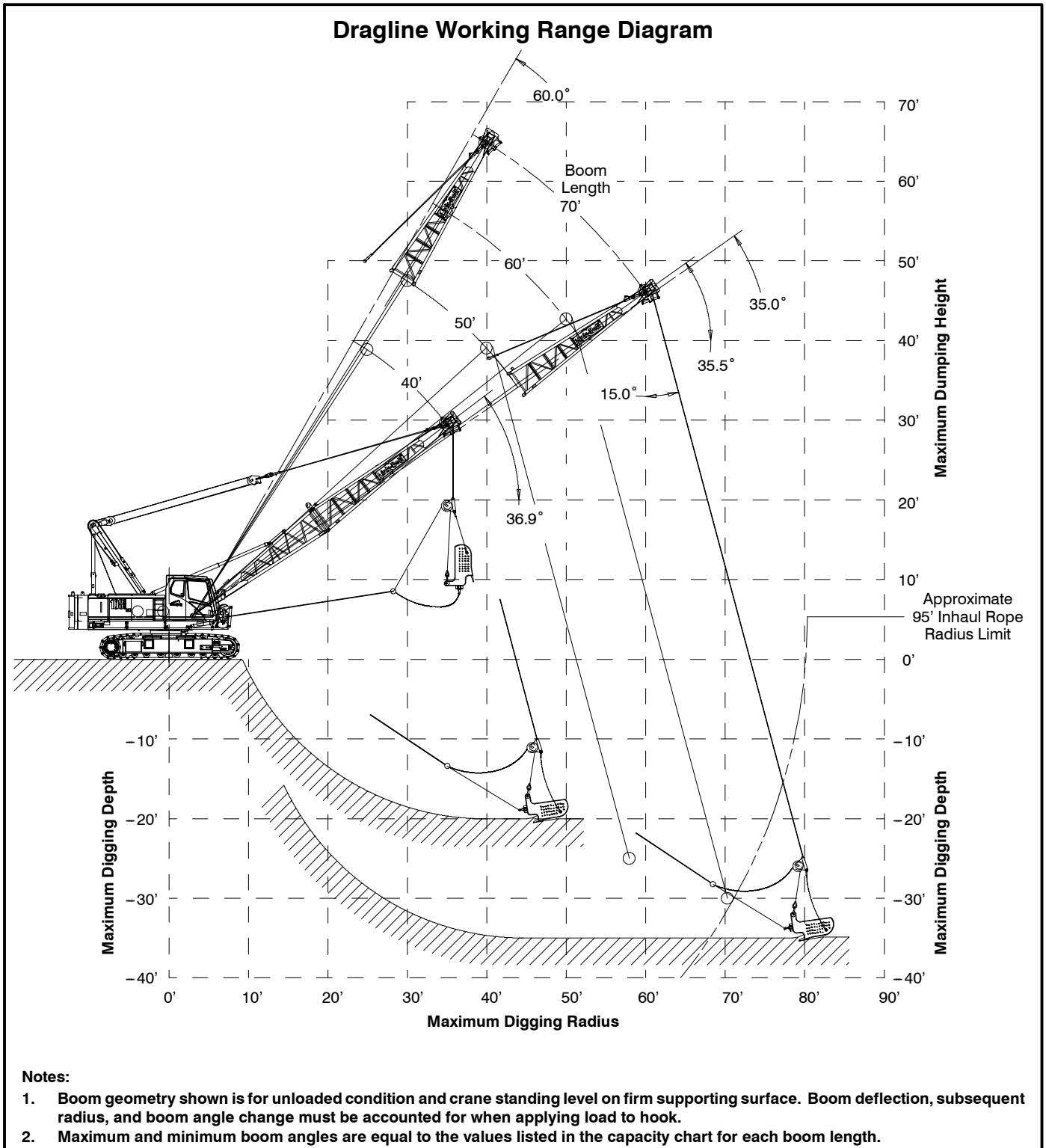



Clamshell Working Range Diagram

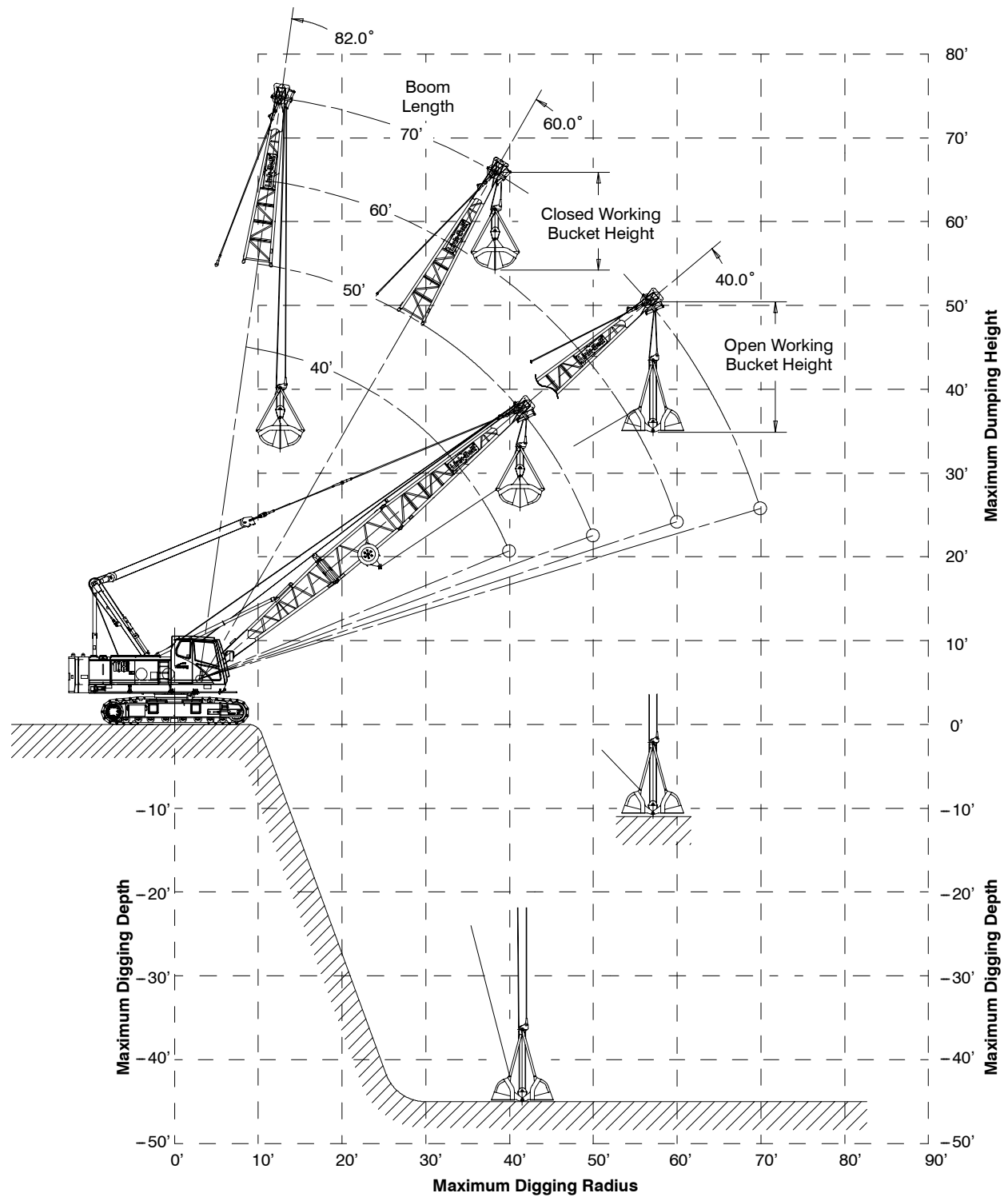

Notes:

1. Boom geometry shown is for unloaded condition and crane standing level on firm supporting surface. Boom deflection, subsequent radius, and boom angle change must be accounted for when applying load to hook.
2. Maximum and minimum boom angles are equal to the values listed in the capacity chart for each boom length.



Duty Cycle Load Charts

Duty Cycle Lift Capacity Chart – 360° Rotation – AB Counterweight – Side Frames Extended

[All capacities are listed in kips (mt)]

Load Radius ft (m)	Boom Length ft (m)							
	40 (12.2)		50 (15.2)		60 (18.3)		70 (21.3)	
	Dragline	Clamshell/ Magnet	Dragline	Clamshell/ Magnet	Dragline	Clamshell/ Magnet	Dragline	Clamshell/ Magnet
9 (2.7)	16.8 (7.6)	16.8 (7.6)						
10 (3.1)	16.8 (7.6)	16.8 (7.6)	16.8 (7.6)	16.8 (7.6)				
11 (3.4)	16.8 (7.6)	16.8 (7.6)	16.8 (7.6)	16.8 (7.6)				
12 (3.7)	16.8 (7.6)	16.8 (7.6)	16.8 (7.6)	16.8 (7.6)	16.8 (7.6)	16.8 (7.6)		
13 (4.0)	16.8 (7.6)	16.8 (7.6)	16.8 (7.6)	16.8 (7.6)	16.8 (7.6)	16.8 (7.6)	16.8 (7.6)	16.8 (7.6)
14 (4.3)	16.8 (7.6)	16.8 (7.6)	16.8 (7.6)	16.8 (7.6)	16.8 (7.6)	16.8 (7.6)	16.8 (7.6)	16.8 (7.6)
15 (4.6)	16.8 (7.6)	16.8 (7.6)	16.8 (7.6)	16.8 (7.6)	16.8 (7.6)	16.8 (7.6)	16.8 (7.6)	16.8 (7.6)
16 (4.9)	16.8 (7.6)	16.8 (7.6)	16.8 (7.6)	16.8 (7.6)	16.8 (7.6)	16.8 (7.6)	16.8 (7.6)	16.8 (7.6)
17 (5.2)	16.8 (7.6)	16.8 (7.6)	16.8 (7.6)	16.8 (7.6)	16.8 (7.6)	16.8 (7.6)	16.8 (7.6)	16.8 (7.6)
18 (5.5)	16.8 (7.6)	16.8 (7.6)	16.8 (7.6)	16.8 (7.6)	16.8 (7.6)	16.8 (7.6)	16.8 (7.6)	16.8 (7.6)
19 (5.8)	16.8 (7.6)	16.8 (7.6)	16.8 (7.6)	16.8 (7.6)	16.8 (7.6)	16.8 (7.6)	16.8 (7.6)	16.8 (7.6)
20 (6.1)	16.8 (7.6)	16.8 (7.6)	16.8 (7.6)	16.8 (7.6)	16.8 (7.6)	16.8 (7.6)	16.8 (7.6)	16.8 (7.6)
25 (7.6)	16.8 (7.6)	16.8 (7.6)	16.8 (7.6)	16.8 (7.6)	16.8 (7.6)	16.8 (7.6)	16.8 (7.6)	16.8 (7.6)
30 (9.1)	16.8 (7.6)	16.8 (7.6)	16.8 (7.6)	16.8 (7.6)	16.8 (7.6)	16.8 (7.6)	16.8 (7.6)	16.8 (7.6)
35 (10.7)	16.8 (7.6)	16.8 (7.6)	16.8 (7.6)	16.8 (7.6)	16.8 (7.6)	16.8 (7.6)	16.8 (7.6)	16.8 (7.6)
40 (12.2)	16.1 (7.3)	14.4 (6.5)	15.9 (7.2)	14.3 (6.4)	15.7 (7.1)	14.1 (6.4)	15.5 (7.0)	13.9 (6.3)
50 (15.2)			11.6 (5.2)	10.4 (4.7)	11.4 (5.1)	10.2 (4.6)	11.2 (5.0)	10.0 (4.5)
60 (18.3)					8.7 (3.9)	7.8 (3.5)	8.5 (3.8)	7.6 (3.4)
70 (21.3)							6.7 (3.0)	6.0 (2.7)

This material is supplied for reference use only. Operator must refer to in-cab Crane Rating Manual and Operator's Manual to determine allowable crane lifting capacities and assembly and operating procedures.



Main Boom Working Range Diagram

40' To 140' Open Throat Boom

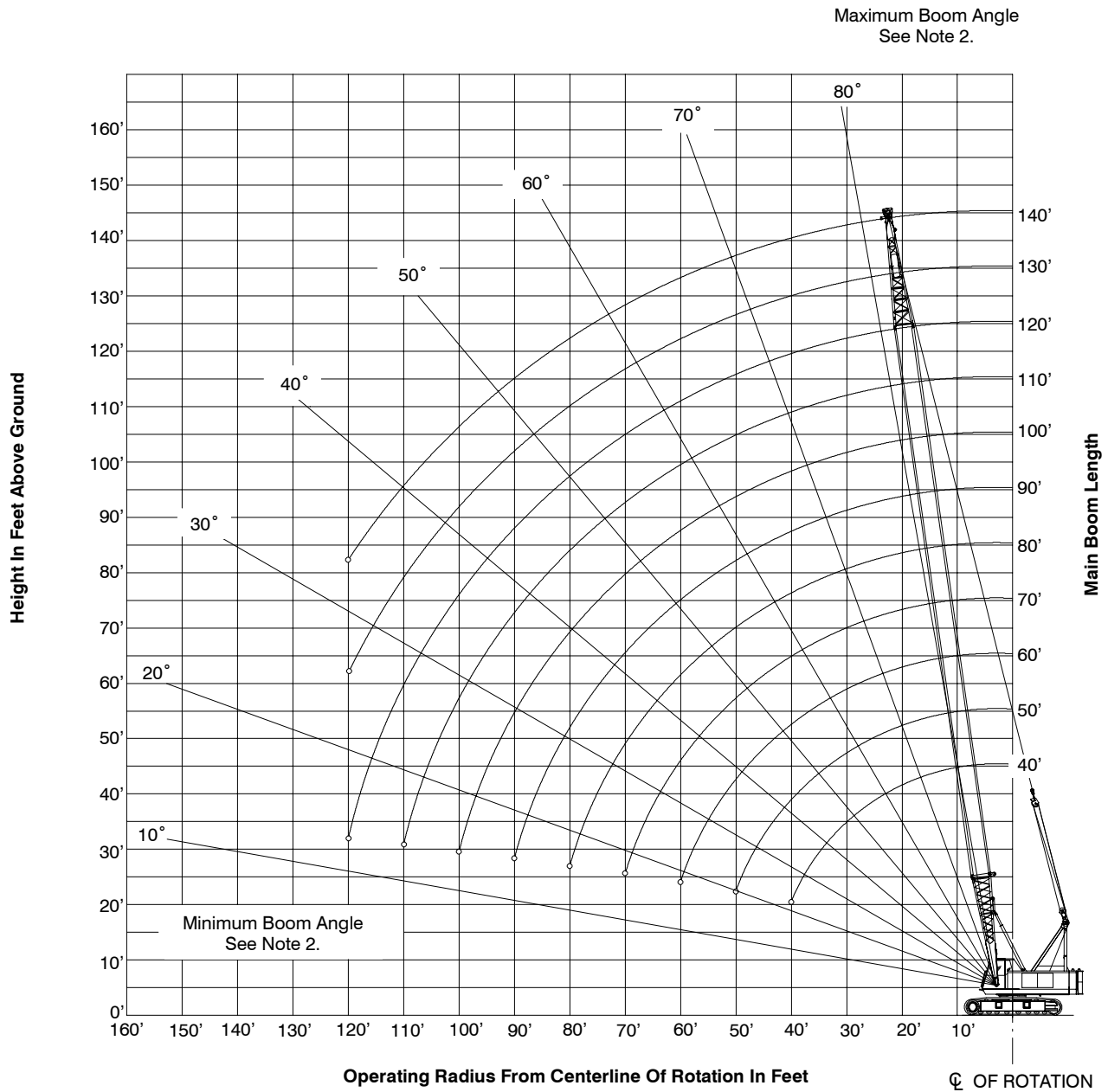

Notes:

1. Boom geometry shown is for unloaded condition and crane standing level on firm supporting surface. Boom deflection, subsequent radius, and boom angle change must be accounted for when applying load to hook.
2. Maximum and minimum boom angles are equal to the values listed in the capacity chart for each boom length.



Main Boom Load Charts

Main Boom Lift Capacity Chart – 360° Rotation – AB Counterweight – Side Frames Extended

[All capacities are listed in kips (mt)]

Load Radius ft (m)	Boom Length ft (m)										
	40 (12.2)	50 (15.2)	60 (18.3)	70 (21.3)	80 (24.4)	90 (27.4)	100 (30.5)	110 (33.5)	120 (36.6)	130 (39.6)	140 (42.7)
9 (2.7)	100.0 (45.3)										
10 (3.1)	100.0 (45.3)	98.4 (44.6)									
11 (3.4)	100.0 (45.3)	96.0 (43.5)									
12 (3.7)	94.2 (42.7)	93.6 (42.4)	85.0 (38.5)								
13 (4.0)	85.9 (38.9)	85.9 (38.9)	81.8 (37.1)	74.0 (33.5)							
14 (4.3)	75.2 (34.1)	75.1 (34.0)	75.0 (34.0)	72.2 (32.7)							
15 (4.6)	66.8 (30.3)	66.7 (30.2)	66.6 (30.2)	66.5 (30.1)	63.8 (28.9)						
16 (4.9)	60.0 (27.2)	59.9 (27.1)	59.8 (27.1)	59.7 (27.0)	59.6 (27.0)	57.4 (26.0)					
17 (5.2)	54.5 (24.7)	54.4 (24.6)	54.2 (24.5)	54.1 (24.5)	54.0 (24.5)	53.8 (24.4)	51.7 (23.4)				
18 (5.5)	49.8 (22.5)	49.7 (22.5)	49.5 (22.4)	49.4 (22.4)	49.3 (22.3)	49.1 (22.2)	49.0 (22.2)				
19 (5.8)	45.8 (20.7)	45.7 (20.7)	45.6 (20.6)	45.4 (20.6)	45.3 (20.5)	45.1 (20.4)	45.0 (20.4)	44.8 (20.3)			
20 (6.1)	42.4 (19.2)	42.3 (19.1)	42.1 (19.1)	42.0 (19.0)	41.9 (19.0)	41.7 (18.9)	41.5 (18.8)	41.4 (18.7)	41.1 (18.6)		
25 (7.6)	30.7 (13.9)	30.6 (13.8)	30.4 (13.7)	30.2 (13.7)	30.1 (13.6)	29.9 (13.5)	29.7 (13.4)	29.5 (13.3)	29.3 (13.3)	29.1 (13.2)	29.0 (13.1)
30 (9.1)	23.8 (10.8)	23.7 (10.7)	23.5 (10.6)	23.3 (10.5)	23.1 (10.4)	22.9 (10.3)	22.8 (10.3)	22.6 (10.2)	22.4 (10.1)	22.2 (10.0)	22.0 (9.9)
35 (10.7)	19.3 (8.7)	19.1 (8.6)	18.9 (8.5)	18.8 (8.5)	18.6 (8.4)	18.4 (8.3)	18.2 (8.2)	18.0 (8.1)	17.8 (8.0)	17.6 (7.9)	17.4 (7.9)
40 (12.2)	16.1 (7.3)	15.9 (7.2)	15.7 (7.1)	15.5 (7.0)	15.3 (6.9)	15.1 (6.8)	14.9 (6.7)	14.7 (6.6)	14.5 (6.5)	14.3 (6.4)	14.1 (6.4)
50 (15.2)		11.6 (5.2)	11.4 (5.1)	11.2 (5.0)	11.1 (5.0)	10.8 (4.9)	10.6 (4.8)	10.4 (4.7)	10.2 (4.6)	10.0 (4.5)	9.8 (4.4)
60 (18.3)			8.7 (3.9)	8.5 (3.8)	8.3 (3.7)	8.1 (3.6)	7.9 (3.5)	7.7 (3.5)	7.5 (3.4)	7.3 (3.3)	7.0 (3.1)
70 (21.3)				6.7 (3.0)	6.5 (2.9)	6.3 (2.8)	6.1 (2.7)	5.8 (2.6)	5.6 (2.5)	5.4 (2.4)	5.2 (2.3)
80 (24.4)					5.1 (2.3)	4.9 (2.2)	4.7 (2.1)	4.5 (2.0)	4.2 (1.9)	4.0 (1.8)	3.8 (1.7)
90 (27.4)						3.8 (1.7)	3.6 (1.6)	3.4 (1.5)	3.2 (1.4)	3.0 (1.3)	2.7 (1.2)
100 (30.5)							2.8 (1.2)	2.6 (1.1)	2.4 (1.0)	2.1 (0.9)	1.9 (0.8)
110 (33.5)								1.9 (0.8)	1.7 (0.7)		

This material is supplied for reference use only. Operator must refer to in-cab Crane Rating Manual and Operator's Manual to determine allowable crane lifting capacities and assembly and operating procedures.



Main Boom Lift Capacity Chart – 360° Rotation – AB+XL Counterweight – Side Frames Extended

[All capacities are listed in kips (mt)]

Load Radius ft (m)	Boom Length ft (m)										
	40 (12.2)	50 (15.2)	60 (18.3)	70 (21.3)	80 (24.4)	90 (27.4)	100 (30.5)	110 (33.5)	120 (36.6)	130 (39.6)	140 (42.7)
9 (2.7)	110.0 (49.9)										
10 (3.1)	110.0 (49.9)										
11 (3.4)	103.8 (47.1)	96.0 (43.6)									
12 (3.7)	95.1 (43.1)	93.6 (42.5)	85.0 (38.6)								
13 (4.0)	87.8 (39.8)	87.8 (39.8)	81.8 (37.1)	74.0 (33.6)							
14 (4.3)	81.5 (37.0)	81.5 (37.0)	79.7 (36.2)	72.2 (32.8)							
15 (4.6)	76.1 (34.5)	76.1 (34.5)	76.1 (34.5)	70.8 (32.1)	63.8 (28.9)						
16 (4.9)	69.9 (31.7)	69.8 (31.7)	69.7 (31.6)	69.1 (31.4)	62.2 (28.2)	57.4 (26.0)					
17 (5.2)	63.5 (28.8)	63.4 (28.8)	63.2 (28.7)	63.1 (28.6)	61.4 (27.9)	56.3 (25.5)	51.7 (23.5)				
18 (5.5)	58.1 (26.4)	58.0 (26.3)	57.8 (26.2)	57.7 (26.2)	57.6 (26.1)	55.2 (25.0)	51.0 (23.1)				
19 (5.8)	53.5 (24.3)	53.4 (24.2)	53.2 (24.1)	53.1 (24.1)	52.9 (24.0)	52.8 (24.0)	48.8 (22.1)	45.1 (20.5)			
20 (6.1)	49.6 (22.5)	49.4 (22.4)	49.3 (22.4)	49.1 (22.3)	49.0 (22.2)	48.8 (22.1)	48.2 (21.9)	44.5 (20.2)	41.1 (18.6)		
25 (7.6)	36.0 (16.3)	35.9 (16.3)	35.7 (16.2)	35.5 (16.1)	35.3 (16.0)	35.2 (16.0)	35.0 (15.9)	34.8 (15.8)	34.6 (15.7)	34.4 (15.6)	31.4 (14.2)
30 (9.1)	28.0 (12.7)	27.9 (12.7)	27.7 (12.6)	27.5 (12.5)	27.3 (12.4)	27.1 (12.3)	26.9 (12.2)	26.7 (12.1)	26.5 (12.0)	26.3 (11.9)	26.1 (11.8)
35 (10.7)	22.8 (10.3)	22.6 (10.3)	22.4 (10.2)	22.2 (10.1)	22.0 (10.0)	21.8 (9.9)	21.6 (9.8)	21.4 (9.7)	21.2 (9.6)	21.0 (9.5)	20.8 (9.4)
40 (12.2)	19.0 (8.6)	18.9 (8.6)	18.7 (8.5)	18.5 (8.4)	18.3 (8.3)	18.1 (8.2)	17.9 (8.1)	17.7 (8.0)	17.5 (7.9)	17.3 (7.8)	17.1 (7.8)
50 (15.2)		13.9 (6.3)	13.7 (6.2)	13.5 (6.1)	13.3 (6.0)	13.1 (5.9)	12.9 (5.9)	12.7 (5.8)	12.5 (5.7)	12.3 (5.6)	12.1 (5.5)
60 (18.3)			10.6 (4.8)	10.4 (4.7)	10.2 (4.6)	10.0 (4.5)	9.8 (4.4)	9.6 (4.4)	9.4 (4.3)	9.1 (4.1)	8.9 (4.0)
70 (21.3)				8.2 (3.7)	8.1 (3.7)	7.8 (3.5)	7.6 (3.4)	7.4 (3.4)	7.2 (3.3)	7.0 (3.2)	6.7 (3.0)
80 (24.4)					6.5 (2.9)	6.3 (2.9)	6.0 (2.7)	5.8 (2.6)	5.6 (2.5)	5.4 (2.5)	5.2 (2.4)
90 (27.4)						5.0 (2.3)	4.8 (2.2)	4.6 (2.1)	4.4 (2.0)	4.2 (1.9)	3.9 (1.8)
100 (30.5)							3.9 (1.8)	3.7 (1.7)	3.4 (1.5)	3.2 (1.5)	3.0 (1.4)
110 (33.5)								2.9 (1.3)	2.7 (1.2)	2.4 (1.1)	2.2 (1.0)
120 (36.65)									2.0 (0.9)	1.8 (0.8)	1.6 (0.7)

This material is supplied for reference use only. Operator must refer to in-cab Crane Rating Manual and Operator's Manual to determine allowable crane lifting capacities and assembly and operating procedures.



Jib Attachment Make-up

Jib Length ft (m)	Base	Jib Extensions	Top
	10 ft (3.05m)	10 ft (3.05m)	10 ft (3.05m)
20 (6.10)	1		1
30 (9.15)	1	1	1
40 (12.19)	1	2	1
50 (15.24)	1	3	1

Notes:

- Capacities shown are in kips/metric tons (1 kip = 1,000 lb / 1 kip = 0.45 metric ton) and are not more than 75% of the tipping loads with the crane standing level on a firm supporting surface.
- A deduction must be made from these capacities for the weight of the main boom hook block or hook ball, jib hook block or hook ball, slings, grapples, load weighing devices, etc. When using main hook while jib is attached, reduce capacities by values shown in Crane Rating Manual. See Operator's Manual for all limitations when raising or lowering attachment.
- The capacities in the shaded areas are based on structural strength. The capacities in the non-shaded areas are based on stability ratings.
- Load ratings are based on freely suspended loads and make no allowances for such factors as the effect of the wind, ground conditions, and operating speeds. The operator shall therefore reduce load ratings in order to take these conditions into account. Refer to the Crane Rating Manual for Wind Speed Restrictions.
- These capacities are for "AB" [34,000 lb (15 422kg)] and "AB" + "XL" [38,630 lb (17 522kg) + 8,600 lb (3 900kg)].
- These capacities are for 360° working areas.
- These capacities are for 20–50 ft (6.10–15.24m) jib lengths only.
- The jib cannot be used on boom lengths over 110 ft (33.52m).
- The least stable rated condition is over the side.
- These capacities are in compliance with ASME/ANSI B30.5 at date of manufacture.
- These capacities apply only to the crane as originally manufactured and normally equipped by Link-Belt Construction Equipment Company.

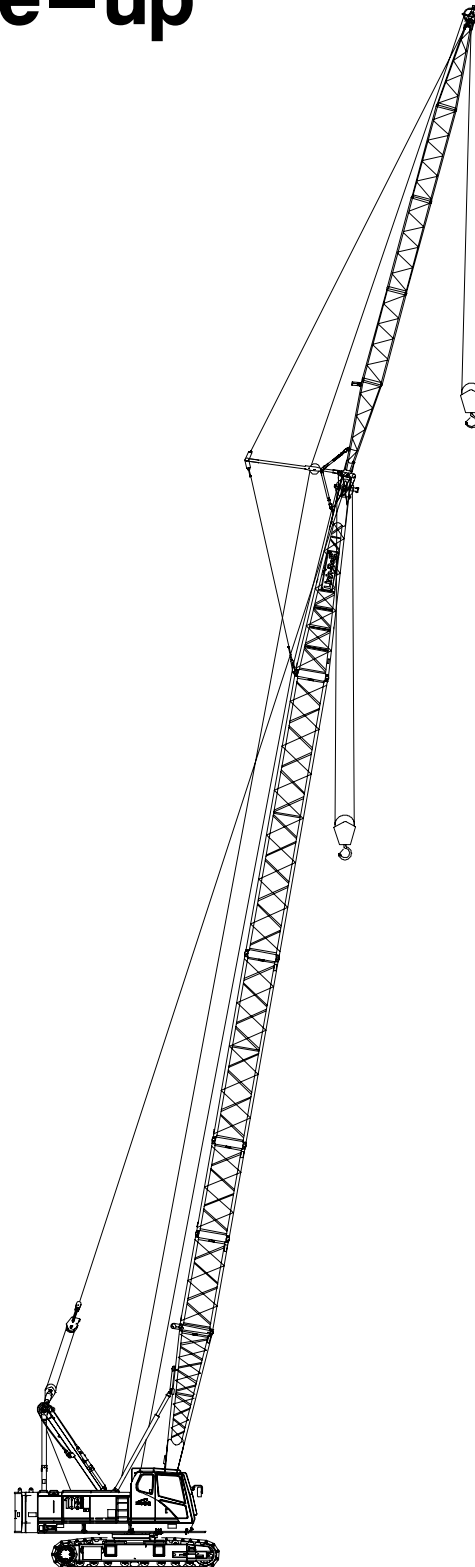



Jib Attachment Working Range Diagram

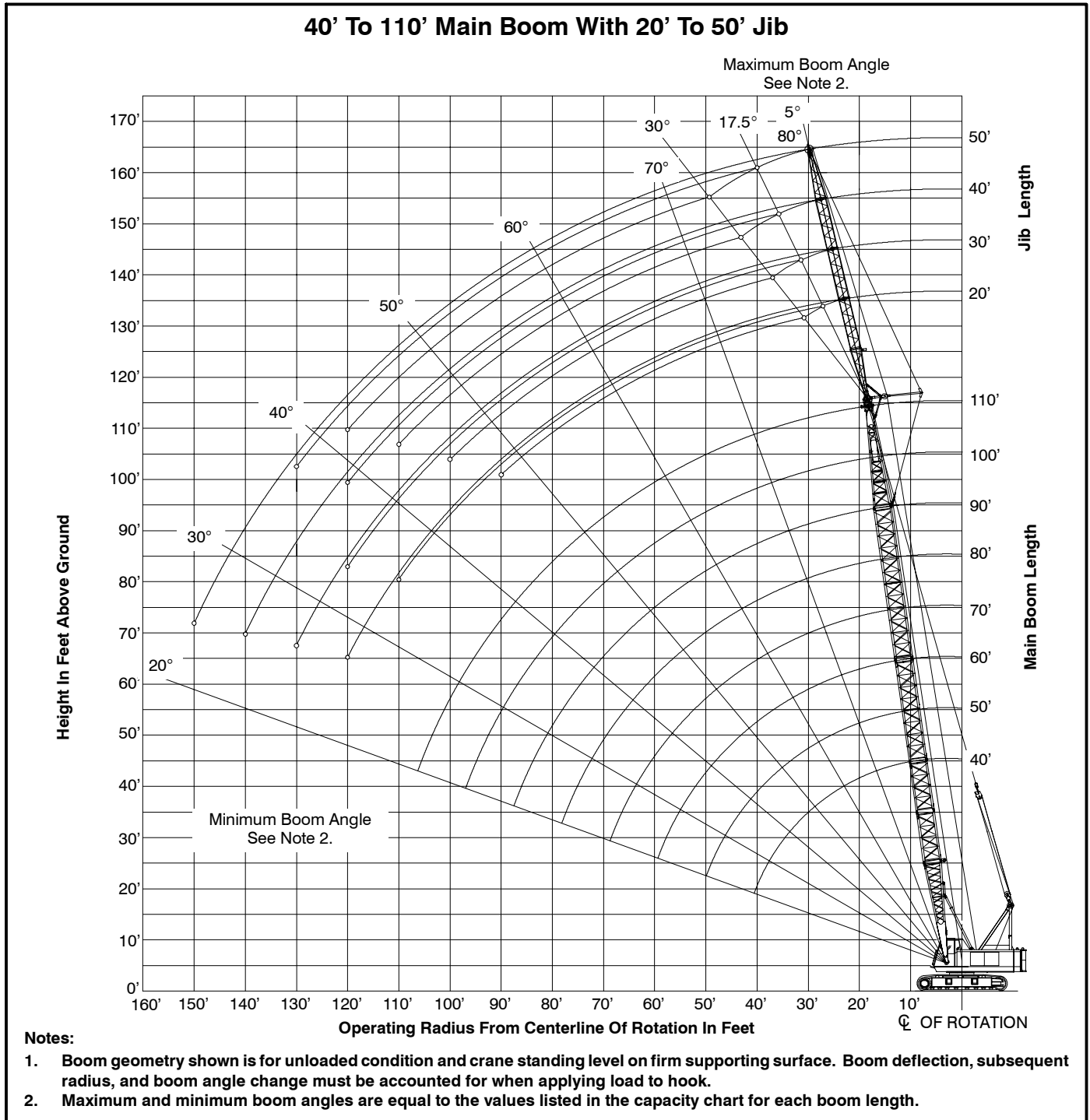



Jib Attachment Load Charts

40 ft (12.2m) Main Boom Length – 360° Rotation – AB or AB+XL Counterweight [All capacities are listed in kips (mt)]														
5° Offset					17.5° Offset					30° Offset				
Load Radius ft (m)	Jib Length ft (m)				Load Radius ft (m)	Jib Length ft (m)				Load Radius ft (m)	Jib Length ft (m)			
	20 (6.1)	30 (9.1)	40 (12.2)	50 (15.2)		20 (6.1)	30 (9.1)	40 (12.2)	50 (15.2)		20 (6.1)	30 (9.1)	40 (12.2)	50 (15.2)
16 (4.9)	20.0 (9.0)				16 (4.9)					16 (4.9)				
17 (5.2)	20.0 (9.0)				17 (5.2)					17 (5.2)				
18 (5.5)	20.0 (9.0)	20.0 (9.0)			18 (5.5)					18 (5.5)				
19 (5.8)	20.0 (9.0)	20.0 (9.0)			19 (5.8)					19 (5.8)				
20 (6.1)	20.0 (9.0)	20.0 (9.0)			20 (6.1)	20.0 (9.0)				20 (6.1)				
25 (7.6)	20.0 (9.0)	20.0 (9.0)	20.0 (9.0)	19.0 (8.6)	25 (7.6)	20.0 (9.0)	19.5 (8.8)			25 (7.6)	14.4 (6.5)			
30 (9.1)	20.0 (9.0)	20.0 (9.0)	20.0 (9.0)	17.9 (8.1)	30 (9.1)	19.8 (8.9)	17.2 (7.8)	15.5 (7.0)		30 (9.1)	13.1 (5.9)	11.1 (5.0)		
35 (10.7)	19.8 (8.9)	20.0 (9.0)	18.3 (8.3)	16.0 (7.2)	35 (10.7)	17.7 (8.0)	15.3 (6.9)	13.8 (6.2)	12.7 (5.7)	35 (10.7)	12.1 (5.4)	10.2 (4.6)		
40 (12.2)	16.5 (7.4)	16.7 (7.5)	16.8 (7.6)	15.0 (6.8)	40 (12.2)	16.0 (7.2)	13.8 (6.2)	12.5 (5.6)	11.4 (5.1)	40 (12.2)	11.3 (5.1)	9.5 (4.3)	8.3 (3.7)	
50 (15.2)	12.2 (5.5)	12.4 (5.6)	12.5 (5.6)	12.4 (5.6)	50 (15.2)	12.3 (5.5)	11.7 (5.3)	10.4 (4.7)	9.5 (4.3)	50 (15.2)		8.3 (3.7)	7.2 (3.2)	6.4 (2.9)
60 (18.3)		9.6 (4.3)	9.7 (4.4)	9.8 (4.4)	60 (18.3)		9.7 (4.4)	9.0 (4.0)	8.2 (3.7)	60 (18.3)			6.4 (2.9)	5.6 (2.5)
70 (21.3)			7.8 (3.5)	7.9 (3.5)	70 (21.3)			8.0 (3.6)	7.2 (3.2)	70 (21.3)				5.0 (2.2)
80 (24.4)				6.5 (2.9)	80 (24.4)				6.4 (2.9)					

This material is supplied for reference use only. Operator must refer to in-cab Crane Rating Manual and Operator's Manual to determine allowable crane lifting capacities and assembly and operating procedures.



50 ft (15.2m) Main Boom Length – 360° Rotation – AB or AB+XL Counterweight [All capacities are listed in kips (mt)]														
5° Offset					17.5° Offset					30° Offset				
Load Radius ft (m)	Jib Length ft (m)				Load Radius ft (m)	Jib Length ft (m)				Load Radius ft (m)	Jib Length ft (m)			
	20 (6.1)	30 (9.1)	40 (12.2)	50 (15.2)		20 (6.1)	30 (9.1)	40 (12.2)	50 (15.2)		20 (6.1)	30 (9.1)	40 (12.2)	50 (15.2)
18 (5.5)	20.0 (9.0)				18 (5.5)					18 (5.5)				
19 (5.8)	20.0 (9.0)				19 (5.8)					19 (5.8)				
20 (6.1)	20.0 (9.0)	20.0 (9.0)			20 (6.1)					20 (6.1)				
25 (7.6)	20.0 (9.0)	20.0 (9.0)	20.0 (9.0)	19.2 (8.7)	25 (7.6)	20.0 (9.0)				25 (7.6)	14.9 (6.7)			
30 (9.1)	20.0 (9.0)	20.0 (9.0)	19.7 (8.9)	17.4 (7.9)	30 (9.1)	20.0 (9.0)	18.1 (8.2)			30 (9.1)	13.7 (6.2)			
35 (10.7)	19.5 (8.8)	19.7 (8.9)	17.5 (7.9)	16.0 (7.2)	35 (10.7)	19.2 (8.7)	16.3 (7.4)	14.5 (6.5)	13.1 (5.9)	35 (10.7)	12.7 (5.7)	10.6 (4.8)		
40 (12.2)	16.3 (7.4)	16.5 (7.4)	16.3 (7.4)	14.4 (6.5)	40 (12.2)	16.5 (7.4)	14.8 (6.7)	13.2 (5.9)	11.9 (5.4)	40 (12.2)	11.9 (5.4)	9.9 (4.5)	8.5 (3.8)	
50 (15.2)	11.9 (5.4)	12.1 (5.4)	12.3 (5.5)	11.9 (5.4)	50 (15.2)	12.1 (5.4)	12.4 (5.6)	11.1 (5.0)	10.1 (4.5)	50 (15.2)	10.7 (4.8)	8.7 (3.9)	7.5 (3.4)	6.6 (3.0)
60 (18.3)	9.2 (4.1)	9.4 (4.2)	9.5 (4.3)	9.6 (4.3)	60 (18.3)	9.3 (4.2)	9.5 (4.3)	9.7 (4.4)	8.7 (3.9)	60 (18.3)		7.9 (3.5)	6.7 (3.0)	5.8 (2.6)
70 (21.3)		7.5 (3.4)	7.6 (3.4)	7.7 (3.5)	70 (21.3)		7.6 (3.4)	7.8 (3.5)	7.7 (3.5)	70 (21.3)			6.1 (2.7)	5.3 (2.4)
80 (24.4)			6.2 (2.8)	6.3 (2.8)	80 (24.4)			6.3 (2.8)	6.4 (2.9)	80 (24.4)				4.8 (2.1)
90 (27.4)				5.2 (2.3)	90 (27.4)				5.3 (2.4)					

This material is supplied for reference use only. Operator must refer to in-cab Crane Rating Manual and Operator's Manual to determine allowable crane lifting capacities and assembly and operating procedures.



60 ft (18.3m) Main Boom Length – 360° Rotation – AB or AB+XL Counterweight [All capacities are listed in kips (mt)]														
5° Offset					17.5° Offset					30° Offset				
Load Radius ft (m)	Jib Length ft (m)				Load Radius ft (m)	Jib Length ft (m)				Load Radius ft (m)	Jib Length ft (m)			
	20 (6.1)	30 (9.1)	40 (12.2)	50 (15.2)		20 (6.1)	30 (9.1)	40 (12.2)	50 (15.2)		20 (6.1)	30 (9.1)	40 (12.2)	50 (15.2)
19 (5.8)	20.0 (9.0)				19 (5.8)					19 (5.8)				
20 (6.1)	20.0 (9.0)				20 (6.1)					20 (6.1)				
25 (7.6)	20.0 (9.0)	20.0 (9.0)	20.0 (9.0)		25 (7.6)	20.0 (9.0)				25 (7.6)				
30 (9.1)	20.0 (9.0)	20.0 (9.0)	19.4 (8.8)	17.0 (7.7)	30 (9.1)	20.0 (9.0)	18.6 (8.4)			30 (9.1)	14.2 (6.4)			
35 (10.7)	19.3 (8.7)	19.5 (8.8)	17.2 (7.8)	15.8 (7.1)	35 (10.7)	19.6 (8.9)	17.0 (7.7)	14.8 (6.7)		35 (10.7)	13.2 (5.9)	10.9 (4.9)		
40 (12.2)	16.1 (7.3)	16.3 (7.4)	16.2 (7.3)	14.2 (6.4)	40 (12.2)	16.3 (7.4)	15.7 (7.1)	13.6 (6.1)	11.8 (5.3)	40 (12.2)	12.5 (5.6)	10.2 (4.6)	8.8 (4.0)	
50 (15.2)	11.7 (5.3)	11.9 (5.4)	12.0 (5.4)	11.7 (5.3)	50 (15.2)	11.9 (5.4)	12.2 (5.5)	11.6 (5.2)	10.1 (4.5)	50 (15.2)	11.2 (5.0)	9.1 (4.1)	7.7 (3.5)	6.8 (3.0)
60 (18.3)	8.9 (4.0)	9.1 (4.1)	9.2 (4.1)	9.3 (4.2)	60 (18.3)	9.1 (4.1)	9.3 (4.2)	9.5 (4.3)	8.8 (4.0)	60 (18.3)	9.2 (4.1)	8.3 (3.7)	7.0 (3.1)	6.0 (2.7)
70 (21.3)	7.0 (3.1)	7.2 (3.2)	7.3 (3.3)	7.4 (3.3)	70 (21.3)	7.1 (3.2)	7.4 (3.3)	7.5 (3.4)	7.7 (3.5)	70 (21.3)		7.5 (3.4)	6.4 (2.9)	5.5 (2.5)
80 (24.4)		5.8 (2.6)	5.9 (2.6)	6.0 (2.7)	80 (24.4)		5.9 (2.6)	6.1 (2.7)	6.2 (2.8)	80 (24.4)			5.9 (2.6)	5.0 (2.2)
90 (27.4)			4.8 (2.1)	4.9 (2.2)	90 (27.4)				5.1 (2.3)	90 (27.4)				4.7 (2.1)
100 (30.5)				4.1 (1.8)	100 (30.5)					100 (30.5)				

This material is supplied for reference use only. Operator must refer to in-cab Crane Rating Manual and Operator's Manual to determine allowable crane lifting capacities and assembly and operating procedures.



70 ft (21.3m) Main Boom Length – 360° Rotation – AB or AB+XL Counterweight [All capacities are listed in kips (mt)]														
5° Offset					17.5° Offset					30° Offset				
Load Radius ft (m)	Jib Length ft (m)				Load Radius ft (m)	Jib Length ft (m)				Load Radius ft (m)	Jib Length ft (m)			
	20 (6.1)	30 (9.1)	40 (12.2)	50 (15.2)		20 (6.1)	30 (9.1)	40 (12.2)	50 (15.2)		20 (6.1)	30 (9.1)	40 (12.2)	50 (15.2)
25 (7.6)	20.0 (9.0)	20.0 (9.0)			25 (7.6)	20.0 (9.0)				25 (7.6)				
30 (9.1)	20.0 (9.0)	20.0 (9.0)	19.3 (8.7)	16.8 (7.6)	30 (9.1)	20.0 (9.0)	18.2 (8.2)			30 (9.1)	14.5 (6.5)			
35 (10.7)	19.1 (8.6)	19.3 (8.7)	17.2 (7.8)	15.8 (7.1)	35 (10.7)	19.4 (8.8)	16.6 (7.5)	14.5 (6.5)		35 (10.7)	13.7 (6.2)	11.2 (5.0)		
40 (12.2)	15.9 (7.2)	16.1 (7.3)	16.2 (7.3)	14.2 (6.4)	40 (12.2)	16.2 (7.3)	16.1 (7.3)	13.3 (6.0)	11.5 (5.2)	40 (12.2)	12.9 (5.8)	10.5 (4.7)		
50 (15.2)	11.5 (5.2)	11.7 (5.3)	11.8 (5.3)	11.7 (5.3)	50 (15.2)	11.7 (5.3)	12.0 (5.4)	11.5 (5.2)	9.8 (4.4)	50 (15.2)	11.7 (5.3)	9.4 (4.2)	8.0 (3.6)	6.9 (3.1)
60 (18.3)	8.7 (3.9)	8.9 (4.0)	9.0 (4.0)	9.1 (4.1)	60 (18.3)	8.9 (4.0)	9.1 (4.1)	9.3 (4.2)	8.6 (3.9)	60 (18.3)	9.0 (4.0)	8.6 (3.9)	7.2 (3.2)	6.2 (2.8)
70 (21.3)	6.8 (3.0)	7.0 (3.1)	7.1 (3.2)	7.2 (3.2)	70 (21.3)	6.9 (3.1)	7.2 (3.2)	7.4 (3.3)	7.5 (3.4)	70 (21.3)		7.3 (3.3)	6.6 (3.0)	5.7 (2.5)
80 (24.4)	5.4 (2.4)	5.6 (2.5)	5.7 (2.5)	5.8 (2.6)	80 (24.4)		5.7 (2.5)	5.9 (2.6)	6.0 (2.7)	80 (24.4)			6.1 (2.7)	5.2 (2.3)
90 (27.4)		4.5 (2.0)	4.6 (2.0)	4.7 (2.1)	90 (27.4)			4.8 (2.1)	4.9 (2.2)	90 (27.4)				4.9 (2.2)
100 (30.5)			3.8 (1.7)	3.8 (1.7)	100 (30.5)				4.0 (1.8)	100 (30.5)				
110 (33.5)				3.1 (1.4)	110 (33.5)					110 (33.5)				

This material is supplied for reference use only. Operator must refer to in-cab Crane Rating Manual and Operator's Manual to determine allowable crane lifting capacities and assembly and operating procedures.



80 ft (24.4m) Main Boom Length – 360° Rotation – AB or AB+XL Counterweight [All capacities are listed in kips (mt)]														
5° Offset					17.5° Offset					30° Offset				
Load Radius ft (m)	Jib Length ft (m)				Load Radius ft (m)	Jib Length ft (m)				Load Radius ft (m)	Jib Length ft (m)			
	20 (6.1)	30 (9.1)	40 (12.2)	50 (15.2)		20 (6.1)	30 (9.1)	40 (12.2)	50 (15.2)		20 (6.1)	30 (9.1)	40 (12.2)	50 (15.2)
25 (7.6)	20.0 (9.0)	20.0 (9.0)			25 (7.6)					25 (7.6)				
30 (9.1)	20.0 (9.0)	20.0 (9.0)	19.3 (8.7)		30 (9.1)	20.0 (9.0)				30 (9.1)	14.9 (6.7)			
35 (10.7)	18.9 (8.5)	19.1 (8.6)	17.2 (7.8)	15.8 (7.1)	35 (10.7)	19.3 (8.7)	16.7 (7.5)			35 (10.7)	14.0 (6.3)			
40 (12.2)	15.6 (7.0)	15.8 (7.1)	16.0 (7.2)	14.2 (6.4)	40 (12.2)	16.0 (7.2)	16.0 (7.2)	13.2 (5.9)	11.3 (5.1)	40 (12.2)	13.3 (6.0)	10.8 (4.9)		
50 (15.2)	11.3 (5.1)	11.4 (5.1)	11.6 (5.2)	11.7 (5.3)	50 (15.2)	11.5 (5.2)	11.8 (5.3)	11.4 (5.1)	9.7 (4.4)	50 (15.2)	11.7 (5.3)	9.7 (4.4)	8.2 (3.7)	7.1 (3.2)
60 (18.3)	8.5 (3.8)	8.7 (3.9)	8.8 (4.0)	8.9 (4.0)	60 (18.3)	8.7 (3.9)	8.9 (4.0)	9.2 (4.1)	8.5 (3.8)	60 (18.3)	8.8 (4.0)	8.9 (4.0)	7.4 (3.3)	6.4 (2.9)
70 (21.3)	6.6 (3.0)	6.7 (3.0)	6.9 (3.1)	6.9 (3.1)	70 (21.3)	6.7 (3.0)	7.0 (3.1)	7.2 (3.2)	7.3 (3.3)	70 (21.3)	6.8 (3.0)	7.1 (3.2)	6.9 (3.1)	5.8 (2.6)
80 (24.4)	5.2 (2.3)	5.3 (2.4)	5.5 (2.5)	5.5 (2.5)	80 (24.4)	5.3 (2.4)	5.5 (2.5)	5.7 (2.5)	5.8 (2.6)	80 (24.4)		5.6 (2.5)	5.9 (2.6)	5.4 (2.4)
90 (27.4)	4.1 (1.8)	4.3 (1.9)	4.4 (2.0)	4.5 (2.0)	90 (27.4)		4.4 (2.0)	4.6 (2.0)	4.7 (2.1)	90 (27.4)			4.7 (2.1)	4.9 (2.2)
100 (30.5)		3.4 (1.5)	3.5 (1.5)	3.6 (1.6)	100 (30.5)			3.7 (1.6)	3.8 (1.7)	100 (30.5)				4.0 (1.8)
110 (33.5)			2.8 (1.2)	2.9 (1.3)	110 (33.5)				3.1 (1.4)	110 (33.5)				
120 (36.6)				2.3 (1.0)	120 (36.6)					120 (36.6)				

This material is supplied for reference use only. Operator must refer to in-cab Crane Rating Manual and Operator's Manual to determine allowable crane lifting capacities and assembly and operating procedures.



90 ft (27.4m) Main Boom Length – 360° Rotation – AB or AB+XL Counterweight [All capacities are listed in kips (mt)]														
5° Offset					17.5° Offset					30° Offset				
Load Radius ft (m)	Jib Length ft (m)				Load Radius ft (m)	Jib Length ft (m)				Load Radius ft (m)	Jib Length ft (m)			
	20 (6.1)	30 (9.1)	40 (12.2)	50 (15.2)		20 (6.1)	30 (9.1)	40 (12.2)	50 (15.2)		20 (6.1)	30 (9.1)	40 (12.2)	50 (15.2)
25 (7.6)	20.0 (9.0)				25 (7.6)					25 (7.6)				
30 (9.1)	20.0 (9.0)	20.0 (9.0)	19.3 (8.7)		30 (9.1)	20.0 (9.0)				30 (9.1)				
35 (10.7)	18.6 (8.4)	18.8 (8.5)	17.3 (7.8)	15.9 (7.2)	35 (10.7)	19.1 (8.6)	16.7 (7.5)			35 (10.7)	14.3 (6.4)			
40 (12.2)	15.4 (6.9)	15.6 (7.0)	15.8 (7.1)	14.3 (6.4)	40 (12.2)	15.8 (7.1)	15.9 (7.2)	13.1 (5.9)		40 (12.2)	13.6 (6.1)	11.0 (4.9)		
50 (15.2)	11.0 (4.9)	11.2 (5.0)	11.3 (5.1)	11.4 (5.1)	50 (15.2)	11.3 (5.1)	11.6 (5.2)	11.3 (5.1)	9.6 (4.3)	50 (15.2)	11.5 (5.2)	10.0 (4.5)	8.3 (3.7)	
60 (18.3)	8.3 (3.7)	8.4 (3.8)	8.6 (3.9)	8.6 (3.9)	60 (18.3)	8.5 (3.8)	8.7 (3.9)	9.0 (4.0)	8.5 (3.8)	60 (18.3)	8.6 (3.9)	9.0 (4.0)	7.6 (3.4)	6.5 (2.9)
70 (21.3)	6.4 (2.9)	6.5 (2.9)	6.6 (3.0)	6.7 (3.0)	70 (21.3)	6.5 (2.9)	6.8 (3.0)	7.0 (3.1)	7.1 (3.2)	70 (21.3)	6.6 (3.0)	7.0 (3.1)	7.1 (3.2)	6.0 (2.7)
80 (24.4)	5.0 (2.2)	5.1 (2.3)	5.2 (2.3)	5.3 (2.4)	80 (24.4)	5.1 (2.3)	5.3 (2.4)	5.5 (2.5)	5.6 (2.5)	80 (24.4)	5.2 (2.3)	5.5 (2.5)	5.7 (2.5)	5.6 (2.5)
90 (27.4)	3.9 (1.7)	4.0 (1.8)	4.1 (1.8)	4.2 (1.9)	90 (27.4)	4.0 (1.8)	4.2 (1.9)	4.3 (1.9)	4.5 (2.0)	90 (27.4)		4.3 (1.9)	4.5 (2.0)	4.7 (2.1)
100 (30.5)	3.0 (1.3)	3.2 (1.4)	3.3 (1.5)	3.4 (1.5)	100 (30.5)		3.3 (1.5)	3.5 (1.5)	3.6 (1.6)	100 (30.5)			3.6 (1.6)	3.8 (1.7)
110 (33.5)		2.5 (1.1)	2.6 (1.1)	2.7 (1.2)	110 (33.5)			2.7 (1.2)	2.8 (1.2)	110 (33.5)				3.0 (1.3)
120 (36.6)			2.0 (0.9)	2.1 (0.9)	120 (36.6)				2.2 (1.0)	120 (36.6)				
130 (39.6)				1.6 (0.7)	130 (39.6)					130 (39.6)				

This material is supplied for reference use only. Operator must refer to in-cab Crane Rating Manual and Operator's Manual to determine allowable crane lifting capacities and assembly and operating procedures.



100 ft (30.5m) Main Boom Length – 360° Rotation – AB or AB+XL Counterweight [All capacities are listed in kips (mt)]														
5° Offset					17.5° Offset					30° Offset				
Load Radius ft (m)	Jib Length ft (m)				Load Radius ft (m)	Jib Length ft (m)				Load Radius ft (m)	Jib Length ft (m)			
	20 (6.1)	30 (9.1)	40 (12.2)	50 (15.2)		20 (6.1)	30 (9.1)	40 (12.2)	50 (15.2)		20 (6.1)	30 (9.1)	40 (12.2)	50 (15.2)
30 (9.1)	20.0 (9.0)	20.0 (9.0)			30 (9.1)	20.0 (9.0)				30 (9.1)				
35 (10.7)	18.4 (8.3)	18.6 (8.4)	17.4 (7.9)	15.9 (7.2)	35 (10.7)	18.9 (8.5)	16.7 (7.5)			35 (10.7)	14.6 (6.6)			
40 (12.2)	15.2 (6.9)	15.4 (6.9)	15.6 (7.0)	14.4 (6.5)	40 (12.2)	15.6 (7.0)	15.9 (7.2)	13.0 (5.9)		40 (12.2)	13.9 (6.3)	11.2 (5.0)		
50 (15.2)	10.8 (4.9)	11.0 (4.9)	11.1 (5.0)	11.2 (5.0)	50 (15.2)	11.1 (5.0)	11.4 (5.1)	11.3 (5.1)	9.5 (4.3)	50 (15.2)	11.4 (5.1)	10.2 (4.6)	8.5 (3.8)	
60 (18.3)	8.0 (3.6)	8.2 (3.7)	8.3 (3.7)	8.4 (3.8)	60 (18.3)	8.3 (3.7)	8.5 (3.8)	8.8 (4.0)	8.4 (3.8)	60 (18.3)	8.5 (3.8)	8.8 (4.0)	7.8 (3.5)	6.6 (3.0)
70 (21.3)	6.1 (2.7)	6.3 (2.8)	6.4 (2.9)	6.5 (2.9)	70 (21.3)	6.3 (2.8)	6.5 (2.9)	6.8 (3.0)	6.9 (3.1)	70 (21.3)	6.4 (2.9)	6.8 (3.0)	7.1 (3.2)	6.1 (2.7)
80 (24.4)	4.7 (2.1)	4.9 (2.2)	5.0 (2.2)	5.1 (2.3)	80 (24.4)	4.9 (2.2)	5.1 (2.3)	5.3 (2.4)	5.4 (2.4)	80 (24.4)	5.0 (2.2)	5.3 (2.4)	5.5 (2.5)	5.7 (2.5)
90 (27.4)	3.6 (1.6)	3.8 (1.7)	3.9 (1.7)	4.0 (1.8)	90 (27.4)	3.8 (1.7)	4.0 (1.8)	4.1 (1.8)	4.3 (1.9)	90 (27.4)		4.1 (1.8)	4.3 (1.9)	4.6 (2.0)
100 (30.5)	2.8 (1.2)	2.9 (1.3)	3.0 (1.3)	3.1 (1.4)	100 (30.5)	2.9 (1.3)	3.1 (1.4)	3.2 (1.4)	3.4 (1.5)	100 (30.5)			3.4 (1.5)	3.6 (1.6)
110 (33.5)	2.1 (0.9)	2.2 (1.0)	2.4 (1.0)	2.4 (1.0)	110 (33.5)		2.3 (1.0)	2.5 (1.1)	2.6 (1.1)	110 (33.5)				2.8 (1.2)
120 (36.6)		1.7 (0.7)	1.8 (0.8)	1.9 (0.8)	120 (36.6)			1.9 (0.8)	2.0 (0.9)	120 (36.6)				
130 (39.6)			1.3 (0.5)	1.4 (0.6)	130 (39.6)				1.5 (0.6)	130 (39.6)				
140 (42.7)				1.0 (0.4)	140 (42.7)					140 (42.7)				

This material is supplied for reference use only. Operator must refer to in-cab Crane Rating Manual and Operator's Manual to determine allowable crane lifting capacities and assembly and operating procedures.



110 ft (33.5m) Main Boom Length – 360° Rotation – AB or AB+XL Counterweight [All capacities are listed in kips (mt)]														
5° Offset					17.5° Offset					30° Offset				
Load Radius ft (m)	Jib Length ft (m)				Load Radius ft (m)	Jib Length ft (m)				Load Radius ft (m)	Jib Length ft (m)			
	20 (6.1)	30 (9.1)	40 (12.2)	50 (15.2)		20 (6.1)	30 (9.1)	40 (12.2)	50 (15.2)		20 (6.1)	30 (9.1)	40 (12.2)	50 (15.2)
30 (9.1)	20.0 (9.0)				30 (9.1)					30 (9.1)				
35 (10.7)	18.2 (8.2)	18.4 (8.3)	17.4 (7.9)		35 (10.7)	18.7 (8.4)				35 (10.7)				
40 (12.2)	15.0 (6.8)	15.2 (6.9)	15.3 (6.9)	14.4 (6.5)	40 (12.2)	15.4 (6.9)	15.8 (7.1)			40 (12.2)	14.2 (6.4)			
50 (15.2)	10.6 (4.8)	10.8 (4.9)	10.9 (4.9)	11.0 (4.9)	50 (15.2)	10.9 (4.9)	11.2 (5.0)	11.2 (5.0)	9.5 (4.3)	50 (15.2)	11.2 (5.0)	10.4 (4.7)	8.6 (3.9)	
60 (18.3)	7.8 (3.5)	8.0 (3.6)	8.1 (3.6)	8.2 (3.7)	60 (18.3)	8.1 (3.6)	8.3 (3.7)	8.6 (3.9)	8.4 (3.8)	60 (18.3)	8.3 (3.7)	8.7 (3.9)	8.0 (3.6)	6.8 (3.0)
70 (21.3)	5.9 (2.6)	6.0 (2.7)	6.2 (2.8)	6.2 (2.8)	70 (21.3)	6.1 (2.7)	6.3 (2.8)	6.6 (3.0)	6.7 (3.0)	70 (21.3)	6.3 (2.8)	6.6 (3.0)	6.9 (3.1)	6.3 (2.8)
80 (24.4)	4.5 (2.0)	4.6 (2.0)	4.7 (2.1)	4.8 (2.1)	80 (24.4)	4.6 (2.0)	4.9 (2.2)	5.1 (2.3)	5.2 (2.3)	80 (24.4)	4.8 (2.1)	5.1 (2.3)	5.4 (2.4)	5.6 (2.5)
90 (27.4)	3.4 (1.5)	3.5 (1.5)	3.7 (1.6)	3.7 (1.6)	90 (27.4)	3.5 (1.5)	3.7 (1.6)	3.9 (1.7)	4.1 (1.8)	90 (27.4)	3.6 (1.6)	3.9 (1.7)	4.2 (1.9)	4.4 (2.0)
100 (30.5)	2.6 (1.1)	2.7 (1.2)	2.8 (1.2)	2.9 (1.3)	100 (30.5)	2.7 (1.2)	2.9 (1.3)	3.0 (1.3)	3.2 (1.4)	100 (30.5)		3.0 (1.3)	3.2 (1.4)	3.4 (1.5)
110 (33.5)	1.9 (0.8)	2.0 (0.9)	2.1 (0.9)	2.2 (1.0)	110 (33.5)	1.9 (0.8)	2.1 (0.9)	2.3 (1.0)	2.4 (1.0)	110 (33.5)			2.4 (1.0)	2.6 (1.1)
120 (36.6)	1.3 (0.5)	1.4 (0.6)	1.5 (0.6)	1.6 (0.7)	120 (36.6)		1.5 (0.6)	1.7 (0.7)	1.8 (0.8)	120 (36.6)				2.0 (0.9)
130 (39.6)		1.0 (0.4)	1.1 (0.5)	1.1 (0.5)	130 (39.6)				1.3 (0.5)	130 (39.6)				

This material is supplied for reference use only. Operator must refer to in-cab Crane Rating Manual and Operator's Manual to determine allowable crane lifting capacities and assembly and operating procedures.



5495 (supersedes 5462)–0906–N8

Link-Belt Construction Equipment Company Lexington, Kentucky www.linkbelt.com

®Link-Belt is a registered trademark. Copyright 2006. We are constantly improving our products and therefore reserve the right to change designs and specifications.