



Articulating Cranes

5200

Technical Specifications

Material Handling Systems





Specifications	1 Hydraulic	2 Hydraulic	2 Hydraulic 1 Manual
Crane Rating*	52,000 ft-lb (7.2 tm)	52,000 ft-lb (7.2 tm)	51,330 ft-lb (7.1 tm)
Horizontal Reach from centerline of rotation	20'1" (6.1 m)	26'4" (8.0 m)	32'2" (9.8 m)
Hydraulic Extension	70" (1.8 m)	70" x 2 (1.8 m x 2)	70" x 2 (1.8 m x 2)
Manual Extension	None	None	70"
Vertical Reach from mounting surface from ground/40" frame height	26'6" (8.1 m) 29'10" (9.1 m)	32'4" (9.8 m) 35'8" (10.9 m)	37'10" (11.5 m) 41'2" (12.5 m)
Crane Weight	2,820 lb (1279.2 kg)	3,060 lb (1388.0 kg)	3,140 lb (1424.3 kg)
Outrigger Span	12'4" (3.7 m)	12'4" (3.7 m)	12'4" (3.7 m)
Outrigger Pads	12" x 12" (30.5 cm x 30.5 cm)	12" x 12" (30.5 cm x 30.5 cm)	12" x 12" (30.5 cm x 30.5 cm)
Crane Storage Height from mounting surface from ground/40" frame height	7'0" (2.1 m) 10'4" (3.1 m)	7'0" (2.1 m) 10'4" (3.1 m)	7'0" (2.1 m) 10'4" (3.1 m)
Mounting Space Required**	28" (0.7 m)	28" (0.7 m)	28" (0.7 m)
Rotational Torque	7,800 ft-lb (1.1 tm)	7,800 ft-lb (1.1 tm)	7,800 ft-lb (1.1 tm)
Optimum Pump Capacity	9 U.S. gpm (34.1 L/min)	9 U.S. gpm (34.1 L/min)	9 U.S. gpm (34.1 L/min)
System Operating Pressure	2,500 psi (172.4 bar)	2,500 psi (172.4 bar)	2,500 psi (172.4 bar)
Oil Reservoir Capacity	17 U.S. gallons (64.4 L)	17 U.S. gallons (64.4 L)	17 U.S. gallons (64.4 L)
Hook Approach horizontal from centerline of rotation vertical from mounting surface	2'11" (0.9 m) 6'9" (2.1 m)	3'1" (0.9 m) 6'4" (1.9 m)	3'1" (0.9 m) 6'4" (1.9 m)

* Crane rating (ft-lb) is the rated load (lb) x the respective distance (ft) from centerline of rotation with all extensions retracted and the inner and outer booms in a horizontal position. This is the ANSI B30.22 standard.

** Allow an additional 5" between the cab and crane base for swing clearance.

Capacity Charts

2 Hydraulic/1 Manual Extension

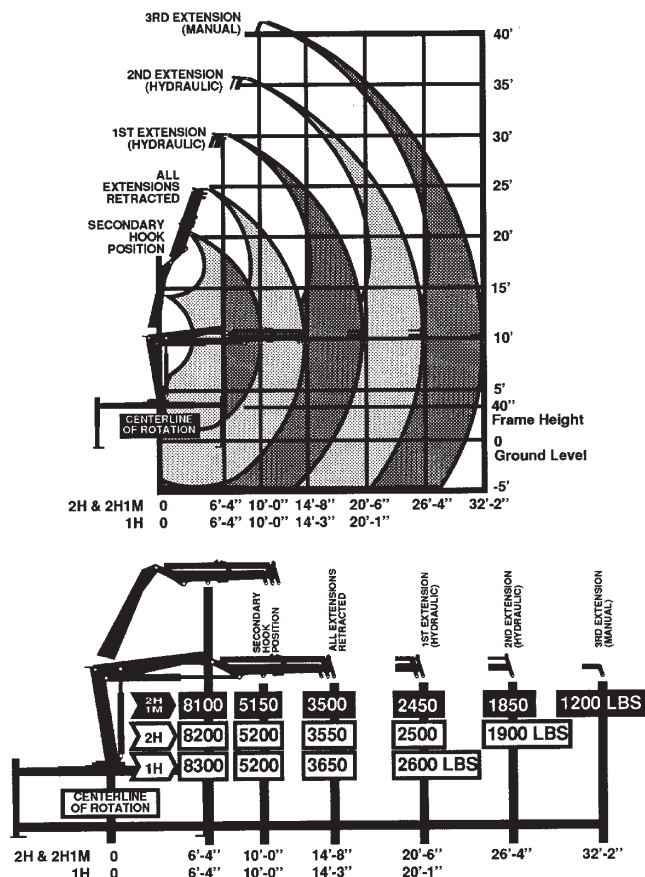

- Capacities (for above charts) through geometric range are limited to those shown in horizontal position.
- Loads shown are based on crane structural or hydraulic capability. Before lift is made, stability must be checked per SAE J765A.
- Working loads will be limited to those shown. Deduct the weight of load-handling devices.
- Winch-lifting capacity is limited to those shown. Maximum 4,000 lb for one-part line.



5200 Articulating Crane

Performance Characteristics

Rotation	450° (7.9 rad)	30 seconds
Inner Boom Elevation	-49° to +77° (-0.9 to +1.3 rad)	24 seconds
Outer Boom Articulation	139° (2.4 rad)	21 seconds
Telescopic Extensions	70"/70" (1.8 m/1.8 m)	26/15seconds
Single Stage Extension	70" (1.8 m)	15 seconds
Vertical Outrigger Stroke	24" (0.6 m)	6 seconds

Power Source

Integral mounted hydraulic pump and PTO application. Other standard power sources may be utilized. Minimum power required is 17 horsepower.

Cylinder Holding Valves

The holding sides of all standard cylinders are equipped with integral mounted holding or counterbalance valves to prevent sudden cylinder collapse in case of hose or other hydraulic failure. The outrigger cylinders have positive, pilot-operated holding valves that open only on command. The inner cylinders have single pilot-operated counterbalance valves while the outer and extension boom cylinders have double counterbalance valves. The counterbalance valve serves several functions. First, it is a holding valve. Second, it is so constructed that it will control the lowering function and allow that motion to be feathered while under load. Finally, if a hose breaks the only oil loss will be that in the hose.

Rotation System

Rotation of the crane is accomplished through a turntable bearing, powered by a high-torque hydraulic motor through a ring-and-pinion type spur gear train. Total gear reduction is 39.6 to 1.

Hydraulic System

The hydraulic system is an open-centered, full-pressure system, requiring 9 gpm optimum oil flow at 2,500 psi. Eight-spool, stack-type control valve, six of which are used for the standard crane and the remaining two which are plugged but easily adapted for additional optional features. Dual operational handles for six functions are located at both sides of crane for convenient operation. System includes hydraulic oil reservoir, suction-line strainer, pump, 8-section control valve, return-line filter and all hoses and fittings.

Minimum Chassis Specifications

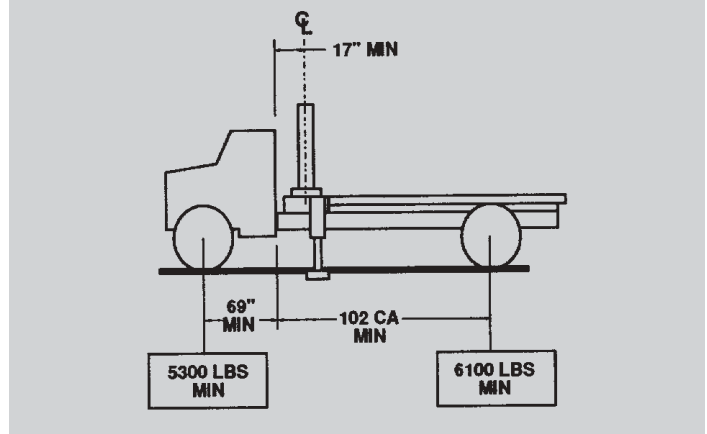

Crane Mount	Behind Cab
Crane Working Area	360°
Chassis Style	Conventional Cab
Front Axle Rating (GAWR)	7,000 lb
Rear Axle Rating (GAWR)	14,000 lb Single Axle
Wheelbase	171" (4.3 m)
Cab-To-Axle	102" (2.6 m)
Outrigger Width Required	12'4" (3.7 m)
Resistance To Bending Moment	720,000 in-lb
Frame Section Modulus	14.4 in ³
Frame Yield Strength	50,000 psi
Minimum Finished Unit Weight To Maintain Vehicle Stability	
Front Axle	5,300 lb*
Rear Axle	6,100 lb*
Total Finished Unit Weight	11,400 lb

* Allows lifting full-capacity load in a 360° arc when crane is installed immediately behind the cab. Great care should be taken when swinging the load from rear of vehicle to front of vehicle since the front axle springs will compress, thus affecting the levelness of the vehicle.

Notes

1. GAWR means Gross Axle Weight Rating and is dependent on all components of the vehicle such as axles, tires, wheels, springs, brakes, steering and frame strength meeting the manufacturer's recommendations. Always specify GAWR when purchasing a truck.
2. Minimum axle requirements may increase with use of diesel engines, longer wheelbase or service bodies. Contact the factory for further information.
3. Weight distribution calculations are required to determine final axle loading.
4. All chassis and crane combinations must be stability-tested to ensure stability per ANSI B30.22



5200 Articulating Crane

Geometric Configurations

1 Hydraulic Extension

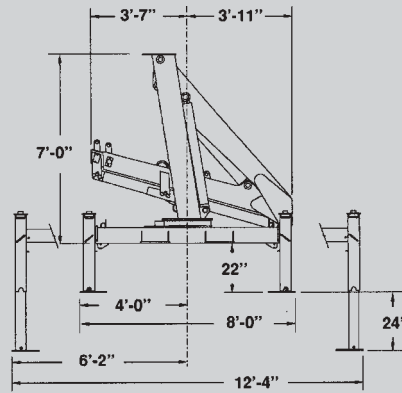
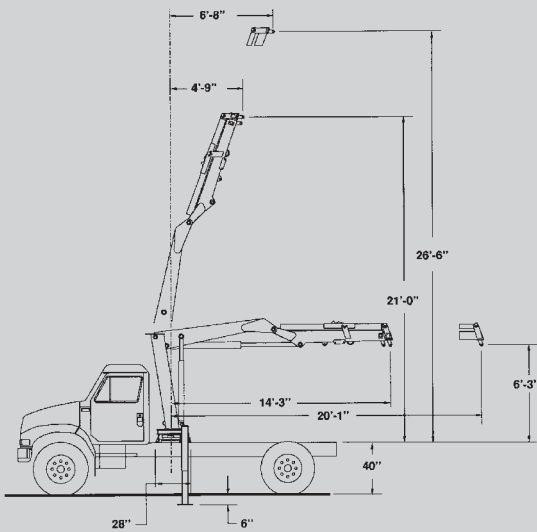

Hook Approach Dimensions

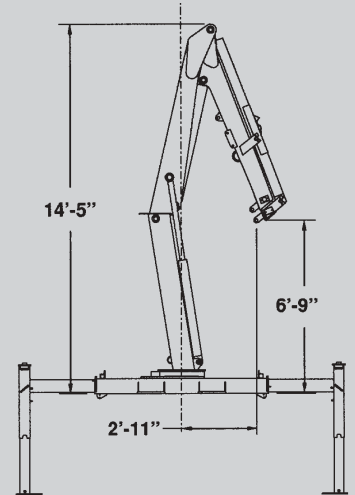

Stowed Position & Outrigger Dimensions

2 Hydraulic Extensions and 2 Hydraulic / 1 Manual Extension

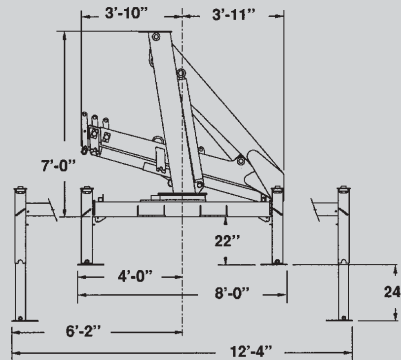
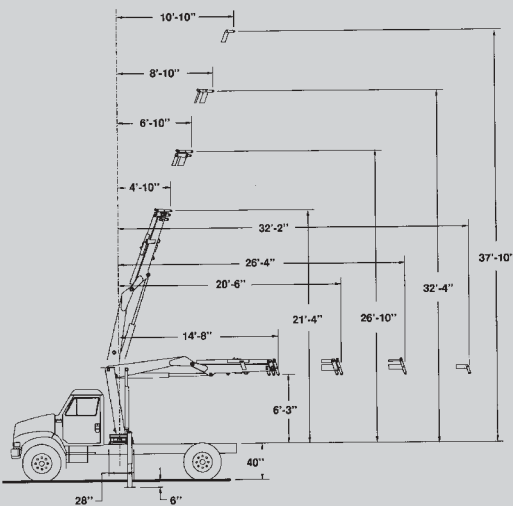

Hook Approach Dimensions

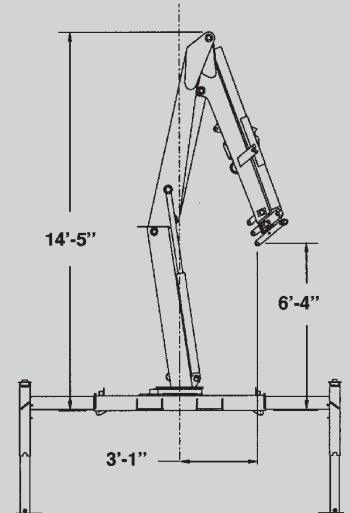

Stowed Position & Outrigger Dimensions



Iowa Mold Tooling Co., Inc.

500 Highway 18 West
 P.O. Box 189
 Garner, Iowa 50438-0189
 (641) 923-3711
 Fax: (641) 923-6063
 Web Site: www.imt.com

(800) 247-5958

IMT and the IMT LOGO are registered trademarks or trademarks of Iowa Mold Tooling Co., Inc.

Copyright © 2002 Iowa Mold Tooling Co., Inc.
 All Rights Reserved

PN 660218.06/02.1.5k

Manufacturer's Limited Warranty Coverage

Products manufactured by IMT are warranted to be free from defects in material and workmanship, under proper use, application and maintenance in accordance with IMT's written recommendations, instructions and specifications as follows:

1. One (1) year: labor on IMT workmanship.
2. One (1) year: original IMT parts.
3. Three (3) years: crane structural.

For policy details please refer to the IMT warranty policy.

IMT reserves the right to change specifications and design without notice.