



# LIBERATOR 3200

10,000 ft-lbs Crane Rating



Designed  
to a  
Higher Standard

## Better by design

ETI is committed to designing and manufacturing the best electric hydraulic crane value in the industry. Our cranes are innovatively designed to perform to a higher standard of durability and reliability, and to provide the maximum duty cycle possible in an electric crane. We've backed that commitment with our limited lifetime structural warranty and factory direct technical support. You can be assured that your new Liberator crane will provide many years of dependable service.

**ETI**  
A **PALFINGER** Company



Distributed by:

Equipment Technology LLC  
 341 NW 122nd  
 Oklahoma City, OK 73114  
 Toll-Free: 1-888-748-3841  
 Fax: 1-405-755-6829  
 www.eti1.com

L3200  
 11.11

**LIBERATOR 3200**

Liberator 3200 cranes come complete with 25' power cable, a crane grounding cable, a 225 amp fuse, a 4' frame grounding cable, 25' remote control pendant, mounting bolts and owner's manual.

All Liberator 3200 cranes are shipped assembled, factory tested and ready to go to work.

1000 amp CCA battery and 100 amp alternator recommended.  
 8,000 GVW chassis recommended minimum.

**Maximum lifting capabilities**

3200 lbs	3'
2500 lbs	4'
2000 lbs	5'
1666 lbs	6'
1428 lbs	7'
1250 lbs	8'
1000 lbs	10'
909 lbs	11'
769 lbs	13'
666 lbs	15'

**Features**

- Self-contained 12 Volt DC hydraulic system supplies 2.2 gallons per min, powered by high-output extended on time series wound motor.
- Automatic overload protection prevents hoist up, boom extension and boom down.
- Anti two-block system is standard with power extensions.
- Large diameter, self-locking, all steel worm gear rotation drive mounted on steel slewing ring crane bearing and provides 360 degree continuous power rotation.
- Load cushioning counterbalance/check valves on all cylinders for precise load holding and handling.
- Safety valves on all cylinders prevents load drop if hose fails.
- 100% Solid-state control system has arc-suppression circuitry for extended life of switches, contactors and motors.
- Hydraulic boom elevation from -5° to 75°.
- 25' remote control pendant with "Quik-Turn" connector.
- Planetary gear hoist is designed for maximum power, efficiency and hook speed.
- Industrial grade electrical contactors, no automotive type solenoids.
- 80' of 1/4" wire rope. Hoist drum and wire rope are on the outside of the boom where they are visible to the operator.
- Permanently lubricated polymer wire rope pulleys reduce wire rope wear.
- Boom extensions slide on low friction self-lubricating polymer slide pads.
- Meets OSHA 1910.180 requirements, and ANSI B30.5 safety standards .
- Powder coat finish for high gloss and durability.
- Mounting bolts and nuts provided (4 ea. 3/4" gr 8).

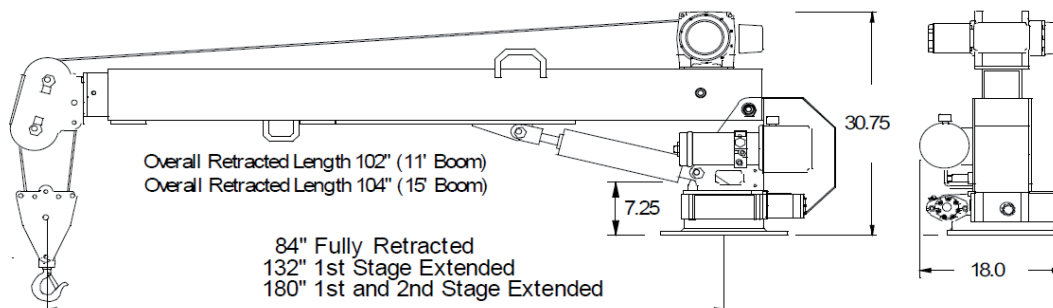

Model	Power Boom	Power Extend	Manual Extend	Weight	O.A. Length Retracted	O.A. Width
LIB 3200 XTW-PR	Yes	No	7' to 11'	580 lbs	8' - 6"	18"
LIB 3200 XTW15-PR	Yes	No	7' to 11'	617 lbs	8' - 8"	18"
LIB 3200 PXTW-PR	Yes	7' to 11'	No	660 lbs	8' - 6"	18"
LIB 3200 PXTW15-PR	Yes	7' to 11'	11' to 15'	697 lbs	8' - 8"	18"

