

90-XC

HYDROCRANE®

90 TON HYDRAULIC TRUCK CRANE

PRELIMINARY SPECIFICATIONS

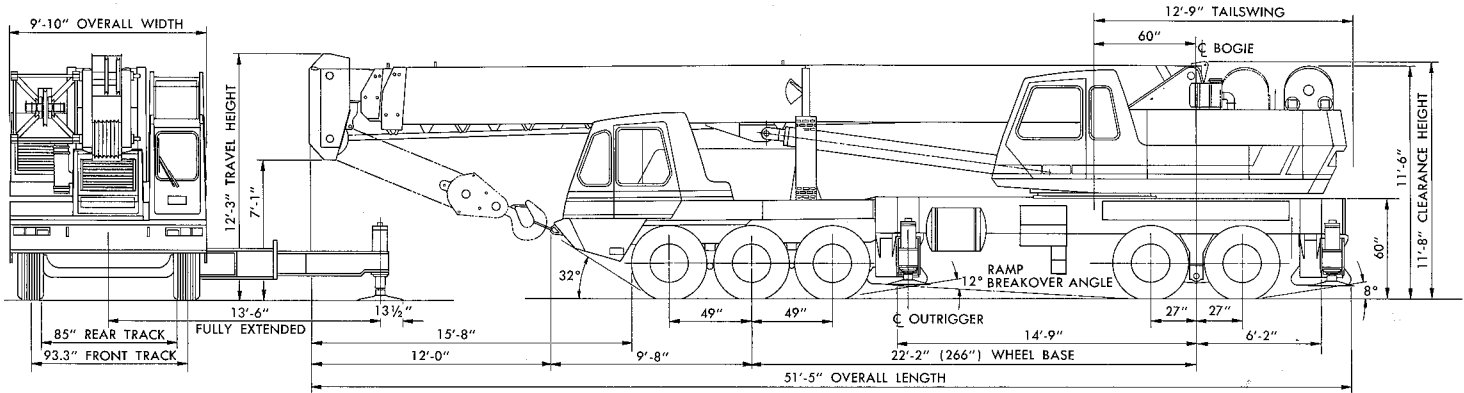

883259

HOIST DRUMS													
Hoist Unit	Lagging	Layer Of Rope	Pitch Diameter (Inches)	Normal Range				High Range				Rope Capacity	
				Low Line Pull		High Line Pull		Low Line Pull		High Line Pull			
				Max. Line Pull (Lbs.)	Max. Line Speed (FPM)	Max. Line Pull (Lbs.)	Max. Line Speed (FPM)	Max. Line Pull (Lbs.)	Max. Line Speed (FPM)	Max. Line Pull (Lbs.)	Max. Line Speed (FPM)	With Controlled Free Fall (Feet)	Without Controlled Free Fall (Feet)
Main or Auxiliary* B-E Model 20 3/4" Rope	Standard	1st	16.75	15,800	195	19,200	95	7,900	390	9,600	185	127	153
		2nd	18.25	14,500	210	17,700	100	7,200	425	8,800	205	265	320
		3rd	19.75	13,400	230	16,300	110	6,700	460	8,100	220	415	501
		4th	21.25	12,400	245	15,200	120	6,200	495	7,600	235	576	695
Model 20 3/4" Rope	High Speed	1st	23.50	11,200	275	13,700	130	5,600	550	6,800	260	186	224
		2nd	25.00	10,600	290	12,900	140	5,300	585	6,400	280	376	453
Auxiliary B-E Model 10 5/8" Rope	Standard	1st	11.25	7,800	395	9,500	190	—	—	—	—	74	93
		2nd	12.50	7,000	435	8,600	210	—	—	—	—	157	196
		3rd	13.75	6,400	480	7,800	230	—	—	—	—	248	309
		4th	15.00	5,900	525	7,100	250	—	—	—	—	347	433
	High Speed	1st	17.44	5,000	610	6,100	290	—	—	—	—	115	144
		2nd	18.69	4,700	650	5,700	315	—	—	—	—	238	298

*Only normal range available on model 20 auxiliary hoist unit.

ENGINE SPECIFICATIONS — UPPER							
Make	Model	Type	Cylinders	Bore x Stroke (Inches)	Displacement (Cubic Inches)	Horsepower (S. A. E. Gross)	Max. Altitude (Feet)
Detroit Diesel	6V53N	Diesel	6	3 7/8 x 4 1/2	318	197 at 2800 RPM	4,000
Cummins	V-504C	Diesel	8	4 3/4 x 3 3/4	504	185 at 2800 RPM	4,000

90-XC HYDROCRANE® 90 TON HYDRAULIC TRUCK CRANE

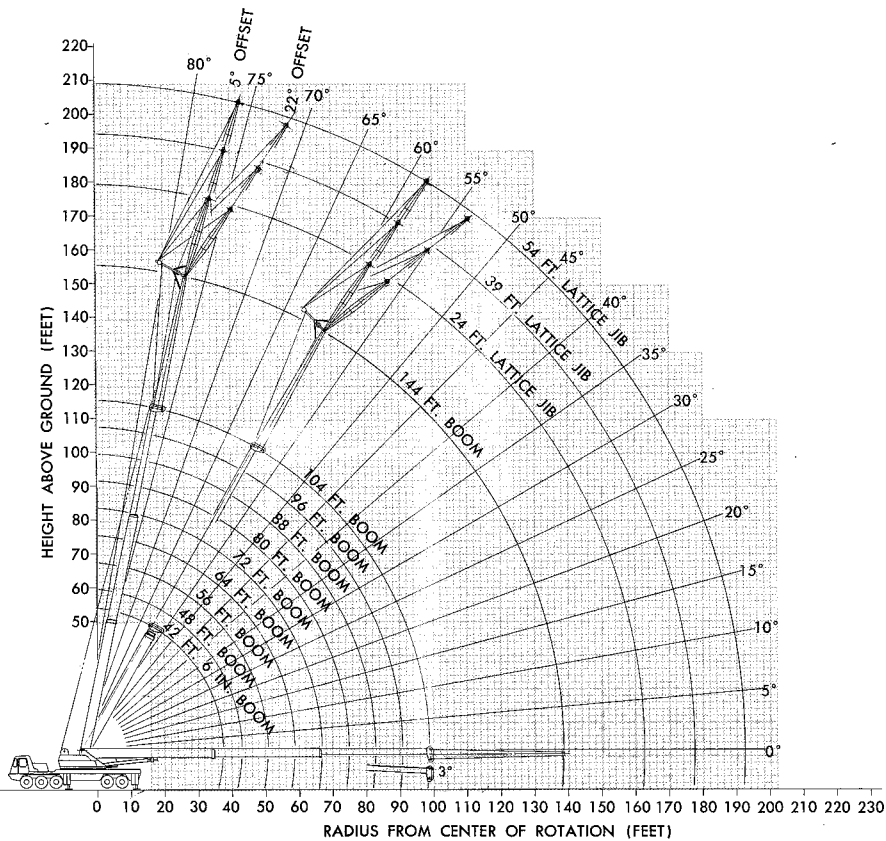

HOOK BLOCKS			
Capacity	No. Sheaves	No. Parts Line	'Y' Dim.
90 Ton	6	1-12	72 In.
20 Ton	1	1-3	65 In.
8.5 Ton	—	1	45 In.

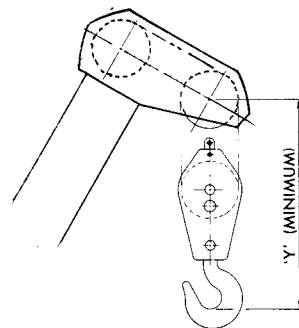

887049

MAXIMUM ALLOWABLE LOADS — JIB SERVICE WITH COUNTERWEIGHT						
WEIGHT OF HOOKS, HOOK BLOCKS, SLINGS, AND ALL OTHER LOAD HANDLING DEVICES, EXCEPT THE HOIST ROPE, SHALL BE CONSIDERED PART OF THE LOAD.						
OUTRIGGERS SET* — LOAD IN POUNDS						
Jib Length In Feet						
Boom Angle In Degrees	24		39		54	
	5° Offset **	22° Offset **	5° Offset **	22° Offset **	5° Offset **	22° Offset **
80	20,000	15,000	15,000	10,000	10,000	7,500
75	14,500	12,400	12,250	8,300	8,000	6,700
70	11,750	10,500	10,250	7,200	6,800	5,900
65	10,000	9,000	8,750	6,200	5,800	5,100
60	8,500	7,750	7,350	5,300	5,000	4,400
55	7,000	6,500	6,300	4,500	4,150	3,700
50	6,000	5,500	5,300	3,800	3,400	3,100
45	5,100	4,900	4,400	3,100	2,800	2,550
40	4,000	3,900	3,500	2,550	2,300	2,100
35	3,150	3,000	2,800	2,150	1,900	1,750
30	2,500	2,400	2,050	1,800	1,650	1,600

746580

*See "OUTRIGGERS SET" note, page 6.

**"Offset" — Angular offset centerline of boom to centerline of jib.

Maximum Allowable Loads shown in shaded area are limited by factors other than tipping.

CAUTION: DO NOT OPERATE MACHINE WITH JIB ON BOOM POINT UNLESS THE MACHINE IS LEVELED AND STANDING ON A FIRM, UNIFORM SUPPORTING SURFACE WITH THE "OUTRIGGERS SET".

CAUTION: LONG CANTILEVER BOOMS CAN CREATE A TIPPING CONDITION WHEN IN EXTENDED AND LOWERED POSITION. DO NOT OPERATE AT BOOM ANGLES LOWER THAN SHOWN ON CHART.

JIB SERVICE

Maximum Allowable Loads shown apply only to machine with all components in first class condition built or recommended by Bucyrus-Erie Company.

Maximum Allowable Loads are based on freely suspended loads with the machine leveled and standing on a firm, uniform supporting surface. Practical working loads depend on supporting ground, the effect of shock or side loading, wind, and other factors affecting stability, hazardous surroundings, experience of personnel and proper handling, all of which must be taken into account by the operator.

Maximum Allowable Loads are based on components and conditions shown under "LIMITATIONS" and "MACHINE EQUIPMENT".

Maximum Allowable Loads are in accordance with P.C.S.A. Standard #2.

LOAD RATING DEDUCT DATA

Weight of hooks, hook blocks, slings, and all other load handling devices, except the hoist rope, shall be considered part of the load.

When hook block is suspended on boom point sheave, the load over the jib point sheave must be reduced as follows:

24 ft. Jib	1100 lbs.
39 ft. Jib	1000 lbs.
54 ft. Jib	950 lbs.

When hook block is suspended on swing-around point sheave, the load over the jib point sheave must be reduced as follows:

24 ft. Jib	1550 lbs.
39 ft. Jib	1400 lbs.
54 ft. Jib	1300 lbs.

LIMITATIONS

Required length of boom for lattice jib service is 144 feet. The boom must be fully extended, with swing-around section locked into working position on the boom point sheave pins.

Refer to "Crane Load Rating Chart" for other items that apply.

MACHINE EQUIPMENT

Alloy steel tubular jib, 11,000 lb. counterweight, and pertinent equipment listed on "Boom Load Rating Chart".

90-XC HYDROCRANE®

90 TON HYDRAULIC TRUCK CRANE

UPPER WORKS

Revolving Frame:

All welded, reinforced alloy steel plate construction with all primary structural members boxed, for maximum rigidity.

Engine:

Diesel engine with 12 volt electric starting system and alternator. Fuel tank capacity 50 gallons.

Hydraulic Pumps:

Two multi stage, gear type, tandem mounted, direct driven. Total flow, 212 GPM at 2500 RPM pump speed. Master clutch standard.

Hydraulic Valves:

Pressure compensating for winch and swing functions and low effort for boom functions.

Hydraulic Reservoir:

Open type, with integral baffles and return line diffuser. System capacity 260 gallons.

Filter System:

Return line type with replaceable 10 micron elements and filter condition indicator.

Swing:

Hydraulic vane type motor driving a precision double reduction planetary swing unit with integral disc brake. Brake is spring set with hydraulic release. Hydraulic disc type glide brake and mechanical type houselock optional. Maximum swing speed is 3 RPM.

Chassis:

Specially designed and built to Bucyrus-Erie Company specifications. Equipment includes front and rear fenders, top frame decking, towing eyes at front, steps, and grab handles. A 75 gallon fuel tank is mounted on side of the frame. Standard carrier has 266 in. wheelbase and 9 ft. 10 in. overall width.

Outriggers:

Hydraulically powered, double box type welded to frame, front and rear. Two stage telescoping beams extend to 27 ft. 0 in. centerline to centerline of vertical jacks and retract to 9 ft. 10 in. overall width. High strength alloy steel is used throughout. Vertical cylinders are equipped with double lock valves designed to prevent drift either up or down. Alloy steel floats.

Outrigger controls located on both sides of carrier frame near rear outriggers are standard. Bixial levels located at outrigger controls.

Axles:

Front Axles: Schuler DCB Tridem, non-driving type. 93.3 in. track Dynamic capacity of Tridem is 60,000 pounds.

Rear Axles: Eaton DP580-P Tandem. Dynamic capacity of tandem, 58,000 pounds. 85 inch track. 7.39 ratio standard.

Suspension:

Front: Reyco — spring mounted.
Rear: Tandem walking beams.

Wheels:

Steel spoke type.

Swing Circle:

Precision ball bearing swing circle, designed and built by Bucyrus-Erie Company.

Counterweight:

Optional 11,000 lb. removable cast.

Boom:

42 ft. 6 in. to 104 ft. long, three sections full power with synchronized, dual lever, extension and retraction. 40 ft. horizontal swing-around lattice extension for total boom length of 144 ft. Lattice jibs 24, 39, and 54 ft. optional. Integral holding valves on both telescoping cylinders. Boom extend time is 70 seconds (minimum) and boom retract time is 91 seconds (minimum). Boom length decals are standard.

Boom Elevation:

Twin double acting hydraulic cylinders with integral holding valves. Elevation from minus 3 degrees to 80 degrees. Combination control lever provides for hand or foot operation. Boom elevation times are 71 seconds (minimum) raising and 65 seconds (minimum) lowering. Boom angle indicator is standard.

Operator's Compartment:

Independent of machinery cab with windows on four sides and overhead for full visibility. Constructed of Tri-Armor for strength and

sound insulation. Sliding door window and hinged front window panel. With front and glareproof overhead panels hinged open, the operator has unrestricted visibility. Operator's controls include hand and foot throttle with full length control levers. Bucket seat, windshield wiper, horn, and door and window locks are standard. Heater, defroster, and air conditioner are optional.

Main Hoist Drum:

Precision, high speed, planetary hoist units are custom designed and built by Bucyrus-Erie Company. Hydraulic motor driven with power up and down. Integral automatic brake is designed to prevent load creep. Two speed control is standard on main drum, normal and high range. Controlled free fall optional, allows high speed lowering under full control of foot pedal operated mechanical brake.

High speed lagging optional. Lagging fits over reeved drum. Line required for operation is unspooled from top layers of drum. Lagging installed, then respool. Unused line is stored under high speed lagging.

Auxiliary Hoist Drum:

A second hoist drum that mounts ahead of main drum is optional. It is a Bucyrus-Erie Company designed and built unit and includes same features as main drum. Controlled free fall and high speed lagging are available as options.

CARRIER

Tires:

Front: (Six) 16.5 x 22.5 — 16 ply, highway tread standard.

Rear: (Eight) 12 x 20 — 16 ply non-directional tread standard.

Brakes:

Service Brakes: Air brakes on three front and both rear axles.

Front: 17¼ in. x 4 in.

Rear: 16½ in. x 7 in.

Parking Brakes: Maxi spring loaded brake chambers on both rear axles with reserve (emergency release) air tank.

Steering:

Hydraulic power assist type is standard.

Power Plant:

Detroit Diesel 8V-71N diesel engine, 8 cylinder, 568 cu. in. displacement is standard. 12 volt electric starting system. Cummins NTCC 350 is optional.

Clutch:

15½ in. diameter, two plate.

Transmission:

Fuller RT01258LL with 10 speeds forward. Roadranger type with single shift lever.

Ratios:

Forward	
1st — 13.15:1	6th — 2.49:1
2nd — 9.21:1	7th — 1.83:1
3rd — 6.15:1	8th — 1.34:1
4th — 4.51:1	9th — 1.00:1
5th — 3.36:1	10th — .74:1

Reverse

1st — 13.75:1

2nd — 9.63:1

3rd — 2.86:1

Cab:

One-man type semi-low profile, Tri-Armor cab offset to left side of carrier. West Coast type mirrors. Bostrom Viking T-bar seat is standard.

Instruments:

Speedometer, voltmeter, tachometer, oil pressure indicator, fuel gauge, water temperature indicator, air pressure gauge, and low air pressure warning device.

Accessories:

Standard equipment includes: sealed beam headlights, tail and stop lights, dome light, front and rear directional signals, clearance lights and reflectors, electric horn, windshield washer and wiper, and heater and defroster. Optional equipment includes: Spare tire and rim, air horn, hourmeter, low oil pressure warning device, back-up alarm, Jacobs engine brake and air conditioning.

Geared Speed:

With standard engine at governed speed (MPH): Maximum 47

Miscellaneous:

GVW Rating (pounds)	112,000
Turning Radius	50 ft.
Clearance Radius	55 ft.



90-XC HYDRAU 90 TON HYDRAU

PCSA CLA

MAXIMUM ALLOWABLE LOADS — CRANE									
WEIGHT OF HOOKS, HOOK BLOCKS, SLINGS, ETC., EXCEPT THE HOIST ROPE, SHALL BE									
BOOM LENGTH									
Load Radius In Feet	42.5			56			72		
	Boom Angle In Degrees	Boom Point Pin Height (Ft.—In.)	Out-riggers Set* Load In Pounds	Boom Angle In Degrees	Boom Point Pin Height (Ft.—In.)	Out-riggers Set* Load In Pounds	Boom Angle In Degrees	Boom Point Pin Height (Ft.—In.)	Out-riggers Set* Load In Pounds
10	74.3	50-11	180,000						
12	71.4	50-1	164,300	76.0	64-5	143,000			
15	66.9	48-10	138,400	72.8	63-5	130,000	76.8	80-3	99,300
20	59.0	45-7	105,600	67.2	61-3	105,600	72.6	78-7	82,700
25	50.2	41-5	83,200	61.4	58-5	84,300	68.3	76-7	72,400
30	39.9	35-6	58,400	55.1	54-11	59,400	63.8	74-1	60,000
35	25.6	26-2	43,900	48.3	50-5	44,900	59.2	71-0	45,400
40				40.5	44-8	35,400	54.3	67-5	35,900
50				15.9	22-11	23,700	43.2	57-9	24,300
60							28.7	42-6	17,300

CRANE SERVICE

Maximum Allowable Loads shown apply only to machines with all components in first class condition built or recommended by Bucyrus-Erie Company.

Maximum Allowable Loads are based on freely suspended loads with the machine leveled and standing on a firm, uniform supporting surface. Practical working loads depend on supporting ground, the effect of shock or side loading, wind, and other factors affecting stability, hazardous surroundings, experience of personnel and proper handling, all of which must be taken into account by the operator.

Maximum Allowable Loads are based on components and conditions shown under "LIMITATIONS" and "MACHINE EQUIPMENT".

Maximum Allowable Loads are in accordance with P.C.S.A. Standard #2.

Load Radius is the horizontal distance from the axis of rotation before loading, to the center of the vertical hoist line or tackle with load applied.

LOAD RATING DEDUCT DATA

Weight of hooks, hook blocks, slings, jibs, and all other load handling devices, except the hoist rope, shall be considered part of the load.

Maximum Allowable Loads on main boom sheaves must be reduced 2,650 lbs. when lifting over the main boom with manual swing-around extension attached to boom point; Jibs — Maximum Allowable Loads must be reduced as follows:

Jib	When Lifting Over Main Boom With Swing-Around and Jib Attached	When Lifting Over Swing-Around With Jib Attached
24 Foot	4,500 lbs.	3,250 lbs.
39 Foot	4,950 lbs.	3,550 lbs.
54 Foot	5,400 lbs.	3,900 lbs.

LIMITATIONS

Main and Aux. Hoist Unit (Model #20): Hoist Tackle

For Loads Over (lbs.)	15,000	30,000	45,000	60,000	75,000	90,000
Parts of Line	2	3	4	5	6	7
	105,000	120,000	135,000	150,000	165,000	
	8	9	10	11	12	

Auxiliary Hoist Unit (Model #10): Hoist Tackle

For Loads Over (lbs.)	7,500	15,000	22,500	30,000	37,500	45,000
Parts of Line	2	3	4	5	6	7
		52,500	60,000	67,500	75,000	82,500
		8	9	10	11	12

Swing-Around Hoist Tackle

For loads over 15,000 pounds use 2 parts of line.

Jib Load Rating

For Maximum Allowable Loads on jibs, refer to separate Jib Load Rating Chart.

Boom Telescope

Maximum Allowable Load which may be telescoped is limited by boom angle, hydraulic pressure, and boom lubrication. Boom sections must be extended equally at all times.

Machine Weight

Maximum Allowable Load ratings are based on a machine having a minimum front axle loading of 43,000 lbs. and a minimum rear axle of 61,500 lbs. with the boom in the boom rack, and counterweight attached to upper works.

MACHINE EQUIPMENT

11,000 lbs. removable counterweight.

Carrier

266 in. W.B.—9 ft. 10 in. wide 10 x 4 semi-low profile cab carrier with hydraulic outriggers to 27 ft. 0 in. spread.

Wire Rope

Main and Auxiliary Hoist (Model #20) 3/4" dia., 6 x 25, IPS, IWRC, 51,200 lbs. minimum breaking strength.

Auxiliary Hoist (Model #10) 5/8" dia., 8 x 19, EIPS, IWRC, 36,200 lbs. minimum breaking strength.

For complete wire rope specifications and reeving, refer to instruction manual for this machine.



PROCRANE[®] HYDRAULIC TRUCK CRANE

CLASS 10-354

NE SERVICE* — WITH COUNTERWEIGHT

JIBS AND ALL OTHER LOAD HANDLING DEVICES,
CONSIDERED PART OF THE LOAD.

WIDTH IN FEET

88			104			144			
Boom Angle In Degrees	Boom Point Pin Height (Ft.—In.)	Out-riggers Set* Load In Pounds	Boom Angle In Degrees	Boom Point Pin Height (Ft.—In.)	Out-riggers Set* Load In Pounds	Boom Angle In Degrees	Boom Point Pin Height (Ft.—In.)	Out-riggers Set* Load In Pounds	Load Radius In Feet
									10
									12
									15
75.9	95-5	69,500							20
72.4	93-10	58,100	75.2	110-8	49,700				25
68.9	91-10	49,000	72.3	109-0	41,900	76.4	150-8	29,750	30
65.3	89-6	42,500	69.4	107-1	36,000	74.3	149-4	25,800	35
61.6	86-9	36,200	66.4	104-10	31,500	72.2	147-10	22,800	40
53.7	79-10	24,500	60.1	99-5	24,400	68.4	144-2	18,700	50
44.8	70-7	17,600	53.9	92-4	17,700	64.0	139-7	15,050	60
34.1	57-5	13,000	46.6	83-3	13,100	59.5	134-0	12,700	70
19.8	34-8	9,700	38.1	71-3	9,900	54.7	127-4	10,650	80
			27.3	53-10	7,400	49.6	119-5	8,700	90
						44.2	109-9	7,050	100
						38.1	99-0	5,500	110
						31.0	84-3	4,200	120
						21.9	63-10	3,150	130

835315

QUADRANT DIAGRAM
MACHINE — "OUTRIGGERS SET"

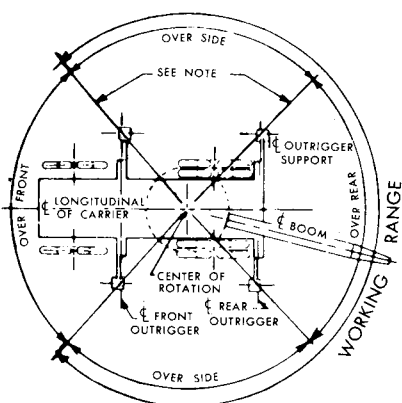

NOTE: THESE LINES DETERMINE THE LIMITING POSITION OF ANY LOAD FOR OPERATION WITHIN WORKING AREAS INDICATED.

"OUTRIGGERS SET"

See quadrant diagram "OUTRIGGERS SET". These are the Maximum Allowable Loads which can be lifted, Over the Side or Over the Rear. This machine must always be operated with the outriggers fully extended and set to a distance of 27 feet 0 inches between centerlines of the float connections with all tires clear of the ground.

DO NOT lift or swing loads within the quadrant designated Over Front.

Maximum Allowable Loads shown in shaded area are limited by factors other than tipping.

Crane Loads do not exceed 85% of the tipping loads with the machine leveled and standing on a firm, uniform supporting surface.

CAUTION: DO NOT LIFT LOADS, EXTEND BOOM, OR SWING MACHINE WITHOUT OUTRIGGERS FULLY SET.*

CAUTION: LONG CANTILEVER BOOMS CAN CREATE A TIPPING CONDITION WHEN IN EXTENDED AND LOWERED POSITION. WHERE NO LOAD IS SHOWN ON THE LOAD RATING CHART AT A GIVEN RADIUS, TIPPING CONDITION SHALL BE ASSUMED TO EXIST.

CAUTION: USE OF JIB IS LIMITED TO MACHINES WITH COUNTERWEIGHT PROPERLY ATTACHED TO REAR OF CRANE.



90-XC HY 90 TON HYDRAU PCSA CLA

MAXIMUM ALLOWABLE LOADS — CRANE									
WEIGHT OF HOOKS, HOOK BLOCKS, SLINGS EXCEPT THE HOIST ROPE, SHALL BE									
BOOM LENGTH									
Load Radius In Feet	42.5			56			72		
	Boom Angle In Degrees	Boom Point Pin Height (Ft.—In.)	Out- riggers Set* Load In Pounds	Boom Angle In Degrees	Boom Point Pin Height (Ft.—In.)	Out- riggers Set* Load In Pounds	Boom Angle In Degrees	Boom Point Pin Height (Ft.—In.)	Out- riggers Set* Load In Pounds
10	74.3	50-11	180,000						
12	71.4	50-1	161,800	76.0	64-5	143,000			
15	66.9	48-10	132,600	72.8	63-5	130,000	76.8	80-3	99,300
20	59.0	45-7	101,000	67.2	61-3	101,000	72.6	78-7	82,700
25	50.2	41-5	67,400	61.4	58-5	68,500	68.3	76-7	69,200
30	39.9	35-6	46,800	55.1	54-11	47,800	63.8	74-1	48,300
35	25.6	26-2	34,700	48.3	50-5	35,700	59.2	71-0	36,200
40				40.5	44-8	27,800	54.3	67-5	28,300
50				15.9	22-11	18,100	43.2	57-9	18,600
60							28.7	42-6	12,800

CRANE SERVICE

Maximum Allowable Loads shown apply only to machines with all components in first class condition built or recommended by Bucyrus-Erie Company.

Maximum Allowable Loads are based on freely suspended loads with the machine leveled and standing on a firm, uniform supporting surface. Practical working loads depend on supporting ground, the effect of shock or side loading, wind, and other factors affecting stability, hazardous surroundings, experience of personnel and proper handling, all of which must be taken into account by the operator.

Maximum Allowable Loads are based on components and conditions shown under "LIMITATIONS" and "MACHINE EQUIPMENT".

Maximum Allowable Loads are in accordance with P.C.S.A. Standard #2.

Load Radius is the horizontal distance from the axis of rotation before loading, to the center of the vertical hoist line or tackle with load applied.

LOAD RATING DEDUCT DATA

Weight of hooks, hook blocks, slings and all other load handling devices, except the hoist rope, shall be considered part of the load.

Maximum Allowable Loads on main boom sheaves must be reduced 2,650 lbs. when lifting over main boom with manual swing-around extension attached to boom point.

LIMITATIONS

Main and Aux. Hoist Unit (Model #20): Hoist Tackle

For Loads Over (lbs.)	15,000	30,000	45,000	60,000	75,000	90,000
Parts of Line	2	3	4	5	6	7
	105,000	120,000	135,000	150,000	165,000	
	8	9	10	11	12	

Auxiliary Hoist Unit (Model #10): Hoist Tackle

For Loads Over (lbs.)	7,500	15,000	22,500	30,000	37,500	45,000
Parts of Line	2	3	4	5	6	7
		52,500	60,000	67,500	75,000	82,500
		8	9	10	11	12

Swing-Around Hoist Tackle

For loads over 15,000 pounds use 2 parts of line.

Boom Telescope

Maximum Allowable Load which may be telescoped is limited by boom angle, hydraulic pressure, and boom lubrication. Boom sections must be extended equally at all times.

Machine Weight

Maximum Allowable Load ratings are based on a machine having a minimum front axle loading of 46,600 lbs. and a minimum rear axle of 46,900 lbs. with the boom in the rack.

MACHINE EQUIPMENT

No Counterweight.

Carrier

266 in. W.B. — 9 ft. 10 in. wide 10 x 4 semi-low profile cab carrier with hydraulic outriggers to 27 ft. 0 in. spread.

Wire Rope

Main and Auxiliary Hoist (Model #20) 3/4" dia., 6 x 25, IPS, IWRC, 51,200 lbs. minimum breaking strength.

Auxiliary Hoist (Model #10) 5/8" dia., 8 x 19, EIPS, IWRC, 36,200 lbs. minimum breaking strength.

For complete wire rope specifications and reeving, refer to instruction manual for this machine.

DROCRANE[®] HYDRAULIC TRUCK CRANE

SS 10-278

SERVICE* — WITHOUT COUNTERWEIGHT

AND ALL OTHER LOAD HANDLING DEVICES,
CONSIDERED PART OF THE LOAD.

TH IN FEET

88			104			144			Load Radius In Feet
Boom Angle In Degrees	Boom Point Pin Height (Ft.—In.)	Out-riggers Set* Load In Pounds	Boom Angle In Degrees	Boom Point Pin Height (Ft.—In.)	Out-riggers Set* Load In Pounds	Boom Angle In Degrees	Boom Point Pin Height (Ft.—In.)	Out-riggers Set* Load In Pounds	
75.9	95-5	69,500							20
72.4	93-10	58,100	75.2	110-8	49,700				25
68.9	91-10	48,000	72.3	109-0	41,900	76.4	150-8	29,750	30
65.3	89-6	36,500	69.4	107-1	36,000	74.3	149-4	25,800	35
61.6	86-9	28,600	66.4	104-10	28,700	72.2	147-10	22,800	40
53.7	79-10	18,900	60.1	99-5	19,000	68.4	144-2	18,700	50
44.8	70-7	13,100	53.9	92-4	13,200	64.0	139-7	15,050	60
34.1	57-5	9,300	46.6	83-3	9,400	59.5	134-0	11,100	70
19.8	34-8	6,500	38.1	71-3	6,600	54.7	127-4	8,300	80
			27.3	53-10	4,500	49.6	119-5	6,200	90
						44.2	109-9	4,500	100
						38.1	99-0	3,200	110
						31.0	84-3	2,100	120
						21.9	63-10	1,200	130

833720

"OUTRIGGERS SET"

See quadrant diagram "OUTRIGGERS SET". These are the Maximum Allowable Loads which can be lifted, Over the Side or Over the Rear. This machine must always be operated with the outriggers fully extended and set to a distance of 27 feet 0 inches between centerlines of the float connections with all tires clear of the ground.

DO NOT lift or swing loads within the quadrant designated Over Front.

Maximum Allowable Loads shown in shaded area are limited by factors other than tipping.

Crane Loads do not exceed 85% of the tipping loads with the machine leveled and standing on a firm, uniform supporting surface.

CAUTION: DO NOT LIFT LOADS, EXTEND BOOM, OR SWING MACHINE WITHOUT OUTRIGGERS FULLY SET.*

CAUTION: LONG CANTILEVER BOOMS CAN CREATE A TIPPING CONDITION WHEN IN EXTENDED AND LOWERED POSITION. WHERE NO LOAD IS SHOWN ON THE LOAD RATING CHART AT A GIVEN RADIUS, TIPPING CONDITION SHALL BE ASSUMED TO EXIST.

WARNING: The information contained in this specification is to be used only as a guide in evaluating the performance of a machine. For operation of a machine always refer to the capacity plate on the machine (since this specification may apply to a different model or series).

QUADRANT DIAGRAM
MACHINE — "OUTRIGGERS SET"

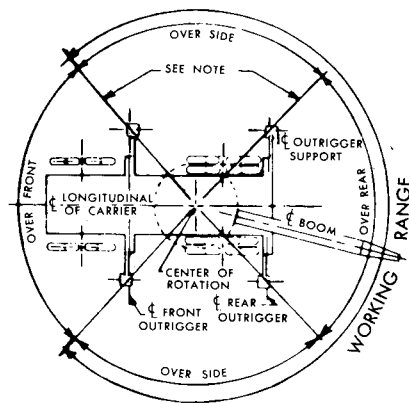

NOTE: THESE LINES DETERMINE THE LIMITING POSITION OF ANY LOAD FOR OPERATION WITHIN WORKING AREAS INDICATED.



90-XC HYDROCRANE®

90 TON HYDRAULIC TRUCK CRANE

AXLE LOADS IN POUNDS

266 INCH WHEELBASE CARRIER				TOTAL
1	Basic Machine (Including diesel engines in upper and carrier, full fuel, outriggers, 104-ft. boom plus 40-ft. swing-away section and main hoist.) Note: Does not include operator or counterweight.	46,600	46,900	93,500
*	2 Add Free Fall Main Hoist Unit	— 75	+ 375	300
*	3 Add Model 10 Auxiliary Hoist Unit W/Rope	— 150	+ 1,600	1,450
4	Add Free Fall Auxiliary Hoist Unit Model 20	— 30	+ 330	300
5	Add Model 20 Auxiliary Hoist Unit W/Rope	— 350	+ 3,750	3,400
6	Add Free Fall Auxiliary Hoist Unit Model 10	— 25	+ 240	215
*	7 Add 330 Pound Ball to Front Bumper	+ 480	— 150	330
8	Add 90 Ton Hook Block to Front Bumper	+ 2,585	— 785	1,800
9	Add 24 Foot Lattice Jib and Mast and Storage Rack	+ 1,450	— 0	1,450
10	Remove Swing Section	— 2,205	+ 20	— 2,185
11	11,000 Pound Counterweight Stored on Carrier*	+ 8,375	+ 2,625	11,000

*Recommend counterweight be stored on carrier for travel to obtain optimum weight distribution.



BUCYRUS-ERIE COMPANY

General Offices: South Milwaukee, Wisconsin, U. S. A. 53172

It is the policy of Bucyrus-Erie Company to improve its products continually. The right is reserved to make changes in specifications or design which in the opinion of this Company are in accord with this policy, or which are necessitated by the unavailability of materials. The description herein is for the purpose of identifying the type of machine, and does not limit or extend the express warranty provisions in any contract of sale.

